

STUDY MATERIAL

JEE

FOR MAIN & ADVANCED

CHEMISTRY

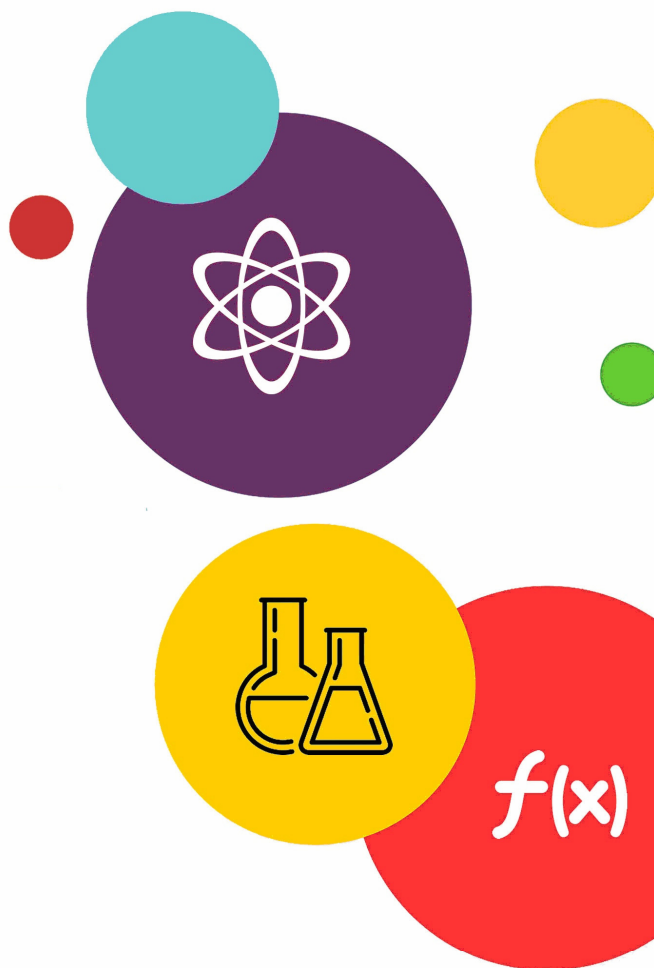

 CP PUBLICATION

CHEMISTRY

Study Material for JEE Main & Advanced preparation
Prepared by Career Point Kota Experts



CAREER POINT

CONTENTS OF THE PACKAGE AT A GLANCE

CHEMISTRY

Class 11

Physical Chemistry (I)

- ◆ Atomic Structure
- ◆ Basic Concepts of Chemistry
- ◆ Redox & Volumetric Analysis
- ◆ Gaseous State
- ◆ Chemical Energetics
- ◆ Chemical Equilibrium
- ◆ Acid Base & Ionic Equilibrium

Inorganic Chemistry (I)

- ◆ Periodic Table
- ◆ Chemical Bonding
- ◆ Hydrogen Family
- ◆ s-block elements

Organic Chemistry (I)

- ◆ Classification & Nomenclature
- ◆ Isomerism
- ◆ General Organic Chemistry
- ◆ Hydrocarbons
- ◆ Aromatic Chemistry
- ◆ Environmental Chemistry

Class 12

Physical Chemistry (II)

- ◆ Chemical Kinetics
- ◆ Electro Chemistry
- ◆ Solid State
- ◆ Solutions
- ◆ Surface Chemistry

Organic Chemistry (II)

[A]

- ◆ Halogen Derivatives
- ◆ Alcohol, Ether & Phenol
- ◆ Carbonyl Compounds

[B]

- ◆ Carboxylic Acid & Its Derivatives
- ◆ Nitrogen Compounds, Amines
- ◆ Carbohydrates, Amino Acid, Protein & Polymers
- ◆ Practical Organic Chemistry
- ◆ Chemistry in Everyday life

Inorganic Chemistry (II)

- ◆ p-block Elements
- ◆ Salt Analysis
- ◆ Transitional Elements
- ◆ Metallurgy
- ◆ Co-Ordination Compound

Note to the Students

Career Point offers this must have Study Package in Physics to meet the complete curriculum needs of engineering aspirants. The set comprises of 6 books: **Chemistry** - set of 3 books for class 11 and set of 3 books for Class 12. The set caters to the different requirements of students in classes XI and XII. It offers complete and systematic coverage of **JEE Main** and **JEE Advanced** syllabi and aims to provide firm foundation in learning and develop competitive edge in preparation of the JEE and other engineering entrance examinations.

COMPONENTS OF EACH CHAPTER

These books are designed with an engaging and preparation-focused pedagogy and offer a perfect balance of conceptual learning and problem solving skills.

Theory & Concepts

Each chapter consists of high quality theory that covers all the topics, sub-topics and concepts of JEE syllabus.

Atomic Structure

1. INTRODUCTION

- (a) The word atom was first introduced by Ostwald (1803 - 1807) in scientific world.
- (b) According to him matter is ultimately made up of extremely small indivisible particles called atoms.
- (c) It takes part in chemical reactions.
- (d) Atom is neither created nor destroyed

2. DALTON'S ATOMIC THEORY

Dalton proposed the atomic theory on the basis of the law of conservation of mass and law of definite proportions. He also proposed the law of multiple proportion as a logical consequence of this theory. The salient features of this theory are-

- (a) Each element is composed by extremely small particles called atoms.
- (b) Atoms of a particular element are all alike but differ with the atoms of other elements.
- (c) Atom of each element is an ultimate particle, and has a characteristic mass but is structureless.
- (d) Atom is indestructible i.e. it can neither be destroyed nor created by simple chemical reactions.
- (e) Atom of an element takes part in chemical reaction to form molecule.
- (f) In a given compound, the relative number and kind of atom are same.
- (g) Atoms of different elements combine in fixed ratio of small whole numbers to form compound atoms (now called molecules).

◆ Merits and Demerits of Dalton's theory :

A. Merits :

- (a) Dalton's theory explains the law of conservation of mass and some other laws of chemical combination.
- (b) Atoms of elements take part in chemical reaction is true till today.

B. Demerits :

- (a) There is no mention of atomic weights of elements.
- (b) He could not explain that why do atoms of same element combined with each other.
- (c) The law of definite proportion fails if different isotopes are used.

3. EARLIER EFFORTS TO REVEAL STRUCTURE OF ATOM

◆ Evidence for the Electrical nature of matter :

- (a) In 1833 Michael Faraday gave the first important clue about the electrical nature of atoms
- (b) He observed that when electricity is passed through an electrolyte (in the molten state or dissolved state), it undergoes chemical changes.
- (c) This phenomenon is called electrolysis
- (d) Later on in 1874, Stoney pointed out that like matter, electricity is composed of small discrete units of electricity. He proposed the name electron for these discrete units of electricity

◆ Cathode Rays - discovery of electron :

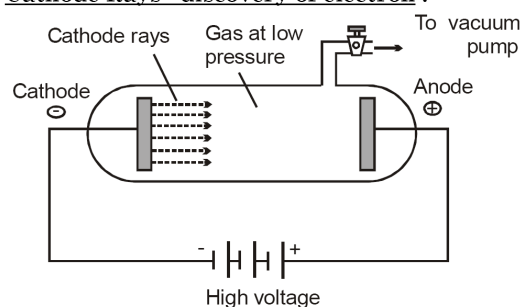

- (a) The electron was discovered as a result of the studies of the passage of electricity through gases at extremely low pressures known as discharge tube experiments.
- (b) In 1859, Julius Plucker started the study of conduction of electricity through gases at low pressure (10^{-4} atm.) in a discharge tube.
- (c) When a high voltage of the order of 10,000 volts or more was impressed across the electrodes, some sort of invisible rays moved from the negative electrode to the positive electrodes these rays are called as cathode rays
- (d) Further investigations were made by W. Crookes, J. Perrin, J.J. Thomson and others.
- (e) Cathode rays have the following properties.
 - (i) Path of travelling is straight from the cathode with a very high velocity. As it produces shadow of an object placed in its path

Important Points

This part contains important concepts & formulas of chapter at one place in short manner, So that student can revise all these in short time.



Points to Remember

1. The wave character is of no significance in case of large objects like cricket ball, a car, a train etc.
2. The most important applications of de-Broglie concept is in the construction of electron microscope and the study of surface structure of solids by electron diffraction.
3. Smaller the wavelength of the electron wave, more is the resolving power of the electron microscope
4. Uncertainty in measurement is not due to lack of any experimental technique but due to nature of subatomic particle itself
5. Shapes of orbitals are functional representation of mathematical solutions of Schrodinger equations. They do not represent any picture of electric charge or matter.

Solved Examples (JEE Main/Advanced)

To understand the application of concepts, there is a solved example section. It contains large variety of all types of solved examples with explanation to ensure understanding the application of concepts.

SOLVED EXAMPLES

Ex.1 The ratio of the wave lengths of last lines of Balmer and Lyman series is -
(A) 4 : 1 (B) 27 : 5
(C) 3 : 1 (D) 9 : 4

Sol.(A) The wave length of a spectral line may be given by the following expression

$$\frac{1}{\lambda} = R \left(\frac{1}{n_1^2} - \frac{1}{n_2^2} \right)$$

For Lyman series $n_1 = 1$, For Balmer series $n_1 = 2$

For the last line in both the series $n_2 = \infty$

For Lyman series

$$\frac{1}{\lambda_L} = R \left(1 - \frac{1}{\infty} \right) = R(1 - 0) = R$$

$$\lambda_L = \frac{1}{R}$$

For Balmer series

$$\frac{1}{\lambda_B} = R \left(\frac{1}{4} - \frac{1}{\infty} \right) = \frac{R}{4}$$

$$\lambda_B = \frac{4}{R}$$

$$\frac{\lambda_B}{\lambda_L} = \frac{4}{R} \times \frac{R}{1} = \frac{4}{1}$$

- (A) 96 Arbitrary units
(B) 192 Arbitrary units
(C) 288 Arbitrary units
(D) 384 Arbitrary units

Sol.(A) The energy of first Bohr's orbit of H-atom

$$= -\frac{2\pi^2 me^4}{h^2} = -864$$

The energy of third Bohr's orbit of H atom

$$= -\frac{2\pi^2 me^4}{h^2} \times \frac{1}{3^2} = -864 \times \frac{1}{9}$$

= -96 Arbitrary units

Energy required to separate the electron

$$= E_\infty - E_n$$

$$= 0 - (-96)$$

$$= 96 \text{ Arbitrary units}$$

Ex.4 In an electronic transition, the wavelength of a spectral line is inversely related to -

- (A) The nuclear charge of the atom
(B) The difference in energy levels
(C) The velocity of electron
(D) The number of orbitals involved in transition

Sol.(A)
$$\frac{1}{\lambda} = \frac{2\pi^2 me^4 Z^2}{ch^3 (4\pi\epsilon_0)^2} = \left[\frac{1}{n_1^2} - \frac{1}{n_2^2} \right]$$

Practice Exercises

Exercise Level - 1 : It contains objective questions with single correct choice to ensure sufficient practice to accurately apply formulae and concepts.

Exercise Level - 2 : It contains single objective type questions with moderate difficulty level to enhance the conceptual and application level of the student.

Exercise Level - 3 : It contains previous years question of JEE Main from Year 2005 to 2024.

EXERCISE (Level-3)

Old Examination Questions [JEE Main]

- Q.1** In a multi-electron atom, which of the following orbitals described by the three quantum numbers will have the same energy in the absence of magnetic and electric fields? [AIEEE- 2005]
(a) $n = 1, \ell = 0, m = 0$ (b) $n = 2, \ell = 0, m = 0$
(c) $n = 2, \ell = 1, m = 1$ (d) $n = 3, \ell = 2, m = 1$
(e) $n = 3, \ell = 2, m = 0$
(A) (b) and (c) (B) (a) and (b)
(C) (d) and (e) (D) (c) and (d)
- Q.2** Of the following sets which one does NOT contain isoelectronic species? [AIEEE- 2005]
(A) CN^- , N_2 , C_2^{2-}
(B) PO_4^{3-} , SO_4^{2-} , ClO_4^-
(C) BO_3^{3-} , CO_3^{2-} , NO_3^-
(D) SO_3^{2-} , CO_3^{2-} , NO_3^-
- Q.3** According to Bohr's theory, the angular momentum of an electron in 5th orbit is - [AIEEE 2006]
(A) $1.0 h/\pi$ (B) $10 h/\pi$
(C) $2.5 h/\pi$ (D) $25 h/\pi$
- Q.4** Uncertainty in the position of an electron (mass = 9.1×10^{-31} kg) moving with a velocity 300 m/s, accurate upto 0.001 %, will be ($h = 6.63 \times 10^{-34}$ Js) [AIEEE 2006]
(A) 5.76×10^{-2} m (B) 1.92×10^{-2} m
(C) 3.84×10^{-2} m (D) 19.2×10^{-2} m
- Q.5** Which of the following sets of quantum numbers represents the highest energy of an atom? [AIEEE 2007]
(A) $n = 3, \ell = 1, m = 1, s = +\frac{1}{2}$
(B) $n = 3, \ell = 2, m = 1, s = +\frac{1}{2}$
(C) $n = 4, \ell = 0, m = 0, s = +\frac{1}{2}$
(D) $n = 3, \ell = 0, m = 0, s = +\frac{1}{2}$
- Q.6** The ionization enthalpy of hydrogen atom is 1.312×10^6 J mol⁻¹. The energy required to excite the electron in the atom from $n = 1$ to $n = 2$ is [AIEEE 2008]
(A) 6.56×10^5 J mol⁻¹
(B) 7.56×10^5 J mol⁻¹
(C) 9.84×10^5 J mol⁻¹
(D) 8.51×10^5 J mol⁻¹
- Q.7** In an atom, an electron is moving with a speed of 600 m/s with an accuracy of 0.005%. Certainty with which the position of the electron can be located is ($h = 6.6 \times 10^{-34}$ kg m²s⁻¹, mass of electron, $m_e = 9.1 \times 10^{-31}$ kg) [AIEEE 2009]
(A) 1.52×10^{-4} m (B) 5.10×10^{-3} m
(C) 1.92×10^{-3} m (D) 3.84×10^{-3} m
- Q.8** Calculate the wavelength (in nanometer) associated with a proton moving at 1.0×10^8 m s⁻¹ (Mass of proton = 1.67×10^{-27} kg and $h = 6.63 \times 10^{-34}$ Js) - [AIEEE 2009]
(A) 0.032 nm (B) 0.40 nm
(C) 2.5 nm (D) 14.0 nm
- Q.9** A gas absorbs a photon of 355 nm and emits at two wavelengths. If one of the emissions is at 680 nm, the other is at : [AIEEE 2011]
(A) 1035 nm (B) 325 nm
(C) 743 nm (D) 518 nm
- Q.10** The frequency of light emitted for the transition $n = 4$ to $n = 2$ of He⁺ is equal to the transition in H atom corresponding to which of the following? [AIEEE 2011]
(A) $n = 2$ to $n = 1$ (B) $n = 3$ to $n = 2$
(C) $n = 4$ to $n = 3$ (D) $n = 3$ to $n = 1$
- Q.11** The electrons identified by quantum numbers n and ℓ [AIEEE-2012]
(a) $n = 4, \ell = 1$ (b) $n = 4, \ell = 0$
(c) $n = 3, \ell = 2$ (d) $n = 3, \ell = 1$
can be placed in order of increasing energy as -
(A) (d) < (b) < (c) < (a) (B) (b) < (d) < (a) < (c)
(C) (a) < (c) < (b) < (d) (D) (c) < (d) < (b) < (a)
- Q.12** The following sets of quantum numbers represents four electrons in an atom :
(i) $n = 4, \ell = 1$ (ii) $n = 4, \ell = 0$
(iii) $n = 3, \ell = 2$ (vi) $n = 3, \ell = 1$
The sequence representing increasing order of energy, is : [AIEEE Online-2012]
(A) (i) < (iii) < (ii) < (iv) (B) (ii) < (iv) < (i) < (iii)
(C) (iv) < (ii) < (iii) < (i) (D) (iii) < (i) < (iv) < (ii)
- Q.13** The limiting line in Balmer series will have a frequency of : [AIEEE Online-2012]
(Rydberg constant, $R_\infty = 3.29 \times 10^{15}$ cycles/s)
(A) 3.65×10^{14} s⁻¹ (B) 8.22×10^{14} s⁻¹
(C) 3.29×10^{15} s⁻¹ (D) 5.26×10^{13} s⁻¹
- Q.14** If the kinetic energy of an electron is increased four times, the wavelength of the de-Broglie wave associated with it would become : [AIEEE Online-2012]
(A) Two times (B) Half
(C) One fourth (D) Four times
- Q.15** Which pair of elements with the given atomic numbers is expected to have similar properties? [AIEEE Online-2012]
(A) 11, 12 (B) 40, 72
(C) 20, 36 (D) 10, 28

Exercise Level - 4 : It contains all variety of questions as per level of JEE Advanced such as MCQ, Column match, Passage based & Numerical type etc.

EXERCISE (Level-4)

Part-A : Multiple correct answer type questions

Q.1 Which of the following properties is/are proportional to the energy of the electromagnetic radiation ?

- (A) Frequency (B) Wave number
(C) Wavelength (D) Number of photons

Q.2 Which of the following statements are incorrect?

- (A) There are five unpaired electrons in (n-1)d suborbit in Fe³⁺
(B) Fe³⁺, Mn²⁺ and Cr all having 24 electrons will have same value of magnetic moment
(C) Copper (I) chloride is coloured salt
(D) Every coloured ion is paramagnetic

Q.3 Which is not the correct orbital notation if the wave function is –

$$\psi = \frac{1}{81\sqrt{6\pi}} \left(\frac{1}{a_0}\right)^{3/2} \sigma^2 e^{-\sigma r/a_0} (3\cos^2\theta - 1);$$

Here $\sigma = r/a_0$ and $a_0 = \frac{h^2 \epsilon_0}{\pi m e^2}$

- (A) 4s (B) 2P_x (C) 3P_y (D) 3d_{z²}

Q.4 Which of the following orbitals have no spherical nodes ?

- (A) 1s (B) 2s
(C) 2p (D) 3p

Q.5 In which of the following sets of orbitals, electrons have equal orbital angular momentum ?

- (A) 1s and 2s (B) 2s and 2p
(C) 2p and 3p (D) 3p and 3d

Q.6 Which of the following sets of quantum number are correct ?

(A) $n = 3, \ell = 2, m = +1, s = +\frac{1}{2}$

(B) $n = 3, \ell = 3, m = +3, s = +\frac{1}{2}$

(C) $n = 4, \ell = 0, m = 0, s = -\frac{1}{2}$

(D) $n = 5, \ell = 2, m = +4, s = -\frac{1}{2}$

Q.7 Rutherford's experiment established that :

- (A) Inside the atom there is a heavy positive centre
(B) Nucleus contains protons and neutrons
(C) Most of the space in the atoms is empty
(D) Size of the nucleus is very small

Q.8 Which of the following statements are incorrect ?

- (A) For designating orbitals three quantum numbers are needed
(B) The second ionization energy of helium is 4 times, the first ionization of hydrogen
(C) The third ionization energy of lithium is 9 times, the first ionization of hydrogen
(D) Radius of third orbit of Li²⁺ is 3 times the radius of third orbit of hydrogen atom

Q.9 Which of the following statements (regarding an atom of H) are correct ?

- (A) Kinetic energy of the electron is maximum in the first orbit
(B) Potential energy of the electron is maximum in the first orbit
(C) Radius of the second orbit is four times the radius of the first orbit
(D) Various energy levels are equally spaced

Q.10 Which of the following transition in H-atom would result in emission of radiations of same frequency ?

- (A) 4s → 3p (B) 4d → 3p
(C) 5s → 4s (D) 3s → 2p

Q.11 The radial distribution functions [P(r)] is used to determine the most probable radius, which is used to find the electron in a given orbital

$$\frac{dP(r)}{dr} \text{ for } 1s\text{-orbital of hydrogen like atom}$$

having atomic number Z, is

$$\frac{dP}{dr} = \frac{4Z^3}{a_0^3} \left(2r - \frac{2Zr^2}{a_0} \right) e^{-2Zr/a_0}$$

Then which of the following statements is/are correct ?

- (A) At the point of maximum value of radial distribution function $\frac{dP(r)}{dr} = 0$; One antinode is present

(B) Most probable radius of Li²⁺ is $\frac{a_0}{3}$ pm

(C) Most probable radius of He⁺ is $\frac{a_0}{2}$ pm

(D) Most probable radius of hydrogen atom is a_0 pm

Exercise Level - 5 : It contains previous years question of JEE Advanced from Year 2005 to 2024.

EXERCISE (Level-5)

Old Examination Questions [JEE Advanced]

Q.1 The number of radial nodal surface in 3s and 2p
[IIT-2005]
(A) 2, 0 (B) 2, 1 (C) 1, 0 (D) 0, 2

Q.2 Give answer : [IIT-2005]
(a) For first orbit of hydrogen atom, calculate the velocity of electron ($r = a_0 = 0.529 \text{ \AA}$)
(b) Calculate the de-broglie wavelength of electron in first Bohr orbit
(c) Calculate the orbital angular momentum of 2p orbital in terms of $h/2\pi$ units

Q.3 According to Bohr's theory, [IIT-2006]
 E_n = Total energy ;
 K_n = Kinetic energy
 V_n = Potential energy
 r_n = Radius of n^{th} orbit
Match the following :

Column-I		Column-II	
(A)	$V_n/K_n = ?$	(P)	0
(B)	If radius of n^{th} orbital is r_n , $r_n \propto E_n^x$, $x = ?$	(Q)	-1
(C)	Angular momentum in lowest orbital	(R)	-2
(D)	$\frac{1}{r^n} \propto Z^y$, $y = ?$	(S)	1

Q.4 Match the entries in column-I with the correctly related quantum no. (s) in column-II [IIT-2008]

Column-I		Column-II	
(A)	orbital angular momentum of the electron in a hydrogen like atomic orbital	(P)	Principal quantum number
(B)	A hydrogen like one electron wave function obeying Pauli's number principle	(Q)	Azimuthal quantum number
(C)	Shape, size and orientation of hydrogen like atomic orbital	(R)	magnetic quantum number
(D)	Probability density of electron at the nucleus in hydrogen like atom	(S)	Electron spin quantum number

Passage based objective questions

Passage :1 (Ques. 5 to 7)

The hydrogen like species Li^{2+} is in a spherically symmetric state S_1 with one radial node. Upon absorbing light the ion undergoes transition to a state S_2 . The state S_2 has one radial node and its energy is equal to the ground state energy of the hydrogen atom. [IIT-2010]

Q.5 The state S_1 is -
(A) 1s (B) 2s (C) 2p (D) 3s

Q.6 Energy of the state S_1 in units of the hydrogen atom ground state energy is -
(A) 0.75 (B) 1.50 (C) 2.25 (D) 4.50

Q.7 The orbital angular momentum quantum number of the state S_2 is -
(A) 0 (B) 1 (C) 2 (D) 3

Q.8 The maximum number of electrons that can have principal quantum number, $n = 3$ and spin quantum number, $m_s = -1/2$, is. [IIT-2011]

Q.9 The work function (ϕ) of some metals is listed below. The number of metals which will show photoelectric effect when light of 300 nm wavelength falls on the metal is. [IIT-2011]

Metal	Li	Na	K	Mg	Cu	Ag	Fe	Pt	W
ϕ (eV)	2.4	2.3	2.2	3.7	4.8	4.3	4.7	6.3	4.75

Q.10 The kinetic energy of an electron in the second Bohr orbit of a hydrogen atom is [a_0 is Bohr radius] [IIT-2012]

(A) $\frac{h^2}{4\pi^2 m a_0^2}$ (B) $\frac{h^2}{16\pi^2 m a_0^2}$
(C) $\frac{h^2}{32\pi^2 m a_0^2}$ (D) $\frac{h^2}{64\pi^2 m a_0^2}$

Q.11 In an atom, the total number of electrons having quantum numbers $n = 4$, $|m_l| = 1$ and $m_s = -1/2$ is [JEE-Advance-2014]

Q.12 Not considering the electronic spin, the degeneracy of the second excited state ($n = 3$) of H atom is 9, while the degeneracy of the second excited state of H^- is - [JEE-Advance-2015]

Q.13 P is the probability of finding the 1s electron of hydrogen atom in a spherical shell of infinitesimal thickness, dr , at a distance r from the nucleus. The volume of this shell is $4\pi r^2 dr$. The qualitative sketch of the dependence of P on r is- [JEE-Advance-2016]

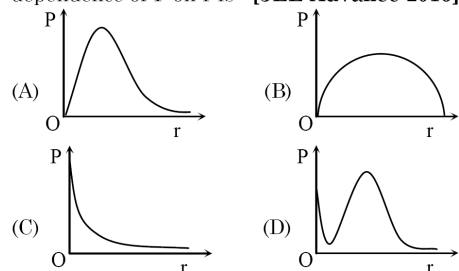

Exercise Level - 6 : Advanced level a bit complex questions for students for solid rock preparation for Top Rankers.

Answer key

Answer key is provided at the end of the exercise sheets.

ANSWER KEY						
EXERCISE (Level-1)						
1. (C)	2. (A)	3. (C)	4. (B)	5. (B)	6. (C)	7. (C)
8. (A)	9. (B)	10. (D)	11. (D)	12. (A)	13. (D)	14. (D)
15. (B)	16. (C)	17. (D)	18. (B)	19. (C)	20. (C)	21. (A)
22. (D)	23. (D)	24. (C)	25. (C)	26. (A)	27. (D)	28. (A)
29. (D)	30. (C)	31. (A)	32. (C)	33. (C)	34. (A)	35. (C)
36. (C)	37. (C)	38. (B)	39. (A)	40. (A)		

Revision Plan

We emphasize that every student should prepare his/her own revision plan. For this purpose there is Revision Plan Section in each chapter which student should prepare while going through the study material. This will be useful at the time of final revision before final exam for quick & effective revision.

Revision Plan

Prepare Your Revision plan today!

After attempting Exercise Sheet, please fill below table as per the instruction given.

- Write Question Number (QN) which you are unable to solve at your own in **column A**.
- After discussing the Questions written in **column A** with faculty, strike off them in the manner so that you can see at the time question number during Revision, to solve such questions again.
- Write down the Question Number you feel are important or good in the **column B**.

EXERCISE	COLUMN A	COLUMN B
	Questions unable to solve in first attempt	Good or Important questions
Topic wise practice questions		
Level-1		
Level-2		
Level-3		
Level-4		
Level-5		
Level-6		

Revision Strategy:

Whenever you wish to revision this chapter, follow the following steps-

Step-1: Review your theory notes.

Step-2: Solve Questions of column A

Online Solutions

Self explanatory and detailed solution of all exercises above are available on Career Point website www.careerpoint.ac.in

ATOMIC STRUCTURE

EXERCISE (Level-1)

Answer Key & Solution

Question Number	Solution
1	Click Here
2	Click Here
3	Click Here
4	Click Here
5	Click Here
6	Click Here
7	Click Here
8	Click Here
9	Click Here
10	Click Here

Question Number	Solution
11	Click Here
12	Click Here
13	Click Here
14	Click Here
15	Click Here
16	Click Here
17	Click Here
18	Click Here
19	Click Here
20	Click Here

Question Number	Solution
21	Click Here
22	Click Here
23	Click Here
24	Click Here
25	Click Here
26	Click Here
27	Click Here
28	Click Here
29	Click Here
30	Click Here

Question Number	Solution
31	Click Here
32	Click Here
33	Click Here
34	Click Here
35	Click Here
36	Click Here
37	Click Here
38	Click Here
39	Click Here
40	Click Here

ATOMIC STRUCTURE

JEE ADVANCED SYLLABUS

1. *Rutherford's model*
2. *Bohr's model*
3. *Quantum numbers*
4. *Electronic configuration of elements (upto atomic number 36) Aufbau principle*
5. *Pauli's exclusion principle and Hund's rule*
6. *Spectrum of hydrogen atom*
7. *de-Broglie relations*
8. *Uncertainty principle*
9. *Quantum mechanical model*
10. *Shapes of s, p and d-orbitals*

Revision Plan

Prepare Your Revision plan today!

After attempting Exercise Sheet, please fill below table as per the instruction given.

- A. Write Question Number (QN) which you are unable to solve at your own in **column A**.
- B. After discussing the Questions written in **column A** with faculty, strike off them in the manner so that you can see at the time question number during Revision, to solve such questions again.
- C. Write down the Question Number you feel are important or good in the **column B**.

	COLUMN A	COLUMN B
EXERCISE	Questions unable to solve in first attempt	Good or Important questions
Topic wise practice questions		
Level-1		
Level-2		
Level-3		
Level-4		
Level-5		
Level-6		

Revision Strategy:

Whenever you wish to revision this chapter, follow the following steps-

Step-1: Review your theory notes.

Step-2: Solve Questions of column A

Step-3: Solve Questions of Column B

Step-4: Solve questions from other Question Bank, Problem book etc.

Atomic Structure

1. INTRODUCTION

- (a) The word atom was first introduced by Ostwald (1803 - 1807) in scientific world.
- (b) According to him matter is ultimately made up of extremely small indivisible particles called atoms.
- (c) It takes part in chemical reactions.
- (d) Atom is neither created nor destroyed

2. DALTON'S ATOMIC THEORY

Dalton proposed the atomic theory on the basis of the law of conservation of mass and law of definite proportions. He also proposed the law of multiple proportion as a logical consequence of this theory. The salient features of this theory are-

- (a) Each element is composed by extremely small particles called atoms.
- (b) Atoms of a particular element are all alike but differ with the atoms of other elements.
- (c) Atom of each element is an ultimate particle, and has a characteristic mass but is structureless.
- (d) Atom is indestructible i.e. it can neither be destroyed nor created by simple chemical reactions.
- (e) Atom of an element takes part in chemical reaction to form molecule.
- (f) In a given compound, the relative number and kind of atom are same.
- (g) Atoms of different elements combine in fixed ratio of small whole numbers to form compound atoms (now called molecules).

◆ Merits and Demerits of Dalton's theory :

A. Merits :

- (a) Dalton's theory explains the law of conservation of mass and some other laws of chemical combination.
- (b) Atoms of elements take part in chemical reaction is true till today.

B. Demerits :

- (a) There is no mention of atomic weights of elements.
- (b) He could not explain that why do atoms of same element combined with each other.
- (c) The law of definite proportion fails if different isotopes are used.

3. EARLIER EFFORTS TO REVEAL STRUCTURE OF ATOM

◆ Evidence for the Electrical nature of matter :

- (a) In 1833 Michael Faraday gave the first important clue about the electrical nature of atoms
- (b) He observed that when electricity is passed through an electrolyte (in the molten state or dissolved state), it undergoes chemical changes.
- (c) This phenomenon is called electrolysis
- (d) Later on in 1874, Stoney pointed out that like matter, electricity is composed of small discrete units of electricity. He proposed the name electron for these discrete units of electricity

◆ Cathode Rays - discovery of electron :

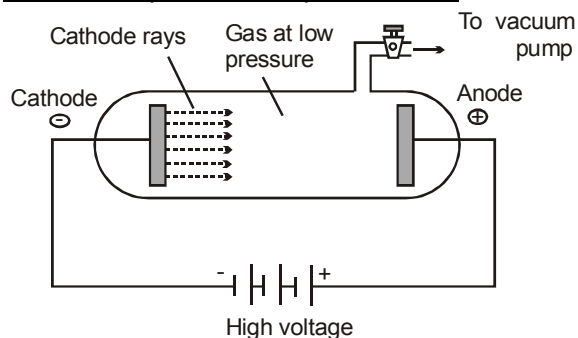

- (a) The electron was discovered as a result of the studies of the passage of electricity through gases at extremely low pressures known as discharge tube experiments.
- (b) In 1859, Julius Plucker started the study of conduction of electricity through gases at low pressure (10^{-4} atm.) in a discharge tube.
- (c) When a high voltage of the order of 10,000 volts or more was impressed across the electrodes, some sort of invisible rays moved from the negative electrode to the positive electrodes these rays are called as cathode rays
- (d) Further investigations were made by W. Crookes, J. Perrin, J.J. Thomson and others.
- (e) Cathode rays have the following properties.
 - (i) Path of travelling is straight from the cathode with a very high velocity. As it produces shadow of an object placed in its path

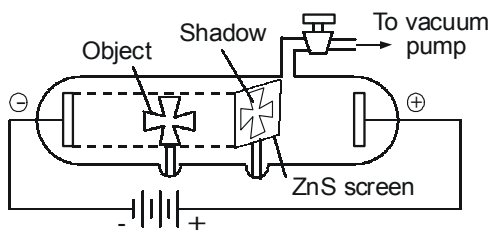

- (ii) Cathode rays produce mechanical effects. If a small paddle wheel is placed between the electrodes, it rotates. This indicates that the cathode rays consist of material part

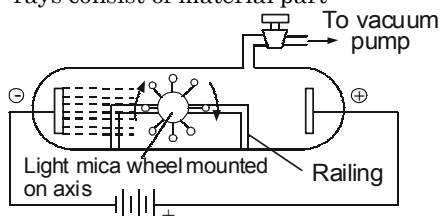

- (iii) When electric and magnetic fields are applied to the cathode rays in the discharge tube, the rays are deflected thus establishing that they consist of charged particles.

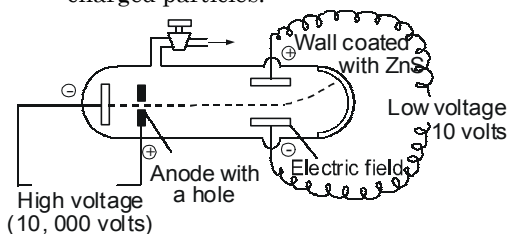

- (iv) Cathode rays produce X-rays when they strike against hard metals like tungsten, copper etc.
- (v) When the cathode rays are allowed to strike a thin metal foil, it gets heated up. Thus the cathode rays possess heating effect.
- (vi) They produce a green glow when strike the glass wall beyond the anode. Light is emitted when they strike the zinc sulphide screen.
- (vii) Cathode rays penetrate through thin sheets of aluminium and other metals.
- (viii) They affect the photographic plates
- (ix) The ratio of charge to mass i.e. charge/mass is same for all the cathode rays irrespective of the gas used in the tube.
- (f) In 1897, J.J. Thomson determined the e/m value (charge/mass) of the electron by studying the deflections of cathode rays in electric and magnetic fields. The value of e/m has been found to be -1.7588×10^8 coulomb/g
- (g) The first precise measurement of the charge on the electron was made by Robert A. Millikan, in 1909 by oil drop experiment. Its value was found to be -1.6022×10^{-19} coulomb.

- (h) The mass of electron can be calculated from the value of e/m and the value of e which is 9.1096×10^{-31} Kg.

◆ **Positive Rays-Discovery of Proton :**

- (a) The existence of positively charged particles in an atom was shown by E. Goldstein in 1886
- (b) He repeated the same discharge tube experiments by using a perforated cathode.
- (c) It was observed that when a high potential difference was applied between the electrodes, not only cathode rays were produced but also a new type of rays were produced simultaneously from anode moving towards cathode and passed through the holes or canal of the cathode. These termed as canal ray or cathode ray

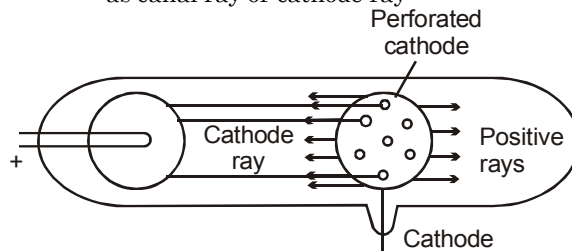

- (d) Characteristics of Anode Rays are as follows.
- (i) These rays travel in straight lines and cast shadow of the object placed in their path.
- (ii) The anode rays are deflected by the magnetic and electric fields like cathode rays but direction is different that mean these rays are positively charged.
- (iii) These rays have kinetic energy and produces heating effect also.
- (iv) The e/m ratio of these rays is smaller than that of electrons
- (v) Unlike cathode rays, their e/m value is dependent upon the nature of the gas taken in the tube.
- (vi) These rays produce flashes of light on Zn-S screen
- (vii) These rays can pass through thin metal foils
- (viii) They are capable to produce ionisation in gases
- (ix) They can produce physical and chemical changes.
- (e) J.J. Thomson in 1906 accurately measured the charge to mass ratio of the particles. He obtained maximum value of e/m hydrogen, because it is the lightest particle. This value was $+9.579 \times 10^4$ coulomb/g
- (f) This was the maximum value for any positive particle & it compelled to assume that the positive particle given by the hydrogen represents a fundamental particle of positive charge. This particle was named proton by Rutherford in 1911.

- (g) Proton carries a charge of $+1.602 \times 10^{-19}$ coulomb, i.e., one unit positive charge.
- (h) Mass of proton is 1.672×10^{-27} kg or 1.0072 amu
- (i) A proton is defined as a sub-atomic particle which has a mass nearly 1 amu and a charge of +1 unit

◆ **Thomson's Model :**

- (Arrangement of electrons and protons in an atom)
- (a) After discovery of electron and proton attempts were made to find out their arrangement in an atom. The first simple model was proposed by J.J. Thomson known as Thomson's atomic model.
 - (b) He proposed that the positive charge is spread over a sphere of the size of the atom (i.e. 10^{-8} cm radius) in which electrons are embedded to make the atom as whole neutral.
 - (c) This model could not explain the experimental results of Rutherford's α -particle scattering, therefore it was rejected.

Example Based on Structure of atom

✎ **Example. 1**

- For cathode rays' the value of e/m
- (A) is independent of the nature of the cathode and the gas filled in the discharge tube
 - (B) is constant
 - (C) is -1.7588×10^8 coulombs/g
 - (D) is lowest when hydrogen gas is filled in discharge tube

Solution. (A), (B), (C)

Cathode rays consists of electrons which are fundamental particles of matter.

✎ **Example. 2**

- Which has highest e/m ratio :
- (A) He^{2+} (B) H^+ (C) He^{1+} (D) H

Solution. (B)

Mass of H^+ is minimum

✎ **Example. 3**

Arrange the following particles in increasing order of values of e/m ratio : Electron (e), proton (p), neutron (n) and α -particle (α)

- (A) n, p, e, α (B) n, α , p, e
- (C) n, p, α , e (D) e, p, n, α

Solution. (B)

	Electron	Proton	Neutron	α -particle
e	1 unit	1 unit	zero	2 unit
m	1/1837 unit	1 unit	1 unit	4 unit
e/m	1837	1	zero	1/2.

✎ **Example. 4**

Mass of neutron is times the mass of electron

- (A) 1840 (B) 1480
- (C) 2000 (D) None

Solution. (A)

mass of neutron = 1.675×10^{-27} kg,
mass of electron = 9.108×10^{-31} kg

4. RUTHERFORD'S EXPERIMENT - (Discovery of nucleus)

Rutherford carried out experiment on the bombardment of atoms by high speed positively charged α - particles emitted from radium and gave the following observations, which was based on his experiment.

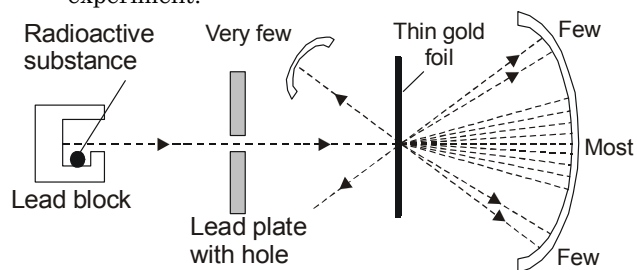

- (a) Most of the α - particles (nearly 99%) continued with their straight path.
- (b) Some of the α - particles passed very close to the centre of the atom and deflected by small angles.
- (c) Very few particles thrown back (180°).

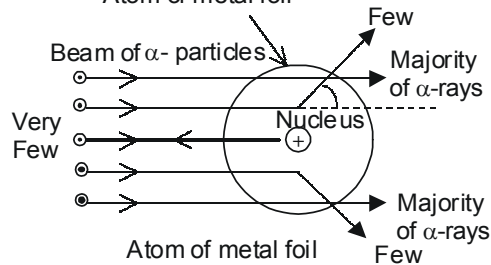

◆ **Main features :**

- (a) Most of the α -particles were continued their straight path that means most of the space of the atom is empty.
- (b) The centre of an atom has a positively charged body called **nucleus** which repel positively charged α -particles and thus explained the scattering phenomenon.
- (c) Whole mass of an atom is concentrated in its nucleus and very few throw back means the size of the nucleus is very small 10^{-13} cm. It showed that the nucleus is 10^{-5} times small in size as compared to the total size of atom.
- (d) The size and volume of the nucleus is very small as compared to the total size and volume of atom.
- (e) As atomic number increases, the angle of deflection (θ) increases.

◆ **Drawbacks of Rutherford's model :**

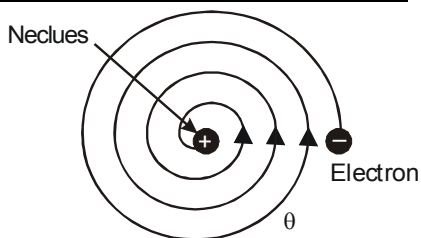

- (a) According to classical electromagnetic theory, when an electron moves around the nucleus under the influence of the attractive force, the electron loses its energy continuously and moves closer and closer to the nucleus in a spiral path, the ultimate result will be that it will fall into the nucleus but it can't be possible because an atom is quite stable.
- (b) If an electron loses energy continuously, the observed spectrum should be continuous but the actual observed spectrum consists of discontinuous well-defined lines of definite frequencies.

Example Based on

Rutherford's Experiment

✎ **Example. 5**

Rutherford's scattering experiment is related to

- (A) Nucleus (B) Atom
(C) Electron (D) Neutron

Solution. (B)

to reveal structure of atom

✎ **Example. 6**

When the atoms of gold sheet are bombarded with a beam of α -particles, only a few α -particles get deflected whereas most of them go straight undeflected. This is because

- (A) The force of attraction on the α -particles by the oppositely charged electron is not sufficient
(B) The nucleus occupies much smaller volume as compared to the volume of atom
(C) the force of repulsion on fast moving α -particles is very small
(D) the neutrons in the nucleus do not have any effect on α -particles.

Solution. (B)

it was the logical conclusion of his experiment.

5. MOSELEY'S EXPERIMENT (Concept of Atomic number)

- (a) After discovery of X-rays by Roentgen in 1895, Moseley (1912 - 13), investigated the X-ray spectra of 38 different elements, starting from aluminium and ending in gold.
- (b) He measured the frequency of principal lines of a particular series (the α -lines in the K series) of the spectra

- (c) He observed that the frequency of a particular spectral line gradually increased with the increase of atomic mass of the element. But finally it was realised that the frequency of a particular line was very much related with the serial number of the element in the periodic table.
- (d) This serial number is termed as atomic number (Z).

He expressed it as $\sqrt{\nu} = a(Z - b)$

where ν = Frequency of X-rays

Z = atomic number, a & b = constants

This relation represents the following curve

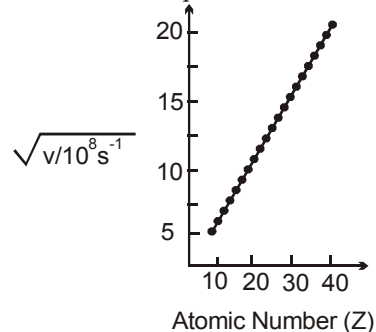

$$a = \sqrt{3Rc/4}$$

Here b is taken into account considering screening due to spherical cloud of the remaining one electron in the K shell

◆ **Atomic number (Z) :**

The number of positive charge carried by the nucleus of an atom is termed as atomic no. (Z) or the number of protons in an atom of an element is equal to its atomic number. Since an atom is electrically neutral it contains an equal number of extra nuclear electrons.

Thus –

Atomic No. = Number of unit positive charge in nucleus = Number of protons = Number of electrons.

◆ **Mass number or Nucleon number (A) :**

The mass number being the sum of the number of protons and neutrons in the nucleus, which is always a whole number.

$$A = P + n \quad \text{or} \quad A = Z + n$$

where :

A = Mass number

P = Number of protons

n = Number of neutrons

Z = Atomic number

On the another side of that statement since mass of a proton or a neutron is not a whole number (on atomic weight scale), atomic weight is not necessarily a whole number.

For example : The isotopes of oxygen having mass number 17 and 18, have atomic weights equal to 17.00045 and 18.0037 respectively.

6. NEUTRON

- (a) This was discovered 20 years after the structure of atom was elucidated by Rutherford.
- (b) It has been found that for all atoms except hydrogen atomic mass is more than the atomic number. Thus Rutherford (1920) suggested that in an atom, there must be present at least a third type of fundamental particle.
- (c) It should be electrically neutral and possess mass nearly equal to that of proton. He proposed its name as neutron.
- (d) Chadwick (1932), bombarded beryllium with a stream of α -particles and observed electrically and magnetically neutral radiations.
- (e) There were neutral particles which were called neutron. Nuclear reaction is as follows
- $${}^9_4\text{Be} + {}^4_2\text{He} \longrightarrow {}^{12}_6\text{C} + {}^1_0\text{n}$$
- (f) A neutron is a subatomic particle which has a mass 1.675×10^{-24} g, approximately 1 amu, or nearly equal to the mass of proton on hydrogen atom and carrying no electrical charge

7. OTHER FUNDAMENTAL PARTICLES

Besides protons, neutrons and electron, many more elementary particles have been discovered. These particles are also called Fundamental particles. Some of these particles are stable (electron, antiproton, positron, neutrino, photon, graviton) while the others are unstable particles (neutron, meson).

The main characteristics of the particles are tabulated below.

$$1 \text{ amu} = 1.66 \times 10^{-27} \text{ kg}$$

$$1 \text{ Coulomb} = 3 \times 10^9 \text{ esu}$$

Example Based on

Moseley's Experiment

Example. 7

If frequency of the X-rays produced using an element as anti-cathode is found to be 2500 sec^{-1} , the atomic number of used element is given that, $a, b = 1$

- (A) 51 (B) 49 (C) 56 (D) 72

Solution. (A)

$$Z = \sqrt{\nu} + 1 \quad (\nu = \text{frequency})$$

$$\text{So } Z = \sqrt{2500} + 1 = 51$$

Example. 8

When beryllium is bombarded with α -particles, extremely penetrating radiations are produced which can not be deflected by electrical or magnetic field. These are -

- (A) Protons (B) α -rays
(C) Neutrons (D) X-rays

Solution. (C)
Neutrons

8. ELECTROMAGNETIC RADIATIONS

Light and other forms of radiant energy propagate without any medium in the space in the form of waves. These waves can be produced by a charged body moving in a magnetic field or a magnet in an electric field. e.g. α - rays, γ - rays, Cosmic rays, Ordinary light rays etc.

Characteristics of electromagnetic radiations :

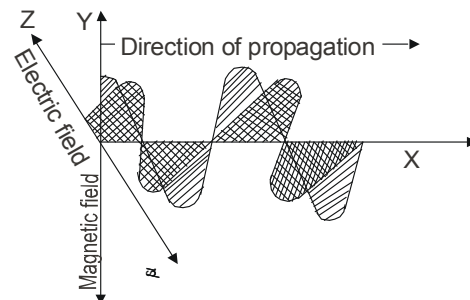

- (a) All electromagnetic waves move or travel with the same velocity equal to that of light.
- (b) They do not require any medium to propagate.
- (c) These consist of electric and magnetic field that oscillate in the direction perpendicular to each other and to the direction in which the wave is propagate.

Some Important characteristics of electromagnetic waves :

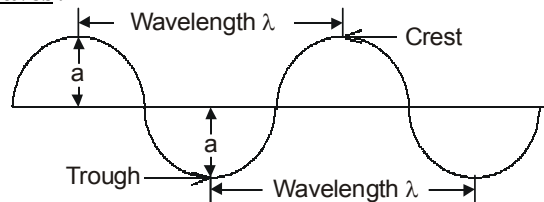

(a) Frequency (ν) :

It is defined as the no. of waves which pass through a given point in per sec. Its unit is expressed by cycle per second (cps) or Hertz (Hz). $\nu = c/\lambda$

NOTE A cycle is said to be completed when a wave consisting of crest and trough passes through a point.

(b) Wavelength (λ) :

The distance between two adjacent crest or troughs of the wave as shown in the fig. It is denoted by lambda (λ) a greek letter and unit is Angstrom (\AA) or nanometer (nm).

$$1 \text{ \AA} = 10^{-10} \text{ m} \text{ or } 10^{-8} \text{ cm}$$

$$1 \text{ nm} = 10^{-9} \text{ m} \text{ or } 10^{-7} \text{ cm}$$

$$\lambda = \frac{c}{\nu}$$

Particle	Symbol	Nature	Charge (in esu) $\times 10^{-10}$	Mass (in amu)	Discovered by
Positron	$e^+, 1e^0, \beta^+$	+	+ 4.8029	0.0005486	Anderson (1932)
Neutrino	ν	0	< 0.00002		Pauli
Anti-proton	p^-	-	4.8029	1.00787	Chamberlain Sugri & Weighland (1955)
Photon	$h\nu$	0	0	0	Planck
Graviton	G	0	0	0	
Positive mu meson	μ^+	+	+ 4.8029	0.1152	Yukawa (1935)
Netative mu meson	μ^-	-	- 4.8029	0.1152	Yukawa (1935)
Positive pi meson	π^+	+	+ 4.8029	0.1514	Powell (1947)
Negative pi meson	π^-	-	- 4.8029	0.1514	
Neutral pi meson	π^0	0	0	0.1454	

(c) **Wave No. ($\bar{\nu}$) :**

It is defined as the number of wave per cm and it is equal to the inverse of wavelength. Its unit is cm^{-1} .

$$\bar{\nu} = \frac{1}{\lambda}, \quad \nu = \frac{c}{\lambda} = c\bar{\nu}$$

(d) **Amplitude (a) :**

It denotes the height of the crest or depth of the trough of a wave. It determines the intensity of brightness of radiation.

(e) **Velocity (v) :**

The distance traveled per sec by a wave called velocity of a wave. It is expressed by the unit of m/sec. or cm/sec.

9. SOLAR SPECTRUM

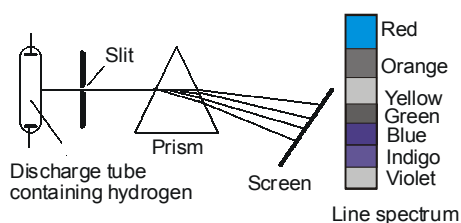

- (a) When sunlight is passed through a prism, It absorbs wavelength range of black colour radiation and other splits into a series of colour bands known as emission spectrum and black colour band which is known as absorption spectrum.
- (b) The splitting of light into seven colours is called emission **Spectrum**.
- (c) The characteristic range of wavelength of electromagnetic radiation situated in an increasing or decreasing order called electromagnetic spectrum.

10. ATOMIC SPECTRA OR LINE SPECTRA

Atomic spectra is line spectra. So atomic spectrum is also called line spectrum. It is of two types.

◆ **Emission spectrum :**

A substance gets excited on heating at a very high temperature or by giving energy and radiations are emitted. These radiations when analysed with the help of spectroscope, spectral lines are obtained. A substance may be excited as follows -

- (a) By heating at a higher temperature.
- (b) By passing electric current at a very low pressure in a discharge tube filled with gas.
- (c) By passing electric current into metallic filament.

Emission spectra is of three types -

- (i) Continuous spectrum
 - (ii) Line spectrum
 - (iii) Band spectrum
- (i) **Continuous spectrum :** When sunlight is passed through a prism, it gets dispersed into continuous bands of different colours. If the light of an incandescent object is resolved through prism or spectroscope, it also gives continuous spectrum of colours.
- (ii) **Line spectrum :** If the radiations obtained by the excitation of a substance are analysed with the help of a spectroscope a series of thin bright lines of specific colours are obtained. There is dark space in between two consecutive lines. This type of spectrum is called line spectrum or atomic spectrum. For example on heating sodium chloride or any other salt of sodium in Bunsen flame bright yellow light is emitted. The emitted light when viewed through a spectroscope two isolated yellow lines separated by dark space are obtained. The wave lengths of these lines are 5890\AA and 5896\AA .
- (iii) **Band spectrum :** it is originated by molecules and linear spectrum is originated by atoms.

◆ **Absorption Spectrum :**

When the white light of an incandescent substance is passed through any other substance, this substance absorbs the radiations of certain wavelength from the white light. On analysing the transmitted light we obtain a spectrum in which dark lines of specific wave lengths are observed. These lines constitute the absorption spectrum. The wave length of the dark lines correspond to the wavelength of light absorbed.

◆ **Difference between Emission and absorption spectra :**

	Emission spectrum	Absorption spectrum
1	It is obtained when radiation emitted by the excited substance which is analysed in a spectroscope.	It is obtained when white light is passed through the substance either gases or in the form of solution.
2	This type of spectrum consist of bright coloured lines separated by dark spaces.	It is consist of dark lines on a colour back ground.

11. HYDROGEN SPECTRUM

- (a) Hydrogen spectrum is an example of line emission spectrum or atomic emission spectrum
- (b) When an electric discharge is passed through hydrogen gas at low pressure, a bluish light is emitted.
- (c) This light shows discontinuous line spectrum of several isolated sharp lines through prism.
- (d) All these lines of H-spectrum have following six series

Spectral Series	Region
Lyman	U.V.
Balmer	Visible
Paschen	IR
Brackett	IR
Pfund	IR
Humphrey	Far I.R.

These spectral series were named by the name of scientist who discovered them

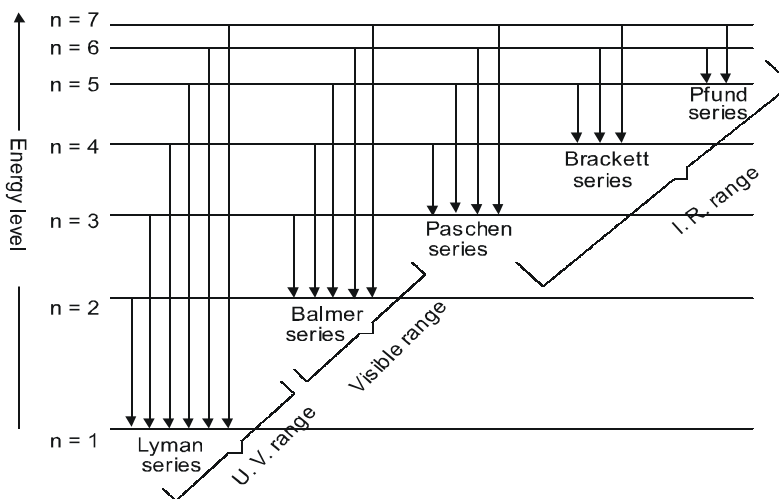

- (e) To evaluate wavelength of various H-lines Ritz introduced the following expression

$$\bar{\nu} = \frac{1}{\lambda} = \frac{\nu}{c} = R \left(\frac{1}{x^2} - \frac{1}{y^2} \right) = R$$

Where R is a universal constant known as Rydberg's constant its value is $109,678 \text{cm}^{-1}$.

- (f) Although H - atom consists only one electron yet it's spectra consist of many spectral lines.

$$\frac{1}{\lambda} = \bar{\nu} = R_H \left[\frac{1}{n_1^2} - \frac{1}{n_2^2} \right]$$

- (g) If an electron from n^{th} excited state comes to first energy states, the maximum spectral lines obtained will be $= \frac{n(n-1)}{2}$

◆ **Lyman Series :**

- (a) It is a first series of spectral series of H.
- (b) It was found out in ultraviolet region in 1898 by *Lyman*.
- (c) It's value of $n_1 = 1$ and $n_2 = 2, 3, 4$ where ' n_1 ' is ground state and ' n_2 ' is called excited state of electron present in a H - atom.
- (d) If the electron goes to $n_1 = 1$ to $n_2 = 2$ — first Lyman series
If the electron goes to $n_1 = 1$ to $n_2 = 3$ — Second Lyman series
If the electron goes to $n_1 = 1$ to $n_2 = 4$ — third Lyman series ...so on.

- (e) $\frac{1}{\lambda} = R_H \left[\frac{1}{1^2} - \frac{1}{n_2^2} \right]$ where $n_2 > 1$ always.

- (f) The wavelength of marginal line $= \frac{n_1^2}{R_H}$ for all series. So, for lyman series $\lambda = \frac{1}{R_H}$

◆ **Balmer series :**

- (a) It is the second series of H-spectral series.
- (b) It was found out in 1892 in visible region by **Balmer**.
- (c) Balmer series was found out before all series. Because it was found to be in visible region.
- (d) It's value of $n_1 = 2$ and $n_2 = 3, 4, 5, \dots, n$ where n_1 is ground state and n_2 is excited state.
- (e) If the electron goes to $n_1 = 2$ to $n_2 = 3$ — First Balmer series
If the electron goes to $n_1 = 2$ to $n_2 = 4$ — Second Balmer series
If the electron goes to $n_1 = 2$ to $n_2 = 5$ — third Balmer series..so on
- (f) The wavelength of marginal line of Balmer series = $\frac{n_1^2}{R_H} = \frac{2^2}{R_H} = \frac{4}{R_H}$
- (g) $\frac{1}{\lambda} = R_H \left[\frac{1}{2^2} - \frac{1}{n_2^2} \right]$ where $n_2 > 2$ always

◆ **Paschen Series :**

- (a) It is the third series of H - spectrum.
- (b) It was found out in infra red region by **Paschen**.
- (c) It's value of $n_1 = 3$ and $n_2 = 4, 5, 6, \dots$ where n_1 is ground state and n_2 is excited state.
- (d) If the electron goes to $n_1 = 3$ to $n_2 = 4$ — First paschen series

If the electron goes to

$n_1 = 3$ to $n_2 = 5$ — second paschen series

If the electron goes to

$n_1 = 3$ to $n_2 = 6$ — third paschen series-----

so on.

- (e) The wavelength of marginal line of paschen series = $\frac{n_1^2}{R_H} = \frac{3^2}{R_H} = \frac{9}{R_H}$
- (f) $\frac{1}{\lambda} = R_H \left[\frac{1}{3^2} - \frac{1}{n_2^2} \right]$ where $n_2 > 3$ always.

◆ **Brackett series :**

- (a) It is fourth series of H - spectrum.
- (b) It was found out in infra red region by **Brackett**.
- (c) It's value of $n_1 = 4$ and $n_2 = 5, 6, 7, \dots$ where n_1 is ground state and n_2 is excited state.
- (d) If the electron goes to $n_1 = 4$ to $n_2 = 5$ — first brackett series
If the electron goes to $n_1 = 4$ to $n_2 = 6$ — second brackett series
If the electron goes to $n_1 = 4$ to $n_2 = 7$ — third brackett series
----- so on.

Name	λ in Å	Origin
Radio waves	3×10^9 to 3×10^{14}	by the Alternating current of high frequency
Microwaves	3×10^6 to 3×10^9	by the generator of high quality
I.R.	7600 to 3×10^6	from the heated things
Visiblewave	3800 to 7600	
U.V. wave	150 to 3800	from the sun rays
α - rays	0.1 to 150	to put a metallic barrier in path of moving electron
γ - rays	0.01 to 0.1	by radio active disintegration
Cosmic rays	0 to 0.01	from the outer most part of sun

λ decreases —
 ν increases —

- (e) The wavelength of marginal line of

brackett series = $\frac{n_1^2}{R_H} = \frac{4^2}{R_H} = \frac{16}{R_H}$

- (f) $\frac{1}{\lambda} = R_H \left[\frac{1}{4^2} - \frac{1}{n_2^2} \right]$ Where $n_2 > 4$ always.

◆ **Pfund Series :**

- (a) It is fifth series of H - spectrum.
- (b) It was found out in infra red region by Pfund.

- (c) It's value of $n_1 = 5$ and $n_2 = 6, 7, 8, \dots$ where n_1 is ground state and n_2 is excited state.

- (d) If the electron goes to $n_1 = 5$ to $n_2 = 6$ — first Pfund series
If the electron goes to $n_1 = 5$ to $n_2 = 7$ — second Pfund series
If the electron goes to $n_1 = 5$ to $n_2 = 8$ — third Pfund series----- so on.

- (e) The wavelength of marginal line of Pfund

$$\text{series} = \frac{n_1^2}{R_H} = \frac{5^2}{R_H} = \frac{25}{R_H}$$

- (f) $\frac{1}{\lambda} = R_H \left[\frac{1}{5^2} - \frac{1}{n_2^2} \right]$ where $n_2 > 5$ always.

◆ **Humfri Series :**

- (a) It is the sixth series of H - spectrum.
 (b) It was found out in infra-red region by *Humfri*.
 (c) It's value of $n_1 = 6$ and $n_2 = 7, 8, 9 \dots$ where n_1 is ground state of electron and n_2 is excited state.
 (d) If the electron goes to $n_1 = 6$ to $n_2 = 7$ — first Humfri series
 If the electron goes to $n_1 = 6$ to $n_2 = 8$ — second Humfri series
 If the electron goes to $n_1 = 6$ to $n_2 = 9$ — third Humfri series so on.
 (e) The wavelength of marginal line of Humfri

$$\text{series} = \frac{n_1^2}{R_H} = \frac{6^2}{R_H} = \frac{36}{R_H}$$

- (f) $\frac{1}{\lambda} = R_H \left[\frac{1}{6^2} - \frac{1}{n_2^2} \right]$ where $n_2 > 6$.

12. CONCEPT OF QUANTIZATION

- (a) E.M. wave theory successfully explains about reflection, refraction, diffraction, etc. but it fails to explain black body radiations and photo electric effect
 (b) To explain all these things Max planck gave a new revolutionary theory in 1901, called as quantum theory of radiation.
 (c) According to this theory, a hot body emits radiant energy not continuously but discontinuously in the form of small packets of energy called quantum.
 (d) In case of light, the quantum of energy is often called photon.
 (e) The amount of energy associated with a quantum radiation is proportional to the frequency of light
 $E \propto \nu$ or $E = h\nu$
 where the proportionality constant, h is a universal constant known as Planck's constant. Its value is 6.63×10^{-34} J-sec
 (f) The total amount of energy emitted or absorbed by a body will be some whole number multiple of quantum, i.e. $E = nh\nu$
 where n is an integer such as 1, 2, 3

Example Based on

E.M. Radiation and Spectrum

✎ **Example. 9**

The wavelengths of two photons are 2000\AA and 4000\AA respectively. What is the ratio of their energies ?

- (A) 1/4 (B) 4 (C) 1/2 (D) 2

Solution. (D)

$$E_1 = h \cdot \frac{c}{\lambda_1} ; \quad E_2 = h \cdot \frac{c}{\lambda_2}$$

$$\frac{E_1}{E_2} = \frac{hc}{\lambda_1} \times \frac{\lambda_2}{hc} = \frac{\lambda_2}{\lambda_1} = \frac{4000}{2000} = 2$$

✎ **Example. 10**

There are three energy levels in an atom. How many spectral lines are possible in its emission spectra ?

- (A) One (B) Two
 (C) Three (D) Four

Solution. (C)

$$\text{Number of spectral lines} = \frac{n(n-1)}{2} = \frac{3(3-1)}{2} = 3$$

✎ **Example. 11**

Which of the following transitions will emit the photons of highest frequency in hydrogen atom ?

- (A) From $n = 1$ to $n = 2$
 (B) From $n = 2$ to $n = 1$
 (C) From $n = 2$ to $n = 6$
 (D) From $n = 6$ to $n = 2$

Solution. (B)

The emission of photon is due to the transition of electrons from higher to lower energy levels. So the answer may be (2) or (4). From Planck's equation. $\nu \propto E$

i.e. The frequency of emitted photon is directly proportional to the difference of energies of two energy levels.

Energy of $n = 1$ for H-atom

$$E_1 = -13.6 \text{ eV}$$

Energy of $n = 2$ for H-atom

$$E_2 = -\frac{13.6}{4} \text{ eV}$$

Energy of $n = 6$ for H-atom

$$E_6 = -\frac{13.6}{36} \text{ eV}$$

$$\text{So } E_2 - E_1 = 13.6 - \frac{13.6}{4} = 13.6 \times \frac{3}{4}$$

$$E_6 - E_2 = \frac{13.6}{4} - \frac{13.6}{36} = 13.6 \left(\frac{1}{4} - \frac{1}{36} \right)$$

$$= 13.6 \times \frac{2}{9}$$

$$E_2 - E_1 > E_6 - E_2$$

Example. 12

Which type of radiation is not emitted by the electronic structure of atoms :

- (A) Ultraviolet light (B) X-rays
(C) Visible light (D) γ -rays

Solution. (D)

γ -rays emission occurs due to radioactive change, a nuclear phenomenon.

Example. 13

The wavelength of blue light is 480 nm. Calculate the frequency and wave number of this light.

Solution.

Wavelength of blue light (λ) = 480 nm
= 480×10^{-9} m

We know that frequency (ν) is related to wavelength as :

$$\lambda \times \nu = c \quad \text{or} \quad \nu = \frac{c}{\lambda}$$

Where, c, velocity of light = $3.0 \times 10^8 \text{ ms}^{-1}$

$$\therefore \nu = \frac{3.0 \times 10^8 \text{ ms}^{-1}}{480 \times 10^{-9} \text{ m}} = \frac{3}{48} \times 10^{16} \text{ s}^{-1}$$
$$= 6.25 \times 10^{14} \text{ s}^{-1}$$

Again, wave number, $\bar{\nu} = \frac{1}{\lambda}$

$$\therefore \bar{\nu} = \frac{1}{480 \times 10^{-9} \text{ m}} = \frac{1}{48} \times 10^8 \text{ m}^{-1}$$
$$= 2.08 \times 10^6 \text{ m}^{-1}$$

Therefore, frequency = $6.25 \times 10^{14} \text{ s}^{-1}$ and
wave number = $2.08 \times 10^6 \text{ m}^{-1}$

Example. 14

Calculate and compare the energies of two radiations one with a wavelength of 800 nm and other with wavelength of 400 nm.

Solution.

Energy of photon, $E = h\nu = \frac{hc}{\lambda}$

Here $c = 3.0 \times 10^8 \text{ m s}^{-1}$

In first case, $\lambda = 800 \text{ nm} = 800 \times 10^{-9} \text{ m}$

$$\therefore E_1 = \frac{(6.626 \times 10^{-34} \text{ Js}) \times (3 \times 10^8 \text{ ms}^{-1})}{800 \times 10^{-9} \text{ m}}$$
$$= 2.48 \times 10^{-19} \text{ J}$$

In second case, $\lambda = 400 \text{ nm} = 400 \times 10^{-9} \text{ m}$

$$\therefore E_2 = \frac{(6.626 \times 10^{-34} \text{ Js}) \times (3 \times 10^8 \text{ ms}^{-1})}{400 \times 10^{-9} \text{ m}}$$
$$= 4.91 \times 10^{-19} \text{ J}$$

Ratio of energy of first and second radiations,

$$\frac{E_1}{E_2} = \frac{2.48 \times 10^{-19} \text{ J}}{4.97 \times 10^{-19} \text{ J}} = \frac{1}{2}$$

$$E_1 : E_2 = 1 : 2 \quad \text{or} \quad E_2 = 2E_1$$

Thus, energy of the radiation with wavelength 400 nm is twice that of the radiation of wavelength 800 nm.

13. BOHR'S ATOMIC MODEL

Bohr developed atomic model for hydrogen and hydrogen like one electron species on the basis of Planck's quantum theory.

◆ The important postulates of Bohr model of an atom :

- (a) Electron revolves around the nucleus in a fixed circular orbit of definite energy.

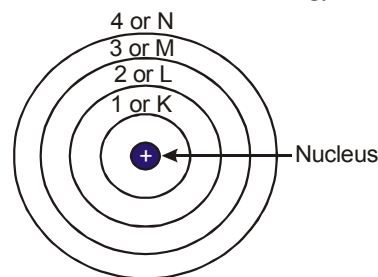

- (b) Electron revolves only in those orbits whose angular momentum (mvr) is an integral multiple of the factor $h/2\pi$ (where 'h' is Planck's constant)

$$mvr = n \frac{h}{2\pi}$$

where : -

m = mass of the electron

v = velocity of the electron

n = number of orbit in which electron revolves i.e. n = 1, 2, 3

r = radius of the orbit.

- (c) As long as the electron occupy a definite energy level, it does not radiate out energy i.e. it does not lose or gain energy.

- (d) The energy is emitted or absorbed only when the electron jumps from one energy level to another. If energy is supplied to an electron, It may jump higher energy level to the lower by the emission of energy. This higher energy level called excited state. Similarly in the reverse process it may absorb energy and jump from lower to higher energy level.

This amount of energy emitted or absorbed is given by the difference of the energies of the two energy levels concerned.

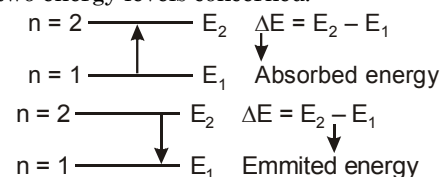

◆ **Mathematical term of Bohr's Postulates :**

A. Calculation of the radius of the Bohr's orbit :

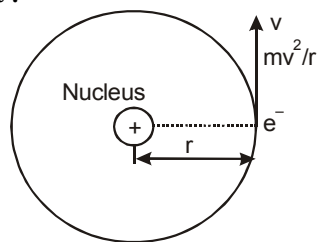

Suppose that an electron having mass 'm' and charge 'e' revolving around the nucleus of charge 'Ze' (Z is atomic number & e = charge) with a tangential / linear velocity of 'v'. Further consider that 'r' is the radius of the orbit in which electron is revolving. According to **Coulomb's law**, the electrostatic force of attraction (F) between the moving electron and nucleus is -

$$F = \frac{KZe^2}{r^2}$$

Where :- $K = \text{constant} = \frac{1}{4\pi\epsilon_0}$

and the centrifugal force $F = \frac{mv^2}{r}$

For the stable orbit of an electron both the forces are balanced,

i.e. at equilibrium $\frac{mv^2}{r} = \frac{KZe^2}{r^2}$ then

$$v^2 = \frac{KZe^2}{mr} \quad \dots(1)$$

From the postulate of Bohr,

$$mvr = \frac{nh}{2\pi}, \quad v = \frac{nh}{2\pi mr}, \quad v^2 = \frac{n^2 h^2}{4\pi^2 m^2 r^2} \quad \dots(2)$$

From equation (1) and (2) ;

$$\frac{KZe^2}{mr} = \frac{n^2 h^2}{4\pi^2 m^2 r^2}$$

on solving, we will get $r = \frac{n^2 h^2}{4\pi^2 mZe^2}$

In C.G.S. unit $K = 1$,

$$\therefore r = \frac{n^2 h^2}{4\pi^2 mZe^2}$$

where ; $h = 6.62 \times 10^{-27}$ erg. sec.

$$m = 9.1 \times 10^{-28} \text{ g}$$

$$e = 1.6 \times 10^{-19} \text{ C.}$$

on putting the value of e, h, m then

$$r = 0.529 \times \frac{n^2}{Z} \text{ \AA}$$

Orbital frequency $f = \frac{v}{2\pi r}$

B. Calculation of velocity of an electron in Bohr's orbit :

Velocity of the revolving electron in n^{th} orbit is given by -

$$mvr = \frac{nh}{2\pi} \Rightarrow v = \frac{nh}{2\pi mr} \quad (1)$$

To put the value of 'r' on the equation (1)

$$\text{then } v = \frac{nh \times \pi^2 mZe^2}{2\pi mn^2 h^2}, \quad v = \frac{2\pi Ze^2}{nh}$$

on putting the values of π , e^- and h

$$v = 2.188 \times 10^8 \times \frac{Z}{n} \text{ Cm/sec.}$$

$$v \propto Z, \quad v \propto \frac{1}{n}$$

C. Calculation of energy of an electron :

The K.E. of an electron = $\frac{1}{2} mv^2$

and the P.E. of an electron = $-\frac{kZe^2}{r}$

Hence, $T.E. = \frac{1}{2} mv^2 - \frac{kZe^2}{r}$

We know that,

$$\frac{mv^2}{r} = \frac{kZe^2}{r^2} \quad \text{or} \quad mv^2 = \frac{kZe^2}{r}$$

substituting the value of mv^2 in the above equation :-

$$T.E. = \frac{kZe^2}{2r} - \frac{kZe^2}{r} = -\frac{kZe^2}{2r}$$

So, $T.E. = -\frac{kZe^2}{2r}$

In C.G.S. unit $K = 1$

$$\therefore T.E. = -\frac{Ze^2}{2r}$$

Substituting the value of 'r' in the equation of T.E. .

$$\text{Then, } E = -Ze^2 \times \frac{4\pi^2 Ze^2 m}{n^2 h^2} = -\frac{2\pi^2 Z^2 e^4}{n^2 h^2}$$

Thus, the total energy of an electron in n^{th} orbit is given by

$$E_n = -\frac{2\pi^2 Z^2 e^4 m}{n^2 h^2}$$

NOTE → The P.E. at the infinite = 0
The K.E. at the infinite = 0

D. Relation between P. E., K. E. & T. E. :

$$P. E. = -\frac{Ze^2}{r}, \quad K. E. = \frac{1}{2} \frac{Ze^2}{r},$$

$$T. E. = \frac{1}{2} \frac{Ze^2}{r}$$

$$\text{So, } \frac{\text{T.E.}}{\text{P.E.}} = \frac{-\frac{1}{2} \frac{Ze^2}{r}}{-\frac{Ze^2}{r}} = \frac{1}{2}$$

$$\text{Then } \text{T. E.} = 1/2 \text{ P. E.} \quad \dots (1)$$

$$\frac{\text{T.E.}}{\text{K.E.}} = \frac{-\frac{1}{2} \frac{Ze^2}{r}}{\frac{1}{2} \frac{Ze^2}{r}} = -1$$

$$\text{Then } \text{T. E.} = -\text{K. E.} \quad \dots (2)$$

$$\text{T. E.} = \frac{\text{P.E.}}{2} = -\text{K. E.} \quad \dots (3)$$

$$(a) \text{ T. E.} = -13.6 \times \frac{Z^2}{n^2} \text{ eV / atom}$$

$$(b) \text{ T. E.} = -21.8 \times 10^{-19} \times \frac{Z^2}{n^2} \text{ J / atom}$$

$$(c) \text{ T. E.} = -21.8 \times 10^{-12} \times \frac{Z^2}{n^2} \text{ erg / atom}$$

$$(d) \text{ T. E.} = -313.6 \times \frac{Z^2}{n^2} \text{ Kcal / mole}$$

$$\text{T. E.} \propto -Z^2 \quad Z \uparrow \text{ T. E.} \downarrow$$

$$\text{T. E.} \propto -\frac{1}{n^2} \quad n \uparrow \text{ T. E.} \uparrow$$

E. Conclusions from equation of energy :

- The negative sign of energy indicates that there is attraction between the negatively charged electron and positively charged nucleus.
- All the quantities of R.H.S. in the energy equation are constant for an element except 'n' which is an integer such as 1, 2, 3 etc. i. e. the energy of an electron is constant as long as the value of 'n' is kept constant.
- The energy of an electron is inversely proportional to the square of 'n' with negative sign.

◆ Calculation of Rydberg Constant :

Suppose that an electron transist from first energy level to second energy level. Then, the change of energy is given by

$$\Delta E = E_2 - E_1$$

$$h\nu = E_2 - E_1$$

$$h\nu = \left[\frac{-2\pi^2 mZ^2 e^4}{n_2^2 h^2} \right] - \left[\frac{-2\pi^2 mZ^2 e^4}{n_1^2 h^2} \right]$$

$$h\nu = \frac{2\pi^2 mZ^2 e^4}{n_1^2 h^2} - \frac{2\pi^2 mZ^2 e^4}{n_2^2 h^2}$$

$$\therefore \nu = \frac{c}{\lambda}$$

$$\frac{hc}{\lambda} = \frac{2\pi^2 mZ^2 e^4}{h^2} \times \left[\frac{1}{n_1^2} - \frac{1}{n_2^2} \right]$$

$$R_H = \frac{2\pi^2 me^4}{ch^3} \Rightarrow \text{Rydberg constant}$$

Then,

$$\text{Where } m = 9.1 \times 10^{-28} \text{ gram}$$

$$e = 4.8 \times 10^{-10} \text{ e.s.u.}$$

$$c = 3 \times 10^{10} \text{ cm/sec}$$

$$h = 6.625 \times 10^{-27} \text{ erg-sec}$$

by the theoretical value of $R_H = 109737 / \text{cm}$

by the practical value of $R_H = 109677 / \text{cm}$

by the calculative value of $R_H = 109700 / \text{cm}$

Rydberg constant for other atom $R = R_H \times Z^2$

◆ Failures / Limitations of Bohr's theory :

- He could not explain the line spectra of atoms containing more than one electron.
- He also could not explain the presence of multiple spectral lines.
- He was unable to explain the splitting of spectral lines in magnetic field (*Zeeman effect*) and in electric field (*Stark effect*).
- No one conclusion was given for the principle of quantisation of angular momentum.
- He was unable to explain the *de-Broglie's* concept of dual nature of matter.
- He could not explain *Heisenberg's* uncertainty principle.

Example Based on

Bohr's Atomic Model

Example. 15

The energy of electron in first Bohr's orbit of H-atom is -13.6 eV . What will be its potential energy in $n = 4$.

$$(A) -13.6 \text{ eV}$$

$$(B) -3.4 \text{ eV}$$

$$(C) -0.85 \text{ eV}$$

$$(D) -1.70 \text{ eV}$$

Solution. (D)

Energy of n^{th} Bohr's orbit of H-atom

$$= -13.6 \frac{Z^2}{n^2} \text{ eV} = -13.6 \frac{1^2}{4^2}$$

$$= 13.6 \times \frac{1}{16} \text{ eV} = -0.85 \text{ eV}$$

P.E. of electron in n^{th} orbit = $2 \times E_n$

So P.E. of electron in 4^{th} orbit

$$= 2 \times (-0.85) = -1.70 \text{ eV}$$

Example. 16

The frequency of line spectrum of sodium is $5.09 \times 10^{14} \text{ sec}^{-1}$. Its wave length (in nm) will be- [$c = 3 \times 10^8 \text{ m/sec}$]

$$(A) 510 \text{ nm}$$

$$(B) 420 \text{ nm}$$

$$(C) 589 \text{ nm}$$

$$(D) 622 \text{ nm}$$

Solution. (C)

$$\lambda = \frac{3 \times 10^8 \text{ m. sec}^{-1}}{5.09 \times 10^{14} \text{ m. sec}^{-1}} = 0.5892 \times 10^{-6} \text{ m}$$

$$= 589.4 \times 10^{-9} \text{ m} = 589 \text{ nm}$$

Example. 17

The spectrum of He-atom may be considered similar to the spectrum of -

- (A) H (B) Li⁺
(C) Na (D) He⁺

Solution. (B)

The electronic configuration of He is similar to the electronic configuration of Li⁺. So its spectrum will be similar to the spectrum of Li⁺ and answer will be (B).

Example. 18

Supposing the energy of fourth shell for hydrogen atom is - 50 a.u. (arbitrary unit). What would be its ionization potential -

- (A) 50 (B) 800 (C) 15.4 (D) 20.8

Solution.

Ionization potential = $-E_1$

$$\therefore E_4 = \frac{E_1}{16}$$

$$\therefore -50 \times 16 = E_1$$

Hence ionization potential = $-(-800) = 800$ a.u.

Example. 19

Find the wavelengths of the first line of He⁺ ion spectral series whose interval with extreme lines is

$$\frac{1}{\lambda_1} - \frac{1}{\lambda_2} = 2.7451 \times 10^4 \text{ cm}^{-1}$$

Solution.

Extreme lines means first and last.

$$\frac{1}{\lambda_1} - \frac{1}{\lambda_2} = RZ^2 \left[\frac{1}{n_1^2} - \frac{1}{\infty^2} \right] = RZ^2$$

$$\left[\frac{1}{n_1^2} - \frac{1}{(n_1 + 1)^2} \right] = \frac{RZ^2}{(n_1 + 1)^2}$$

$$2.7451 \times 10^4 = \frac{109677.76 \times 2^2}{(n_1 + 1)^2}$$

$$(n_1 + 1) = 4$$

$$n_1 = 3$$

Wavelength of first line,

$$\frac{1}{\lambda} = 109677.76 \times 2^2 \times \left[\frac{1}{3^2} - \frac{1}{4^2} \right]$$

$$\lambda = 4689 \times 10^{-8} \text{ cm} = 4689 \text{ \AA}$$

Example. 20

The first ionization potential of hydrogen is 13.6 eV. It is exposed to electromagnetic radiation of 1028 \AA and gives out induced radiations. Calculate the wavelength of these induced radiations ($h = 6.625 \times 10^{-34} \text{ Js}$)

Solution.

We know that

$$E_n = \frac{E_1}{n^2}$$

$$E_n = \frac{6.625 \times 10^{-34} \times 3 \times 10^8}{1028 \times 10^{-10}} = 1.933 \times 10^{-18} \text{ J}$$

$$= 12.07 \text{ eV}$$

$$(1.6 \times 10^{-19} \text{ J} = 1 \text{ eV})$$

Energy of H-atom after excitation

$$= -13.6 + 12.07 = -1.53 \text{ eV}$$

$$\text{From (1), } -1.53 = \frac{E_1}{n^2} = \frac{-13.6}{n^2}$$

$$\therefore n = 3$$

First induced wavelength,

$$\lambda_1 = \frac{hc}{E_3 - E_1} = \frac{6.625 \times 10^{-34} \times 3 \times 10^8}{(-1.53 + 13.6) \times 1.602 \times 10^{-19}}$$

$$= 1025 \times 10^{-10} \text{ m} = 1025 \text{ \AA}$$

Second induced wavelength

$$\lambda_2 = \frac{hc}{E_2 - E_1} = \frac{6.625 \times 10^{-34} \times 3 \times 10^8}{(-3.4 + 13.6) \times 1.602 \times 10^{-19}}$$

$$= 1216 \times 10^{-10} \text{ metre} = 1216 \text{ \AA}$$

Third induced wavelength,

$$\lambda_3 = \frac{hc}{E_3 - E_2} = \frac{6.625 \times 10^{-34} \times 3 \times 10^8}{(-1.53 + 3.4) \times 1.602 \times 10^{-19}}$$

$$= 6564 \times 10^{-10} \text{ m}$$

$$= 6564 \text{ \AA}$$

14. PHOTOELECTRIC EFFECT

When light of suitable frequency falls on the surface of a metal electrons are emitted. These emitted electrons are called as photoelectrons and this effect is called photoelectron. Work function or threshold energy may be defined as the minimum amount of energy required to eject electrons from a metal surface. According to Einstein,

Maximum kinetic energy of the ejected electron = absorbed energy - work function

$$\frac{1}{2} m v_{\max}^2 = h\nu - h\nu_0 = hc \left[\frac{1}{\lambda} - \frac{1}{\lambda_0} \right]$$

Where ν_0 and λ_0 are threshold frequency and threshold wavelength.

- ◆ **Stopping potential** : The minimum potential at which the plate photoelectric current becomes zero is called stopping potential.

If V_0 is the stopping potential, then $eV_0 = h(\nu - \nu_0)$

15. DUAL NATURE OF ELECTRON

(a) Einstein had suggested that light can behave as a wave as well as like a particle i.e. it has dual character

(b) In 1924, de-Broglie proposed that an electron, behaves both as a material particle and as a wave.

(c) This proposed a new theory wave mechanical theory of matter. According to this theory, the electrons protons and even atom when in motion possess wave properties

(d) According to de-Broglie, the wavelength associated with a particle of mass m , moving with velocity v is given by the relation,

$$\lambda = \frac{h}{mv}$$

where h is Planck's constant.

(e) This can be derived as follows according to Planck's equation

$$E = hv = \frac{h.c}{\lambda}$$

Energy of photon on the basis of Enstein's mass energy relationship

$$E = mc^2$$

$$\text{Equating both } \frac{h.c}{\lambda} = mc^2 \text{ or } \lambda = \frac{h}{mc}$$

Which is the same of de Broglie relation.

(f) This was experimentally verified by Davisson and Germer by observing diffraction effects with an electron beam. Let the electron is accelerated with a potential of V than the kinetic energy is

$$\frac{1}{2}mv^2 = eV$$

$$m^2v^2 = 2eVm$$

$$mv = \sqrt{2eVm} = p$$

$$\lambda = \frac{h}{\sqrt{2eVm}}$$

(g) If we associate Bohr's theory with de-Broglie Equation we find that the wavelength of an electron, moving in bohr's orbit is related with its circumference through a whole number multiple

$$2\pi r = n\lambda \text{ or } \lambda = \frac{2\pi r}{n}$$

From de-Broglie equation

$$\lambda = \frac{h}{mv}$$

$$\text{Thus } \frac{h}{mv} = \frac{2\pi r}{n} \text{ or } mvr = \frac{nh}{2\pi}$$

Example Based on

Dual nature of electron

Example. 21

If the Planck's constant $h = 6.6 \times 10^{-34}$ Js, the de-Broglie wavelength of a particle having momentum of 3.3×10^{-24} kg m s⁻¹ will be -

- (A) 0.002 Å (B) 0.02 Å
(C) 0.2 Å (D) 2 Å

Solution. (D)

$$\lambda = \frac{h}{mv}$$

Example. 22

K.E. of the electron is 4.55×10^{-25} J. Its de Broglie wave length is

- (A) 4700 Å (B) 8300 Å
(C) 7285 Å (D) 7400 Å

Solution. (C)

$$\lambda = \frac{h}{\sqrt{2mKE}}$$

Example. 23

For particles having same kinetic energy, the de Broglie wavelength is

- (A) directly proportional to its velocity
(B) inversely proportional to its velocity
(C) independent of velocity and mass
(D) unpredictable

Solution. (A)

$$\lambda = \frac{h}{mv} \text{ KE} = \frac{1}{2}mv^2$$

$$mv = \frac{2KE}{v}$$

$$\therefore \lambda = \frac{h}{2 \frac{KE}{v}}$$

$$\lambda = h \left(\frac{v}{2KE} \right)$$

Example. 24

Velocity of helium atom at 300K is 2.40×10^2 meter per sec. What is its wave length? (mass number of helium is 4) -

- (A) 0.416 nm (B) 0.83 nm
(C) 803 Å (D) 8000 Å

Solution. (A)

$$\lambda = \frac{h}{mv}$$

$$\text{mass of helium} = \frac{4.0 \times 10^{-3}}{6.023 \times 10^{23}} \text{ kg. and}$$

$$h = 6.62 \times 10^{-34}$$

$$\lambda = 6.62 \times 10^{-34} \times \frac{6.023 \times 10^{23}}{4.0 \times 10^{-3}} \times \frac{1}{2.4 \times 10^2}$$

$$= 0.416 \times 10^{-9} \text{ meter}$$

$$\lambda = 0.416 \text{ nm}$$

16. HEISENBERG'S UNCERTAINTY PRINCIPLE

- (a) While treating e^- as a wave it is not possible to ascertain simultaneously the exact position and velocity of the e^- more precisely at a given instant since the wave is extending throughout a region of space

- (b) As the photons of longer wavelengths are less energetic, hence they have less momentum and cannot be located exactly
- (c) In 1927, Werner Heisenberg presented a principle known as Heisenberg's uncertainty principle
- (d) According to this principle it is impossible to measure simultaneously the exact position and exact momentum of a body as small as an electron.
- (e) If uncertainty of measurement of position is Δx uncertainty of momentum is Δp or ΔmV . then according to Heisenberg

$$\Delta x \cdot \Delta p \geq \frac{h}{4\pi} \quad \text{or} \quad \Delta x \cdot \Delta m v \geq \frac{h}{4\pi}$$

where h is planck's constant

- (f) For other canonical conjugates of motion the equation for Heisenberg's uncertainty principle may be given as

$$\Delta E \Delta t \geq \frac{h}{4\pi} \quad (\text{for energy and time})$$

$$\Delta \phi \Delta \theta \geq \frac{h}{4\pi} \quad (\text{for angular motion})$$

Example Based on

Heisenberg's Uncertainty Principle

Example. 25

If uncertainty in position and momentum are equal, the uncertainty in velocity is :

- (A) $\sqrt{h/2\pi}$ (B) $\frac{1}{2m}\sqrt{h/\pi}$
- (C) $\sqrt{h/\pi}$ (D) None of these

Solution. (B)

$$\Delta x \cdot m \Delta v = \frac{h}{4\pi} \quad \text{or} \quad (m \Delta v)^2 = \frac{h}{4\pi}$$

$$m \Delta v = \sqrt{\frac{h}{4\pi}} \quad \text{or} \quad \Delta v = \sqrt{\frac{h}{4\pi m^2}} = \frac{1}{2m} \sqrt{\frac{h}{\pi}}$$

Example. 26

The uncertainty in position and velocity of a particle are 10^{-10} m and $5.27 \times 10^{-24} \text{ ms}^{-1}$ respectively. Calculate the mass of the particle ($h = 6.625 \times 10^{-34} \text{ J-s}$)

Solution.

According to Heisenberg's uncertainty principle,

$$\Delta x \cdot m \Delta v = \frac{h}{4\pi}$$

$$\text{or } m = \frac{h}{4\pi \Delta x \cdot \Delta v}$$

$$= \frac{6.625 \times 10^{-34}}{4 \times 3.143 \times 10^{-10} \times 5.27 \times 10^{-24}} = 0.099 \text{ kg.}$$

17. SCHRODINGER WAVE THEORY

Bohr's theory is based on the corpuscular nature of electron. This theory violates de-Broglie's relation and the uncertainty principle. Hence this theory is replaced by more complete theory called motion in one direction is

$$\left(\frac{\partial \Psi}{\partial x^2} \right)_t = \frac{1}{u^2} \left(\frac{\partial^2 \Psi}{\partial t^2} \right)_x \quad \dots (1)$$

Where ' Ψ ' is the amplitude of vibration at any point whose co-ordinate is ' x ' at a time ' t '.

u = speed of propagation of the wave.

if ' u ' does not depend on the time, the displacement ' Ψ ' can be written as a product of two functions one depending only on the space co-ordinates ' x ' and the other depending periodically on the time.

Thus we have

$$\Psi = \Psi(x) \exp \{i(2\pi vt)\} \quad \dots (2)$$

Where ' v ' is frequency of the wave and

$$i = \sqrt{-1}$$

From equations (1) and (2) we have

$$\left(\frac{\partial^2 \Psi \exp \{i(2\pi vt)\}}{\partial x^2} \right)_t = \frac{1}{u^2} \left(\frac{\partial^2 \Psi \exp \{i(2\pi vt)\}}{\partial t^2} \right)_x$$

$$\text{or } \exp \{i(2\pi vt)\} \frac{\partial^2 \Psi}{\partial x^2}$$

$$= \frac{1}{u^2} \Psi (2\pi v)^2 \exp \{i(2\pi vt)\}$$

$$\text{or } \frac{\partial^2 \Psi}{\partial x^2} = -\frac{4\pi^2 v^2}{u^2} \Psi \quad \dots (3)$$

Relation between frequency of vibration ' v ' and speed is are related by the equation

$$u = \lambda v \quad \dots (4)$$

where ' λ ' is wavelength of the associated wave

From equation (3) and (4) we have

$$\frac{\partial^2 \Psi}{\partial x^2} = -\frac{4\pi^2}{\lambda^2} \Psi \quad \dots (5)$$

Equation (5) does not include the time variable $\exp \{i(2\pi vt)\}$ and thus gives only the variation of the amplitude function with ' x '.

In Equation (5) term $\frac{\partial^2}{\partial x^2}$ is an operator which on operating on the function ' Ψ ' gives back the

function ' Ψ ' multiplied by a constant $-\frac{4\pi^2}{\lambda^2}$. The

equation of the type is called as eigen value equation, the function Ψ is an eigen function and the constant $(-\frac{4\pi^2}{\lambda^2})$ is an eigen value (sometimes it is also called characteristic value). The function ' Ψ ' has acceptable solution only if it has to be consistent with the basic constraints. In case of a vibrating string, these are :

- A. The function ‘ Ψ ’ must be zero at end of the string, since the system is fixed at these points and thus amplitudes are zero.
- B. The ‘ Ψ ’ must be a single valued and finite between the limits of ‘ x ’ varying from one end to the other Equation (5) can be extended to three dimensions as

$$\frac{\partial^2 \Psi}{\partial x^2} + \frac{\partial^2 \Psi}{\partial y^2} + \frac{\partial^2 \Psi}{\partial z^2} = -\frac{4\pi^2}{\lambda^2} \Psi \dots (6)$$

$$\text{or } \nabla^2 \Psi + \frac{4\pi^2}{\lambda^2} \Psi = 0 \dots (7)$$

$$\text{where } \nabla^2 = \frac{\partial^2}{\partial x^2} + \frac{\partial^2}{\partial y^2} + \frac{\partial^2}{\partial z^2}$$

∇^2 is called as Laplacian operator

Equation (7) can be applied to all subatomic particles (Electrons, protons etc.) in an atom. In order that this equation also takes case of wave-particle dual nature, Schrödinger replaced ‘ λ ’ is terms of momentum by using the de-Broglie’s

relation, $\lambda = \frac{h}{p}$ with, this equation (7) becomes

$$\nabla^2 \Psi + \frac{4\pi^2 p^2}{h^2} \Psi = 0 \dots (8)$$

For an electron in an atom, the total energy of the electron is the sum of its kinetic and potential energies.

$$E = KE + PE = \frac{1}{2} + V \quad \text{or} \quad E = \frac{P^2}{2m} + V$$

$$P^2 = 2m(E - V) \dots (9)$$

From equations (8) and (9) we have

$$\nabla^2 \Psi + \frac{8\pi^2 m}{h^2} (E - V) \Psi = 0 \dots (10)$$

Equation (10) is Schrödinger equation which describes the behavior of electron in an atom.

◆ **Physical significance of Ψ and Ψ^2 :**

The function ‘ Ψ ’ represents the amplitude of vibration of matter wave associated with electron.

In classical theory of electromagnetic radiation, the square of amplitude is proportional to the intensity of light. A very similar concept was suggested by Barn in quantum mechanics according to which the square of function ‘ Ψ ’ at any point is proportional to the probability of finding the system at the point This definition of probability is in agreement with the uncertainty principle as one cannot talk about the precise position of subatomic particles ‘ Ψ ’ may be real or imaginary. Since the probability of finding a material particle at a given point in space has to be real, the term Ψ^2 has to be replaced by $\Psi^* \Psi$, when Ψ^* is the complex conjugate of Ψ . The complex conjugate can be obtained by replacing

$i(\sqrt{-1})$ by $-i$.

The probability of finding the particular system in small in space is proportional to

$$\Psi^* \Psi \, dx \, dy \, dz.$$

Integration over the whose of the configuration space gives a quantity which is proportional to the total probability of system

$$\int \Psi^* \Psi \, dx \, dy \, dz = N$$

$$\text{or } \frac{1}{N} \int \Psi^* \Psi \, dx \, dy \, dz = 1$$

$$\text{or } \int \left(\frac{1}{N^{1/2}} \Psi^* \right) \left(\frac{1}{N^{1/2}} \Psi \right) \, dx \, dy \, dz = 1$$

The factor is known as normalisation constant which is independent of the co-ordinate x , y and z .

The function $\frac{1}{N^{1/2}} \Psi$ is known as the normalisation

function.

Example Based on

Schrodinger wave theory

✎ **Example. 27**

The wave-mechanical model of atom is based upon

- (A) de Broglie concept of dual character of matter
- (B) Heisenberg’s uncertainty principle
- (C) Schrödinger wave equation
- (D) all the above three

Solution. (D)

✎ **Example. 28**

An orbital is correctly described by :

- (A) ψ^2 (B) ψ
- (C) $|\psi^2| \psi$ (D) None of these

Solution. (A)

18. QUANTUM NUMBERS

- (a) The measurement scale by which the orbitals are distinguished, can be represented by sets of numbers called as quantum number.
- (b) It is a very important number to specify and display to complete information about size, shape and orientation of the orbital. These are principle, azimuthal and magnetic quantum number, which follows directly from solution of Schrödinger wave equation.
- (c) Except of these quantum numbers, one additional quantum number designated as spin quantum number, which specify the spin of electron in an orbital.
- (d) Each orbital in an atom is specified by a set of three quantum numbers and each electron is designated by a set of four quantum numbers.

These quantum numbers are as follows :

◆ **Principal Quantum Number (n) :**

- (a) It was proposed by Bohr and denoted by 'n'.
- (b) It determines the average distance between electron and nucleus, means it is denoted the size of atom.
- (c) It determine the energy of the electron in an orbit where electron is present.
- (d) The maximum number of an electron in an orbit represented by this quantum number as $2n^2$.
- (e) It gives the information of orbit K, L, M, N,
- (f) The value of energy increases with the increasing value of n.
- (g) It represents the major energy shell from which the electron belongs.
- (h) An orbital momentum of any orbit = $\frac{nh}{2\pi}$

◆ **Azimuthal quantum number or angular quantum number (ℓ) :**

- (a) It was proposed by sommerfield and denoted by ' ℓ '.
- (b) It determines the number of subshells or sublevels to which the electron belongs.
- (c) It tells about the shape of subshells.
- (d) It also expresses the energies of subshells $s < p < d < f$ (Increasing energy).
- (e) The value of $\ell = (n - 1)$ always where 'n' is the number of principle shell.
- (f) Value of ℓ = 0 1 2 3 ----(n-1)
Name of subshell = s p d f
Shape of subshell = spherical Dumbbell Double dumbbell Complex
- (g) It represent the orbital angular momentum, which is equal to $\frac{h}{2\pi}\sqrt{\ell(\ell+1)}$.
- (h) The number of electrons in subshell = $2(2\ell + 1)$.
- (i) For a given value of 'n' the total value of ' ℓ ' is always equal to the value of 'n'.
- (j) The energy of any electron is depend on the value of n & ℓ because total energy = $(n + \ell)$. The electron enters in that sub orbit whose $(n + \ell)$ value or the value of energy is less.

◆ **Magnetic quantum number (m) :**

- (a) It was proposed by Linde and denoted by 'm'.
- (b) It gives the number of permitted orientation of subshells.
- (c) The value of m varies from $-\ell$ to $+\ell$ through zero.
- (d) It tells about the splitting of spectral lines in the magnetic field i.e. this quantum number proved the Zeeman effect.
- (e) For a given value of 'n' the total value of 'm' is equal to n^2 .
- (f) For a given value of ' ℓ ' the total value of 'm' is equal to $(2\ell + 1)$.
- (g) *Degenerate orbitals* - Orbitals having the same energy are known as degenerate orbitals.
e.g. for P subshell $P_x P_y P_z$
- (h) The number of degenerate orbitals of s subshell = 0.

◆ **Spin quantum number (s) :**

- (a) It was proposed by **Goldschmidt & Uhlenbeck** and denoted by the symbol of 's'.

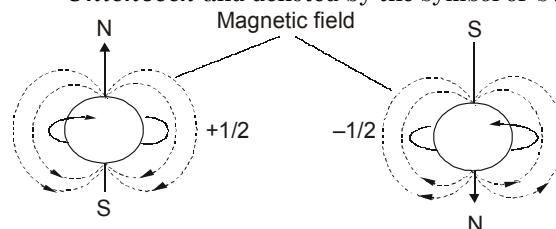

- (b) The value of 's' is $+\frac{1}{2}$ & $-\frac{1}{2}$, Which is signified the spin or rotation or direction of electron on it's axis during the movement.
- (c) The spin may be clockwise & anticlockwise.
- (d) It represents the value of spin angular momentum is equal to $\frac{h}{2\pi}\sqrt{s(s+1)}$.
- (e) Maximum spin of an atom = $\frac{1}{2} \times$ number of unpaired electron.

◆ **Relation between various quantum numbers :**

Energy level	Principal quantum number "n"	Total number of energy sub levels and their azimuthal quantum number "l"	Magnetic quantum number "m"	Spin quantum number "s"	Designation of orbital	Total number of electrons
K	1	0	0	$\pm \frac{1}{2}$	1s	2
L	2	0	0	$\pm \frac{1}{2}$	2s	2
		1	-1	$\pm \frac{1}{2}$	2 p _x	
			0	$\pm \frac{1}{2}$	2 p _z	6
			+1	$\pm \frac{1}{2}$	2 p _y	
M	3	0	0	$\pm \frac{1}{2}$	3s	2
		1	-1	$\pm \frac{1}{2}$	3 p _x	
			0	$\pm \frac{1}{2}$	3 p _z	6
			+1	$\pm \frac{1}{2}$	3 p _y	
		2	-2	$\pm \frac{1}{2}$	3 d _{x²-y²}	
			-1	$\pm \frac{1}{2}$	3 d _{yz}	10
			0	$\pm \frac{1}{2}$	3 d _{z²}	
			+1	$\pm \frac{1}{2}$	3 d _{zx}	
			+2	$\pm \frac{1}{2}$	3 d _{xy}	

◆ **Selection rules :**

The spectra of atoms are obtained when electron is transferred from one orbital to other.

According to quantum mechanical model of atom electronic transition obey certain selection rules. These are -

- (a) 'n' may change by any integer i.e. $\Delta n = \text{any value}$
 (b) ℓ must change by ± 1 i.e. $\Delta \ell = \pm 1$ and 'm' may change by ± 1 or not at all. $\Delta m = 0, \pm 1$

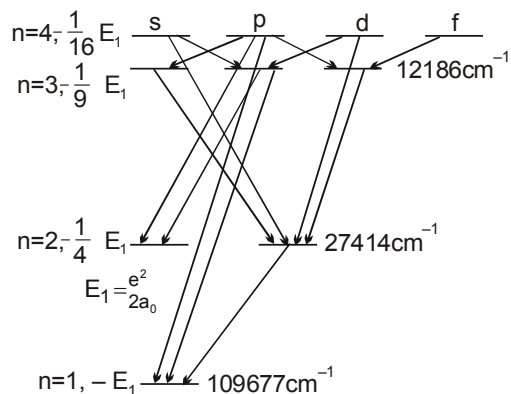

◆ **For example :**

If an electron changes its principle quantum number from $n = 2$ to $n = 1$, It must go from a state of $\ell = 1$ to $\ell = 0$ i.e. the transition $1s \leftarrow 2p$ is allowed. The transition $1s \leftarrow 2s$ where $\ell = 0$ is forbidden. A few other possible transitions in the hydrogen atom are shown in figure above.

19. SHAPE OF ORBITALS

◆ **Orbital :**

Orbital is the three dimensional region around the nucleus where there is a maximum tendency of finding an electron of definite energy

◆ **Shape of 's' orbital :**

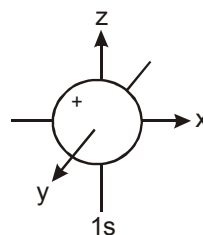

- (a) For 's' orbital $\ell = 0$ & $m = 0$ so 's' orbital have only one unidirectional orientation i.e. the probability of finding the electron is same in all directions.
 (b) The size and energy of 's' orbital with increasing 'n' will be $1s < 2s < 3s < 4s$.
 (c) It does not consist any directional property.

◆ **Shape of 'p' orbitals :**

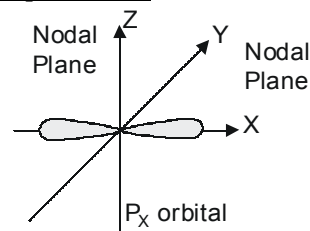

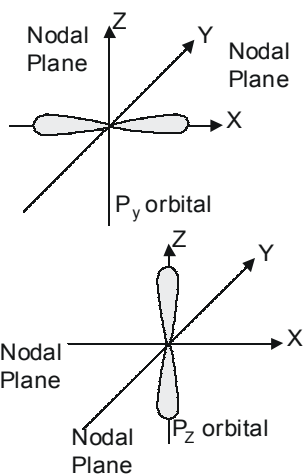

- (a) For 'p' orbital $\ell = 1$ & $m = +1, 0, -1$ means there are three 'p' orbitals, which is symbolised as p_x, p_y, p_z .
- (b) Shape of 'p' orbital is dumbbell in which the two lobes on opposite side separated by the nodal plane.
- (c) p-orbital has directional properties.

◆ **Shape of d-orbital :**

- (a) For the 'd' orbital $\ell = 2$ then the values of 'm' are $-2, -1, 0, +1, +2$. It shows that the 'd' orbitals are five as $d_{xy}, d_{yz}, d_{zx}, d_{x^2-y^2}, d_{z^2}$
- (b) Each 'd' orbital identical in shape, size and energy.
- (c) The 'd' orbital is bidumb-belled.
- (d) It has directional properties.

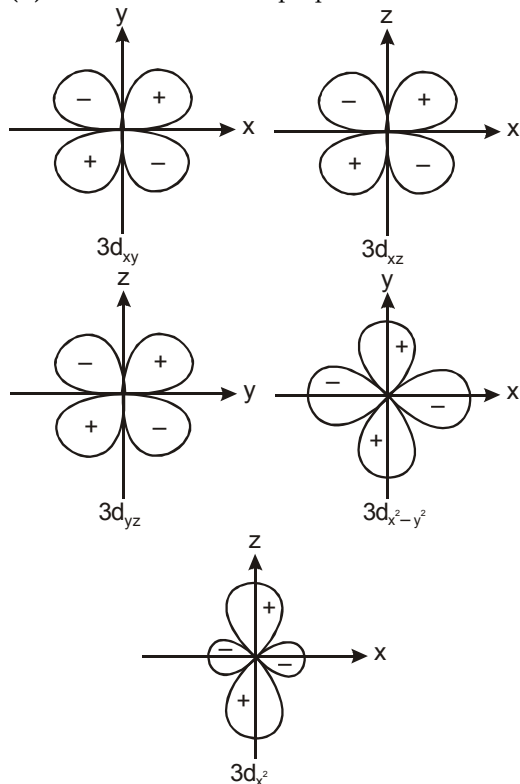

* Only for Target Course students

Example Based on

Quantum numbers and shape of orbitals

✎ **Example. 29**

The maximum number of atomic orbitals associated with a principal quantum number 5 is

- (A) 9 (B) 12
(C) 16 (D) 25

Solution. (D)

The number of orbitals in a principle shell is $n^2 = 5^2 = 25$.

✎ **Example. 30**

Beryllium's fourth electron will have the four quantum numbers :

	n	ℓ	m	s
(A)	1	0	0	1/2
(B)	1	1	1	1/2
(C)	2	0	0	-1/2
(D)	2	1	0	+1/2

Solution. (C) it is $2s^2$

✎ **Example. 31**

To give designation to an orbital, we need

- (A) Principal and azimuthal quantum number
(B) Principal and magnetic quantum number
(C) Azimuthal and magnetic quantum number
(D) Principal, azimuthal and magnetic quantum numbers.

Solution. (D)

Quantum numbers are signature of an electron of particular orbital

✎ **Example. 32**

- (a) An electron is in 5f-orbital. What possible values of quantum numbers n, l, m and s can it have ?
- (b) What designation is given to an orbital having (i) $n = 2, l = 1$ and (ii) $n = 3, l = 0$?

Solution. (a)

For an electron in 5f - orbital, quantum number are : $n = 5, \ell = 3$; $m = -3, -2, -1, 0, +1, +2, +3$ and $s =$ either $+1/2$ or $-1/2$

- (b) (i) 2p, (ii) 3s.

20. ENERGY LEVEL DIAGRAM

- (a) The representation of relative energy levels of various atomic orbital is made in the terms of energy level diagrams.
- (b) **One electron system :** In this system electron is in $1s^2$ level and all orbital of same principal quantum number have same energy, which is independent of (ℓ). In this system ℓ only determines the shape of orbital.

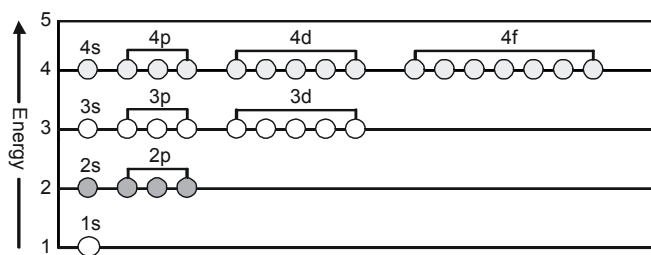

(c) **Multiple electron system :**
The energy levels of such system not only depend upon the nuclear charge but also upon the another electron present in them -

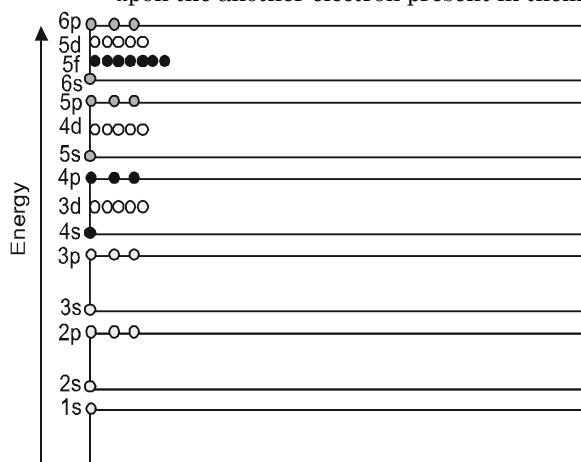
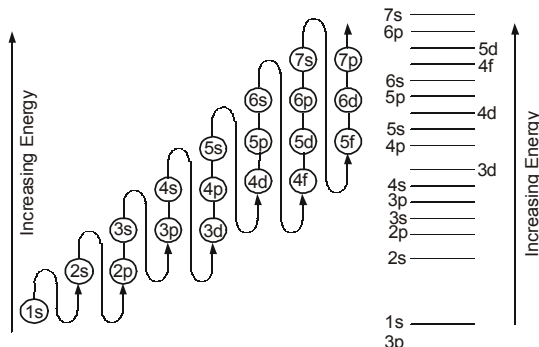

Diagram of multielectron atoms reveals the following points

- (d) As the distance of the shell increases from the nucleus, the energy level increases. For example energy level of $2 > 1$.
- (e) The different sub shells have different energy levels who have possess definite energy levels. For a definite shell, the subshell having higher value of ℓ possesses higher energy level. For example in 4th shell.
Energy level order
 $4f > 4d > 4p > 4s$
 $\ell = 3 \quad \ell = 2 \quad \ell = 1 \quad \ell = 0$



- (f) The relative energy of sub shells of different energy shell can be explained in terms of the $(n + \ell)$ rule.
The subshell with lower values of $(n + \ell)$ possess lower energy level.

$$\text{For } 3d \quad n = 3 \quad \ell = 2 \quad \therefore n + \ell = 5$$

$$\text{For } 4s \quad n = 4 \quad \ell = 0 \quad n + \ell = 4$$

- (g) If the value of $(n + \ell)$ for two orbitals is same, one with lower values of 'n' possess lower energy level.

21. ELECTRONIC CONFIGURATION

The distribution of electrons in different orbitals is known as electronic configuration of the atoms. Filling up of orbitals in the ground state of atom is governed by the following rules :

◆ Aufbau Principle :

- (a) It is a German word, meaning 'building up'
- (b) According to this principle, "In the ground state, the atomic orbitals are filled in order of increasing energies". i.e. in the ground state the electrons occupy the lowest orbitals available to them.
- (c) The sequence of filling of e^- we have already discussed in previous article
- (d) In fact the energy of an orbital is determined by the quantum number n and ℓ with the help of $(n + \ell)$ rule or Bohr Bury rule
- (e) According to this rule
- (i) Lower the value of $(n + \ell)$, lower is the energy of the orbital and such an orbital will be filled up first
- (ii) When two orbitals have same value of $(n + \ell)$ the orbital having lower value of "n" has lower energy and such an orbital will be filled up first.

◆ Pauli's Exclusion Principle :

- (a) According to this principle, " No two electrons in an atom can have all the four quantum numbers n, ℓ, m and s identical.
- (b) In an atom, any two electrons may have three quantum numbers identical but fourth quantum number must be different.
- (c) Since this principle excludes certain possible combinations of quantum numbers for any two electrons in an atom, it was given the name exclusion principle. Its results are as follows
- (i) The maximum capacity of a main energy shell is equal to $2n^2$ electron
- (ii) The maximum capacity of a subshell is equal to $2(2\ell + 1)$ electrons
- (iii) Number of sub-shells in a main energy shell is equal to the value of n
- (iv) Number of orbitals in a main energy shell is equal to n^2
- (v) one orbital cannot have more than two electrons



Correct

Incorrect

◆ **Hund's Rule of Maximum Multiplicity :**

- (a) This rule governs the filling up of degenerate orbitals of the same sub-shell
- (b) According to this rule "Electron filling will not take place in orbitals of same energy untill all the available orbital of a given subshell contain one electron each with parallel spin."
- (c) This implies that electron pairing begins with fourth, sixth and eighth electron in p, d and f orbitals of the same sub-shell respectively.
- (d) The reason behind this rule is related to repulsion between identical charged electron present in the same orbital
- (e) They can minimise the repulsive forces between them serves by occupying different orbitals.
- (f) Moreover, according to this principle, the e^- entering the different orbitals of subshell have parallel spins. This keeps them farther apart and lowers the energy through electron exchange or resonance.
- (g) The term maximum multiplicity means that the total spin of unpaired e^- is maximum in case of correct filling of orbitals as per this rule.

22. EXTRA STABILITY OF HALF FILLED AND COMPLETELY FILLED SUB-SHELLS

Half-filled and completely filled sub-shells have extra stability due to the following reasons.

◆ **Symmetry of orbitals :**

- (a) It is a well known fact that symmetry leads to stability.
- (b) Thus, if the shift of an electron from one orbital to another orbital differing slightly in energy results in the symmetrical electronic configuration. it becomes more stable.
- (c) For example p^3 , d^5 , f^7 configurations are more stable than their near ones

◆ **Exchange Energy :**

- (a) The e^- in various subshells can exchange their positions, since e^- in the same subshell have equal energies.
- (b) The energy is released during the exchange process with in the same subshell.

- (c) In case of half filled and completely filled orbitals, the exchange energy is maximum and is greater than the loss of orbital energy due to the transfer of electron from a higher to a lower sublevel e.g. from 4s to 3d orbitals in case of Cu and Cr
- (d) The greater the number of possible exchanges between the electrons of parallel spins present in the degenerate orbitals, the higher would be the amount of energy released and more will be the stability
- (e) Let us count the number of exchange that are possible in d^4 and d^5 configuration among electrons with parallel spins :

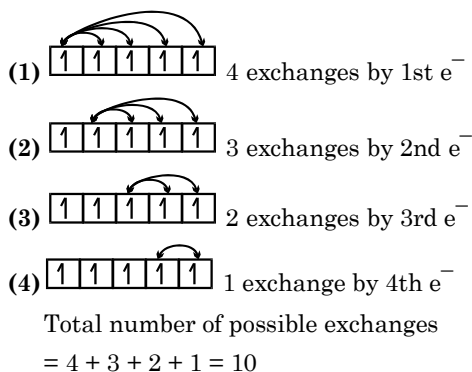
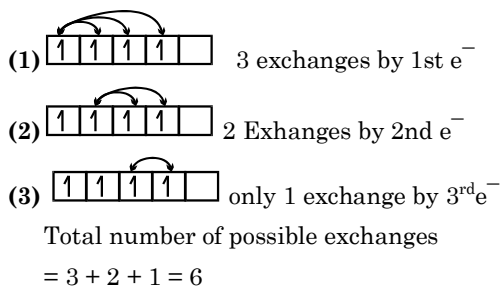

23. ELECTRONIC CONFIGURATION OF ELEMENTS

Element	At. No.	1s	2s	2p	3s	3p	3d	4s	4p	4d	4f	5s	5p	6d	5f
H	1	1													
He	2	2													
Li	3	2	1												
Be	4	2	2												
B	5	2	2	1											
C	6	2	2	2											
N	7	2	2	3											
O	8	2	2	4											
F	9	2	2	5											
Ne	10	2	2	6											
Na	11	2	2	6	1										
Mg	12	2	2	6	2										
Al	13	2	2	6	2	1									
Si	14	2	2	6	2	2									
P	15	2	2	6	2	3									
S	16	2	2	6	2	4									
Cl	17	2	2	6	2	5									
Ar	18	2	2	6	2	6									
K	19	2	2	6	2	6		1							
Ca	20	2	2	6	2	6		2							
Sc	21	2	2	6	2	6	1	2							
Ti	22	2	2	6	2	6	2	2							
V	23	2	2	6	2	6	3	2							
*Cr	24	2	2	6	2	6	5	1							
Mn	25	2	2	6	2	6	5	2							
Fe	26	2	2	6	2	6	6	2							
Co	27	2	2	6	2	6	7	2							
Ni	28	2	2	6	2	6	8	2							
*Cu	29	2	2	6	2	6	10	2							
Zn	30	2	2	6	2	6	10	1							
Ga	31	2	2	6	2	6	10	2	1						
Ge	32	2	2	6	2	6	10	2	2						
As	33	2	2	6	2	6	10	2	3						
Se	34	2	2	6	2	6	10	2	4						
Br	35	2	2	6	2	6	10	2	5						
Kr	36	2	2	6	2	6	10	2	6						
Rb	37	2	2	6	2	6	10	2	6		1				
Sr	38	2	2	6	2	6	10	2	6		2				
Y	39	2	2	6	2	6	10	2	6	1	2				
Zr	40	2	2	6	2	6	10	2	6	2	2				
*Nb	41	2	2	6	2	6	10	2	6	4	1				
*Mo	42	2	2	6	2	6	10	2	6	5	1				
Tc	43	2	2	6	2	6	10	2	6	5	2				
*Ru	44	2	2	6	2	6	10	2	6	7	1				
*Rh	45	2	2	6	2	6	10	2	6	8	1				
*Pd	46	2	2	6	2	6	10	2	6	10					
*Ag	47	2	2	6	2	6	10	2	6	10	1				
Cd	48	2	2	6	2	6	10	2	6	10	2				
n	49	2	2	6	2	6	10	2	6	10	2	1			
Sn	50	2	2	6	2	6	10	2	6	10	2	2			
Sb	51	2	2	6	2	6	10	2	6	10	2	3			
Te	52	2	2	6	2	6	10	2	6	10	2	4			
I	53	2	2	6	2	6	10	2	6	10	2	5			
Xe	54	2	2	6	2	6	10	2	6	10	2	6			

Element	At. No.	K	L	M	4s	4p	4d	4f	5s	5p	5d	5f	6s	6p	6d	6f	7s
Cs	55	2	8	18	2	6	10		2	6			1				
Ba	56	2	8	18	2	6	10		2	6			2				
*La	57	2	8	18	2	6	10		2	6	1		2				
Ce	58	2	8	18	2	6	10	2	2	6			2				
Pr	59	2	8	18	2	6	10	3	2	6			2				
Nd	60	2	8	18	2	6	10	4	2	6			2				
Pm	61	2	8	18	2	6	10	5	2	6			2				
Sm	62	2	8	18	2	6	10	6	2	6			2				
Eu	63	2	8	18	2	6	10	7	2	6			2				
*Gd	64	2	8	18	2	6	10	7	2	6	1		2				
Tb	65	2	8	18	2	6	10	9	2	6			2				
Dy	66	2	8	18	2	6	10	10	2	6			2				
Ho	67	2	8	18	2	6	10	11	2	6			2				
Er	68	2	8	18	2	6	10	12	2	6			2				
Tm	69	2	8	18	2	6	10	13	2	6			2				
Yb	70	2	8	18	2	6	10	14	2	6			2				
Lu	71	2	8	18	2	6	10	14	2	6	1		2				
Hf	72	2	8	18	2	6	10	14	2	6	2		2				
Ta	73	2	8	18	2	6	10	14	2	6	3		2				
W	74	2	8	18	2	6	10	14	2	6	4		2				
Re	75	2	8	18	2	6	10	14	2	6	5		2				
Os	76	2	8	18	2	6	10	14	2	6	6		2				
Ir	77	2	8	18	2	6	10	14	2	6	7		2				
*Pt	78	2	8	18	32	2	6	9		1			1				
*Au	79	2	8	18	32	2	6	10		1			1				
Hg	80	2	8	18	32	2	6	10		2			2				
Tl	81	2	8	18	32	2	6	10		2	1		2	1			
Pb	82	2	8	18	32	2	6	10		2	2		2	2			
Bi	83	2	8	18	32	2	6	10		2	3		2	3			
Po	84	2	8	18	32	2	6	10		2	4		2	4			
At	85	2	8	18	32	2	6	10		2	5		2	5			
Rn	86	2	8	18	32	2	6	10		2	6		2	6			
Fr	87	2	8	18	32	2	6	10		2	6		2	6			
Ra	88	2	8	18	32	2	6	10		2	6		2	6			1
*Ac	89	2	8	18	32	2	6	10		2	6		2	6			2
*Th	90	2	8	18	32	2	6	10	0	2	6	0	2	6	1		2
*Pa	91	2	8	18	32	2	6	10	2	2	6	2	2	6	2		2
*U	92	2	8	18	32	2	6	10	3	2	6	3	2	6	1		2
Np	93	2	8	18	32	2	6	10	5	2	6	5	2	6	1		2
Pu	94	2	8	18	32	2	6	10	6	2	6	6	2	6	1		2
Am	95	2	8	18	32	2	6	10	7	2	6	7	2	6			2
*Cm	96	2	8	18	32	2	6	10	7	2	6	7	2	6			2
*Bk	97	2	8	18	32	2	6	10	8	2	6	8	2	6	1		2
Cf	98	2	8	18	32	2	6	10	10	2	6	10	2	6	1		2
Fs	99	2	8	18	32	2	6	10	11	2	6	11	2	6			2
Fm	100	2	8	18	32	2	6	10	12	2	6	12	2	6			2
Md	101	2	8	18	32	2	6	10	13	2	6	13	2	6			2
No	102	2	8	18	32	2	6	10	14	2	6	14	2	6			2
*Lw	103	2	8	18	32	2	6	10	14	2	6	14	2	6			2
Ku	104	2	8	18	32	2	6	10	14	2	6	14	2	6	1		2
Ha	105	2	8	18	32	2	6	10	14	2	6	14	2	6	2		2

Example Based on**Aufbau rule and e^- configuration****Example. 33**

For a given value of n (principal quantum number), the energy of different subshells can be arranged in the order of :

- (A) $f > d > p > s$ (B) $s > p < d > f$
 (C) $f > p > d > s$ (D) $s > f > p > d$

Solution. (A)

It is the rule

Example. 34

Correct set of four quantum numbers for the outermost electron of rubidium ($Z = 37$) is :

- (A) 5, 0, 0, $1/2$ (B) 5, 1, 0, $1/2$
 (C) 5, 1, 1, $1/2$ (D) 6, 0, 0, $1/2$

Solution. (A)

Its configuration is $5s^1$

Example. 35

The order of increasing energies of the orbitals follows :

- (A) 3s, 3p, 4s, 3d, 4p (B) 3s, 3p, 3d, 4s, 4p
 (C) 3s, 3p, 4s, 4p, 3d (D) 3s, 3p, 3d, 4p, 4s

Solution. (A)

Follow $(n + l)$ rule

Example. 36

The total spin resulting from a d^7 configuration is

- (A) $3/2$ (B) $1/2$
 (C) 2 (D) 1.

Solution. (A)

For d^7 , three unpaired electrons, $spin = 3 \times \frac{1}{2} = \frac{3}{2}$

Example. 37

Calculate total spin, magnetic for the atoms having at no. 7, 24, 34 and 36.

Solution.

The electronic configuration are

${}_7\text{N} : 1s^2, 2s^2 2p^3$ Unpaired electron = 3

${}_{24}\text{Cr} : 1s^2, 2s^2 2p^6, 3s^2 3p^6 3d^5, 4s^1$ unpaired electron = 6

${}_{34}\text{Se} : 1s^2, 2s^2 2p^6, 3s^2 3p^6 3d^{10}, 4s^2 4p^4$ unpaired electron = 2

${}_{36}\text{Kr} : 1s^2, 2s^2 2p^6, 3s^2 3p^6 3d^{10}, 4s^2 4p^6$ unpaired electron = 0

\therefore Total spin for an atom = $\pm 1/2 \times$ no. of unpaired electron

For ${}_7\text{N}$, it is = $\pm 3/2$; For ${}_{24}\text{Cr}$, it is = ± 3

For ${}_{34}\text{Se}$, it is = ± 1 ; For ${}_{36}\text{Kr}$, it is = 0

Also magnetic moment = $\sqrt{[n(n+2)]}$ Bohr magneton

For ${}_7\text{N}$, it is = $\sqrt{(15)}$; For ${}_{24}\text{Cr}$, it is = $\sqrt{(48)}$

For ${}_{34}\text{Se}$, it is = $\sqrt{(8)}$

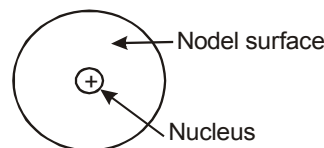
24. SOME IMPORTANT DEFINITIONS**Nodal Surface :**

- (a) The place find in between two 's' orbitals where the value of electron density is equal to zero called **Nodal Surface**
- (b) The number of Nodal surfaces in an atom = $(n - 1)$, where 'n' is the number of total shell in an atom.

Nodal Plane :

The place for 'p' and 'd' orbitals where the value of electron density is equal to zero called

Nodal Plane.

For $p_x = yz$

$p_y = xz$

$p_z = xy$

For $d_{xy} = yz, zx$

$d_{yz} = xy, xz$

$d_{x^2-y^2} = 0$

$d_{zx} = xy, yz$

$d_{z^2} = 0$

Nodal Point :

The nucleus of an atom called **Nodal Point**.

Isodiapheres :

The elements which have same value of $(n - p)$ is called **Isodiapheres**.

eg. ${}_7\text{N}^{14} {}_8\text{O}^{16}$

Values of $(n - p)$ 0 0

Isotone :

Elements which contain same no. of neutron is called **Isotone**.

eg. ${}_{14}\text{Si}^{30}$ ${}_{15}\text{P}^{31}$ ${}_{16}\text{S}^{32}$

number of neutrons 16 16 16

Isotopes :

- (a) First proposed by soddy.
- (b) The isotopes have same atomic number but different atomic weight.
- (c) They have same chemical properties because they have same atomic number.
- (d) They have different physical properties because they have different atomic masses.

eg. ${}_1\text{H}^1$ ${}_1\text{H}^2$ ${}_1\text{H}^3$

Protonium deuterium Tritium

Z = 1 1 1

A = 1 2 3

◆ **Isobar :**

The two different atoms which have same atomic masses but different atomic number is called as **Isobar**.

eg.	${}_{18}\text{Ar}^{40}$	${}_{19}\text{K}^{40}$	${}_{20}\text{Ca}^{40}$
Atomic mass	40	40	40
Atomic number	18	19	20

◆ **Isomorphous :**

The two different type of compound which contain same crystalline structure called **Isomorphous** and this property called **Isomorphism**.

- eg. (a) $\text{FeSO}_4 \cdot 7\text{H}_2\text{O}$ (Green vitriol)
Hepta hydrate Ferrous sulphate
(b) $\text{ZnSO}_4 \cdot 7\text{H}_2\text{O}$ (White vitriol)
Hepta hydrate Zinc Sulphate

◆ **Isomers :**

Species which have same molecular formula but different structural formula is called Isomer and this type of property is called Isomerism.

eg. $\text{C}_2\text{H}_6\text{O} \rightarrow \text{C}_2\text{H}_5\text{OH} \text{ \& \ } \text{CH}_3\text{-O-CH}_3$

◆ **Isoelectronic :**

Ion or atom or molecule or species which have the same number of electron is called Isoelectronic species.

eg.	${}_{17}\text{Cl}^-$	${}_{18}\text{Ar}$	${}_{19}\text{K}^+$	${}_{20}\text{Ca}^{+2}$
No. of electron	18	18	18	18
eg.	$\text{CN}^- \text{ \& \ } \text{CO}$			
No. of electron	14	14		

◆ **Isosters :**

Substance which have same number of electron and atoms called Isosters.

eg.	CO_2	N_2O
No. of electron	22	22

◆ **Kernel :**

Orbit which present after removing the outer most orbit of that atom is called kernel and electrons which is present that orbit called kernel electrons.

eg. $\text{Mg} = 1s^2 2s^2 2p^6, 3s^2$
Total kernel electron = $2 + 2 + 6 = 10$

◆ **Core :**

(a) The outer most shell of an any atom called **Core** and the number of electron present of that shell is called **Core electron**.

eg. $\text{Cl} = 1s^2 2s^2 2p^6 3s^2 3p^5$
Core electron = $2 + 5 = 7$

(b) If the core is unstable for an atom then that atom shows variable valency.

NOTE

When an electron is in the stationary state then the value of magnetic field for that electron is equal to zero.

◆ **Promotion :**

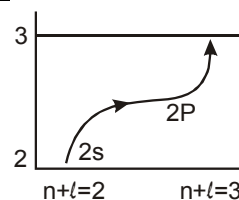

The transfer of electron between subshells in an orbit is called promotion. While the transfer of one energy level to another is called transition. After the completion of promotion the transition process is occurred.

eg. First promotion of an electron is 2s ($n + \ell = 2 + 0 = 2$) to 2p ($n + \ell = 2 + 1 = 3$) sub-shell and their transition to 2nd orbit to 3rd orbit or 2p to 3s.

◆ **Radial and angular functions :**

Schrodinger wave equation can be written in terms of polar coordinates as

$$\frac{1}{r^2} \frac{\partial}{\partial r} \left(r^2 \frac{\partial \Psi}{\partial r} \right) + \frac{1}{r^2 \sin^2 \theta} \frac{\partial^2 \Psi}{\partial \phi^2} + \frac{1}{r^2 \sin \theta} \frac{\partial}{\partial \theta} \left(\sin \theta \frac{\partial \Psi}{\partial \theta} \right) + \frac{8\pi^2 m}{h^2} (E - V) \Psi = 0$$

The solution of this is of the form

$$y = R(r) \cdot \Theta(\theta) \cdot \Phi(\phi) \quad \dots (i)$$

$R(r)$ is a function that depends on the distance from the nucleus, which in turn depends on the quantum numbers n and ℓ .

q (q) is a function of q , which depends on the quantum number ℓ and m

f (f) is a function f , which depends only on the quantum number m

Equation (i) may be rewritten as

$$y = R(r)_{nl} \cdot A_{ml}$$

This splits the wave function into two parts which can be solved separately :

- (i) $R(r)$ the radial function which depends on the quantum number n and ℓ .
- (ii) A_{ml} the total angular wave function, which depends on the quantum numbers m and ℓ .

The radial function R has no physical meaning but R^2 gives the probability of finding the electron in a small volume dv near the point at which R is measured. For a given value of r the number of small volumes is $4\pi r^2$, so the probability of the electron being at a distance r from the nucleus is $4\pi r^2 R^2$. This is called as radial distribution function for hydrogen its graph are as follows.

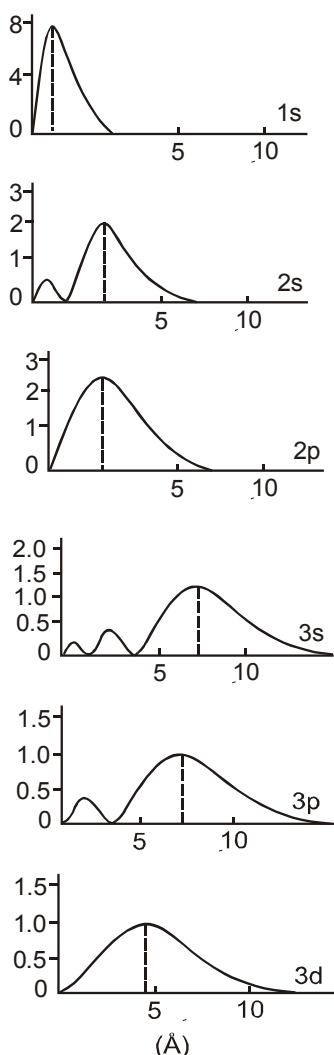

Radial distribution functions for various orbitals in the hydrogen atom.

The angular function A depends only on the direction and is independent of the distance from the nucleus (r). Thus A^2 is the probability of finding an electron at a given direction θ . This is plotted as polar diagram as shown below

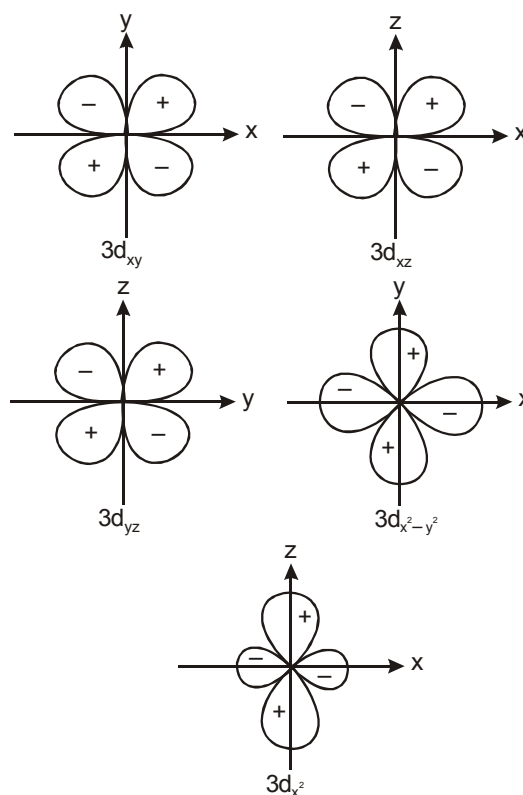
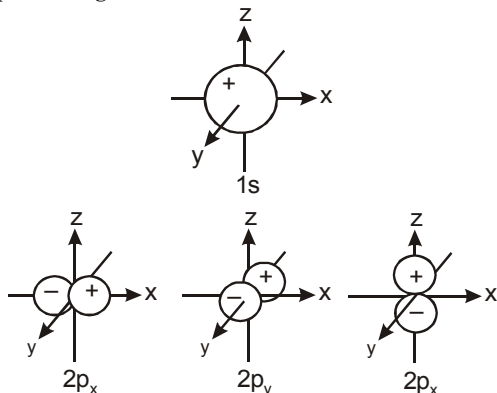

Boundary surface for the angular part of the wave function

$A(\theta, \phi)$ for the 1s, 2p and 3d orbitals for a hydrogen atom shown as polar diagrams .

these polar diagrams do not represent the total wave function ψ but only the angular part of the wave function. These diagrams are commonly used to illustrate the overlap of orbitals giving bonding between atoms. Basically for bonding. Like signs must overlap.



Points to Remember

1. The wave character is of no significance in case of large objects like cricket ball, a car, a train etc.
2. The most important applications of de-Broglie concept is in the construction of electron microscope and the study of surface structure of solids by electron diffraction.
3. Smaller the wavelength of the electron wave, more is the resolving power of the electron microscope
4. Uncertainty in measurement is not due to lack of any experimental technique but due to nature of subatomic particle itself
5. Shapes of orbitals are functional representation of mathematical solutions of Schrodinger equations. They do not represent any picture of electric charge or matter.

SOLVED EXAMPLES

Ex.1 The ratio of the wave lengths of last lines of Balmer and Lyman series is -

- (A) 4 : 1 (B) 27 : 5
(C) 3 : 1 (D) 9 : 4

Sol.(A) The wave length of a spectral line may be given by the following expression

$$\frac{1}{\lambda} = R \left(\frac{1}{n_1^2} - \frac{1}{n_2^2} \right)$$

For Lyman series $n_1 = 1$, For Balmer series $n_1 = 2$

For the last line in both the series $n_2 = \infty$

For Lyman series

$$\frac{1}{\lambda_L} = R \left(1 - \frac{1}{\infty} \right) = R (1 - 0) = R$$

$$\lambda_L = \frac{1}{R}$$

For Balmer series

$$\frac{1}{\lambda_B} = R \left(\frac{1}{4} - \frac{1}{\infty} \right) = \frac{R}{4}$$

$$\lambda_B = \frac{4}{R}$$

$$\frac{\lambda_B}{\lambda_L} = \frac{4}{R} \times \frac{R}{1} = \frac{4}{1}$$

Ex.2 Consider an electron which is brought close to the nucleus of the atom from an infinite distance, the energy of the electron-nucleus system -

- (A) increases (B) decreases
(C) remains same (D) none of these

Sol.(B) The energy (P.E.) of the electron is a function of its distance from the nucleus and is given by Coulomb's law as

$$\text{P.E.} = - \frac{e^2}{r}$$

Total energy = K.E. + P.E.

$$= \frac{1}{2} mv^2 - \frac{e^2}{r} \left(\frac{1}{2} mv^2 = \frac{e^2}{2r} \right) = - \frac{e^2}{2r}$$

as 'r' decreases energy will go on decreasing.

Ex.3 Using arbitrary energy units we can calculate that 864 arbitrary units (a.u.) are required to transfer an electron in hydrogen atom from the most stable Bohr's orbit to the largest distance from the nucleus -

$n = \infty$ $E = 0$ Arbitrary units

$n = 4$

$n = 3$

$n = 2$

$n = 1$

$E = -864$ Arbitrary units

The energy required to transfer the electron from third Bohr's orbit to the orbit $n = \infty$ will be -

- (A) 96 Arbitrary units
(B) 192 Arbitrary units
(C) 288 Arbitrary units
(D) 384 Arbitrary units

Sol.(A) The energy of first Bohr's orbit of H-atom

$$= - \frac{2\pi^2 me^4}{h^2} = -864$$

The energy of third Bohr's orbit of H atom

$$= - \frac{2\pi^2 me^4}{h^2} \times \frac{1}{3^2} = -864 \times \frac{1}{9}$$

$= -96$ Arbitrary units

Energy required to separate the electron

$$= E_\infty - E_n$$

$$= 0 - (-96)$$

$$= 96 \text{ Arbitrary units}$$

Ex.4 In an electronic transition, the wavelength of a spectral line is inversely related to -

- (A) The nuclear charge of the atom
(B) The difference in energy levels
(C) The velocity of electron
(D) The number of orbitals involved in transition

Sol.(A)
$$\frac{1}{\lambda} = \frac{2\pi^2 me^4 Z^2}{ch^3 (4\pi\epsilon_0)^2} = \left[\frac{1}{n_1^2} - \frac{1}{n_2^2} \right]$$

$$\lambda \propto \frac{1}{Z^2}$$

Ex.5 The ratio of time periods in first and second orbits of hydrogen atom is -

- (A) 1 : 4 (B) 1 : 8 (C) 1 : 2 (D) 2 : 1

Sol.(B) Time period in first orbit (T_1) = $\frac{2\pi r_1}{v_1}$

Time period in second orbit (T_2) = $\frac{2\pi r_2}{v_2}$

$$\frac{T_1}{T_2} = \frac{2\pi r_1}{v_1} \times \frac{v_2}{2\pi r_2}$$

$$= \frac{r_1}{r_2} \times \frac{v_2}{v_1}$$

Velocity of electron in first orbit

$$= \frac{2.188 \times 10^8}{1} \text{ cm s}^{-1}$$

Velocity of electron in second orbit

$$= \frac{2.188 \times 10^8}{2} \text{ cm s}^{-1}$$

Radius of first orbit

$$= 0.528 \times 10^{-8} \text{ cm}$$

Radius of second orbit

$$= 0.528 \times 10^{-8} \times 4 \text{ cm}$$

$$\frac{T_1}{T_2} = \frac{0.528 \times 10^{-8}}{0.528 \times 10^{-8} \times 4} \times \frac{2.188 \times 10^{-8}}{2 \times 2.188 \times 10^{-8}} = \frac{1}{8}$$

- Ex.6** In a hydrogen atom, the largest amount of energy will be required in -
 (A) $n_2 \rightarrow n_3$ transition
 (B) $n_\infty \rightarrow n_1$ transition
 (C) $n_1 \rightarrow n_2$ transition
 (D) $n_3 \rightarrow n_5$ transition

Sol.(C) $E_n = \frac{2\pi^2 me^4}{n^2 h^2 (4\pi\epsilon_0)^2}$ and

$$\Delta E = -\frac{2\pi^2 me^4}{h^2 (4\pi\epsilon_0)^2} \left[\frac{1}{n_1^2} - \frac{1}{n_2^2} \right]$$

- Ex.7** The ion that is isoelectronic with CO is -
 (A) CN^- (B) O_2^+ (C) O_2^- (D) N_2^+

Sol.(A) $\text{CO } 6 + 8 = 14$
 $\text{CN}^- 6 + 7 + 1 = 14$
 $\text{O}_2^+ 8 \times 2 - 1 = 15$
 $\text{O}_2^- 8 \times 2 + 1 = 17$
 $\text{N}_2^+ 7 \times 2 - 1 = 13$

- Ex.8** Of the following, which of the statement(s) regarding Bohr theory is/are correct ?
 (A) Kinetic energy of an electron is half of the magnitude of its potential energy
 (B) Kinetic energy of an electron is negative of total energy of electron
 (C) Energy of electron decreases with increase in the value of principal quantum number
 (D) The ionization energy of H-atom in the first excited state is the negative of one fourth of the energy of an electron in the ground state

Sol.(A,B,D)

The energy of an electron in H-like atoms is given by

$$E = \text{K.E.} + \text{P.E.}$$

$$= \frac{1}{2} mv^2 - \frac{Ze^2}{(4\pi\epsilon_0)r}$$

From the stability of the circular motion of electron, we have

$$\frac{mv^2}{r} = \frac{Ze^2}{(4\pi\epsilon_0)r^2};$$

$$\text{Hence } E = \frac{1}{2} \frac{Ze^2}{(4\pi\epsilon_0)r} - \frac{Ze^2}{(4\pi\epsilon_0)r}$$

$$\text{or } E = -\frac{1}{2} \frac{Ze^2}{(4\pi\epsilon_0)r}$$

- Ex.9** An element with atomic mass Z consists of two isotopes of mass number $Z-1$ and $Z+2$. The percentage abundance of the heavier isotope is-

- (A) 0.25 (B) 33.3
 (C) 66.6 (D) 75

Sol.(B) $Z = \frac{(Z-1)x + (Z+2)(100-x)}{100}$

- Ex.10** Frequency ratio between violet (400 nm) and red (750 nm) radiations in the visible spectrum, is -

- (A) 8/15 (B) 4/15
 (C) 15/8 (D) None of these

Sol.(C) $v = \frac{c}{\lambda}$

For violet (400 nm) $v_1 = \frac{c}{400 \times 10^{-9}}$

For red (750 nm) $v_2 = \frac{c}{750 \times 10^{-9}}$

$$\frac{v_1}{v_2} = \frac{750}{400} = \frac{15}{8}$$

- Ex.11** The orbital angular momentum of an electron in 2s orbital is -

- (A) $+\frac{1}{2} \frac{h}{2\pi}$ (B) zero
 (C) $\frac{h}{2\pi}$ (D) $\sqrt{2} \frac{h}{2\pi}$

Sol.(B) orbital angular momentum = $\sqrt{\ell(\ell+1)} \frac{h}{2\pi}$

$$\sqrt{\ell(\ell+1)} = h \text{ for S-orbital } \ell = 0$$

So orbital angular momentum is zero.

- Ex.12** The sub-shell that comes after f-sub-shell is called g-sub-shell. The number of g-sub orbitals in g-sub-shell and the total number of orbitals in the principal orbital respectively are-

- (A) 10 and 25 (B) 9 and 25
 (C) 11 and 23 (D) 15 and 45

Sol.(B) For a g-subshell : $n = 5$ and $\ell = 4$

$$\text{Number of orbitals g-subshell} = (2\ell + 1) = 9$$

$$\text{Total number of orbitals in atom} = n^2 = (5)^2 = 25$$

- Ex.13** Two isotopes of Boron are found in the nature with atomic weights 10.01(I) and 11.01 (II). The atomic weight of natural Boron is 10.81. The percentage of (I) and (II) isotopes in it are respectively -

- (A) 20 and 80 (B) 10 and 90
 (C) 15 and 75 (D) 30 and 70

- Sol.(A)** Let $x\%$ of I (10.01) is mixed with II (11.01) and the atomic weight become 10.81. Then

$$\frac{(10.01)x + (11.01)(100-x)}{100} = 10.81$$

$$10.01x - 11.01 \times + 1101 = 10.81 \times 100$$

$$\text{or } -x = 1081 - 1101$$

$$\text{or } -x = -20$$

$$\therefore x = 20$$

$$\text{So ratio} = 20\% \text{ and } 100 - 20 = 80\%$$

Ex.14 For a d-electron, the orbital angular momentum is -

- (A) $\sqrt{6} h/2\pi$ (B) $\sqrt{2} h/2\pi$
 (C) $h/2\pi$ (D) $2.h/2\pi$

Sol.(A) Angular momentum L is given by

$$L = \sqrt{\ell(\ell+1)} \cdot \frac{h}{2\pi}$$

For d-orbital, $\ell = 2$, so

$$L = \sqrt{2(2+1)} \frac{h}{2\pi} = \sqrt{6} \frac{h}{2\pi}$$

Ex.15 The energy of the emitted photon when an electron in Be^{3+} ion returns from $n = 2$ level to ground state is -

- (A) $2.616 \times 10^{-17} \text{ J}$ (B) $26.16 \times 10^{-17} \text{ J}$
 (C) $216.6 \times 10^{-17} \text{ J}$ (D) $2616 \times 10^{-17} \text{ J}$

Sol.(A)
$$\frac{1}{\lambda} = RZ^2 \left(\frac{1}{n_1^2} - \frac{1}{n_2^2} \right)$$

Ex.16 Calculate the wave-number of lines having the frequency of 5×10^{16} cycles per sec -

Sol. Given $c = 3 \times 10^8 \text{ m/sec}$
 $v = 5 \times 10^{16} \text{ cycles/sec}$
 $= ?$

We know that

$$\bar{\nu} = \frac{v}{c} = \frac{5 \times 10^{16}}{3 \times 10^8} = 1.666 \times 10^8 \text{ m}^{-1}$$

Ex.17 The minimum energy necessary to overcome the attractive forces between the electron and the surface of silver metal is $7.52 \times 10^{-19} \text{ J}$. What will be the maximum kinetic energy of the electrons ejected from silver metal which is being irradiated with uv light having a wavelength of 360 \AA .

Sol. K.E. = $h\nu - h\nu_0$

$$\text{K.E.} = \frac{hc}{\lambda} - h\nu_0$$

$$\text{K.E.} = \frac{(6.63 \times 10^{-34} \text{ J sec})(3 \times 10^8 \text{ m/sec})}{3.60 \times 10^{-8} \text{ m}} - 7.52 \times 10^{-19} \text{ J}$$

$$= 4.77 \times 10^{-18} \text{ J}$$

Ex.18 The energy of the electron in the second and third Bohr orbits of the hydrogen atom is $-5.42 \times 10^{-12} \text{ ergs}$ and $-2.41 \times 10^{-12} \text{ ergs}$ respectively. calculate the wavelength of the emitted radiation when the electron drops from third to second orbit.

Sol. Here, $h = 6.62 \times 10^{-27} \text{ ergs}$

$$E_3 = -2.41 \times 10^{-12} \text{ ergs}$$

$$E_2 = -5.42 \times 10^{-12} \text{ ergs}$$

$$\begin{aligned} \therefore \Delta E &= E_3 - E_2 \\ &= -2.41 \times 10^{-12} + 5.42 \times 10^{-12} \\ &= 3.01 \times 10^{-12} \text{ ergs} \end{aligned}$$

Now we know that, $\Delta E = h\nu$

$$\begin{aligned} \therefore \nu &= \frac{\Delta E}{h} = \frac{3.01 \times 10^{-12}}{6.62 \times 10^{-27}} \\ &= \frac{3.01}{6.62} \times 10^{15} \text{ cycles/sec} \end{aligned}$$

But $\nu = \frac{c}{\lambda} \quad \therefore \lambda = \frac{c}{\nu}$

$$\text{or } \lambda = \frac{3 \times 10^{10} \times 6.62}{3.01 \times 10^{15}} = 6.6 \times 10^{-5} \text{ cm}$$

Since $1 \text{ \AA} = 10^{-8} \text{ cm}$

$$\therefore \lambda = \frac{6.6 \times 10^{-5}}{10^{-8}} = 6.6 \times 10^3 \text{ \AA}$$

Ex.19 Calculate the velocity (cm/sec.) of an electron placed in the third orbit of the hydrogen atom. Also calculate the number of revolutions per second that this electron makes around the nucleus.

Sol. Radius of 3rd orbit
 $= 3^2 \times 0.529 \times 10^{-8} = 4.761 \times 10^{-8} \text{ cm}$
 We know that

$$mvr = \frac{nh}{2\pi} \quad \text{or} \quad v = \frac{nh}{2\pi mr}$$

$$\begin{aligned} &= \frac{3 \times 6.624 \times 10^{-27}}{2 \times 3.14 \times (9.108 \times 10^{-28}) \times (4.761 \times 10^{-8})} \\ &= 0.729 \times 10^8 \text{ cm/sec} \end{aligned}$$

$$\text{Time taken for one revolution} = \frac{2\pi r}{v}$$

Number of revolutions per second

$$\begin{aligned} &= \frac{1}{\frac{2\pi r}{v}} = \frac{v}{2\pi r} = \frac{0.729 \times 10^8}{2 \times 3.14 \times 4.716 \times 10^{-8}} \\ &= 2.4 \times 10^{14} \text{ revolutions/sec} \end{aligned}$$

Ex.20 (a) Neglecting reduced-mass defects, what possible transition in the He^+ spectrum would have the same wavelength as the first Lyman transition of hydrogen ($n = 2$ to $n = 1$) ? (b) What is the radius of the first Bohr orbit of He^+ ?

Sol. (a) He^+ has only one electron, hence it can be classified as a hydrogen like species with $Z = 2$, and the Bohr equation may thus be applied.

$$\bar{\nu} = RZ^2 \left(\frac{1}{n_1^2} - \frac{1}{n_2^2} \right)$$

The first Lyman transition for hydrogen ($Z = 1$) would be given by.

$$\bar{\nu} = R \left(\frac{1}{1^2} - \frac{1}{2^2} \right)$$

Since the reduced mass defect is neglected, the R for He^+ is same as for ^1H , the Z^2 term can be compensate by increasing n_1 to $2n_2$ and 4, i.e.

$$\bar{v} = RZ^2 \left(\frac{1}{n_1^2} - \frac{1}{n_2^2} \right) = R(2^2) \left(\frac{1}{2^2} - \frac{1}{4^2} \right)$$

The transition in question is thus the transition from $n = 4$ to $n = 2$.

- (b) The radii of the Bohr's orbit of He^+ may be determined by the following relation

$$r = \frac{n^2}{Z} r_0$$

Thus $r = \frac{1^2 \times 0.529}{2} = 0.264 \text{ \AA}$

($\therefore r_0 = 0.529 \text{ \AA}$)

- Ex.21** A neutral atom has 2K, 8L, 5M electrons. Find out the following from the data : (a) atomic number, (b) total number of s electrons, (c) total number of p electrons, (d) number of protons in the nucleus, and (e) valency of element.

- Sol.** (a) Atomic number = No. of protons = No. of electrons
Total number of electrons = $2 + 8 + 5 = 15$
Hence atomic number = 15
- (b) Total number of s electrons. To find out it, we are to write electronic configuration of At. No. = 15
 $1s^2, 2s^2, 2p^6, 3s^2, 3p^3$
 \therefore Total s electron = 6
- (c) Total number of p electrons = 9
- (d) No. of protons in the nucleus = No. of electrons in extra-nuclear part
 \therefore Number of protons = 15
- (e) Valency. The arrangement of electrons in orbits is 2, 8, 5. As the atom tends to gain three electrons, therefore it is trivalent electronegative (-3).

- Ex.22** Find the number of quanta of radiations of frequency $4.67 \times 10^{13} \text{ s}^{-1}$ that must be absorbed in order to melt 5g of ice. The energy required to melt 1g of ice is 333 J.

- Sol.** Energy required to melt 5g of ice
 $= 5 \times 333 = 1665 \text{ J}$
Energy associated with one quantum
 $= h\nu = (6.62 \times 10^{-34}) \times (4.67 \times 10^{13})$
 $= 30.91 \times 10^{-21} \text{ J}$
Number of quanta required to melt 5 g of ice
 $= \frac{1665}{30.91 \times 10^{-21}} = 53.8 \times 10^{21} = 5.38 \times 10^{22}$

- Ex.23** Applying de Broglie's equation, calculate the wavelength associated with the motion of the earth, a stone and an electron, the masses and velocities of which are given below.

Mass of earth = $6 \times 10^{27} \text{ g} = 6 \times 10^{24} \text{ kg}$

Mass of stone = $100 \text{ g} = 0.1 \text{ kg}$

Mass of electron = $10^{-27} \text{ g} = 10^{-30} \text{ kg}$

Velocity of orbital motion of the earth

$$= 3 \times 10^6 \text{ cm sec}^{-1} = 3 \times 10^4 \text{ m s}^{-1}$$

Velocity of stone = $100 \text{ cm sec}^{-1} = 1.0 \text{ ms}^{-1}$

Velocity of electron = $6 \times 10^7 \text{ cm sec}^{-1}$

$$= 6 \times 10^5 \text{ m s}^{-1}$$

$$h = 6.6 \times 10^{-27} \text{ erg-sec} = 6.6 \times 10^{-34} \text{ Js}$$

In case of which of these three objects, will the wavelength be measurable ?

- Sol.** Substituting the value of h , m and u of the three cases in the de Broglie relationship.

(a) In case of earth, $\lambda = \frac{h}{mv}$

$$\lambda = \frac{6.6 \times 10^{-34}}{(6 \times 10^{24}) \times (3 \times 10^4)} = 3.67 \times 10^{-63} \text{ m}$$

(b) In case of stone, $\lambda = \frac{6.6 \times 10^{-34}}{(0.1)(1.0)}$

$$= 6.6 \times 10^{-33} \text{ m}$$

(c) In case of the electron, λ

$$= \frac{6.6 \times 10^{-34}}{(10^{-30})(6 \times 10^5)}$$

$$= 1.1 \times 10^{-9} \text{ m}$$

The wavelength is measurable in case of electron.

- Ex.24** Show that de Broglie's hypothesis applied to an electron moving in a circular orbit leads to Bohr's postulate of quantized angular momentum.

- Sol.** An electron in a circular orbit must have its path length equal to an integral number of wavelengths for reinforcement to occur.

$$\text{Thus, } 2\pi r = n\lambda$$

$$\lambda = \frac{2\pi r}{n} = \frac{h}{mv} \quad ; \quad mvr = \frac{nh}{2\pi}$$

- Ex.25** If the energy difference between two electronic states is $46.12 \text{ kcal mol}^{-1}$. What will be the frequency of the light emitted when the electrons drop from higher to lower states? ($Nh = 9.52 \times 10^{14} \text{ kcal sec mol}^{-1}$, where N is the Avogadro's number and h is the Planck's constant).

- Sol.** $\Delta E = 46.12 \text{ kcal mol}^{-1}$
According to Bohr's theory, $\Delta E = Nh\nu$

$$\text{or } \nu = \frac{\Delta E}{Nh} = \frac{46.12}{9.52 \times 10^{14}} = 4.48 \times 10^{14} \text{ cycles sec}^{-1}$$

- Ex.26** An electron has a speed of $30,000 \text{ cm sec}^{-1}$ accurate upto 0.001%. What is the uncertainty in locating its position.

Sol. $\Delta v = \frac{0.001}{100} \times 30,000$
 $= 0.3 \text{ cm sec}^{-1}$

According to uncertainty principle,

$$\Delta x \cdot \Delta p \approx \frac{h}{4\pi} \quad ; \quad \Delta x \cdot \Delta p \approx \frac{h}{4\pi m}$$

$$\Delta x \times 9.1 \times 10^{-28} \times 0.3 \approx \frac{6.625 \times 10^{-27} \times 7}{4 \times 22}$$

$$\Delta x \approx 1.93 \text{ cm}$$

Ex.27 In the photoelectric effect, an absorbed quantum of light results in the ejection of an electron from the absorber. The K.E. of the ejected electron is equal to the energy of the absorbed photon minus the energy of the longest wavelength photon that causes the effect. Calculate the kinetic energy of the photoelectron produced in cesium by 400 nm light. The critical wavelength for the photoelectric effect in cesium is 660 nm.

Sol. K.E. of electron = $h\nu - h\nu_0$

$$= \frac{hc}{\lambda} - \frac{hc}{\lambda_0}$$

$$= \frac{1240 \text{ nm.eV}}{400} - \frac{1240 \text{ nm.eV}}{660}$$

$$= 1.22 \text{ eV}$$

Ex.28 Show that the wavelength of a 150 g rubber ball moving with a velocity of 50 m sec^{-1} is short enough to be observed.

Sol. $u = 50 \text{ m sec}^{-1} = 50 \times 10^2 \text{ cm sec}^{-1}$, $m = 150 \text{ g}$
 Putting these values in the relation

$$\lambda = \frac{h}{mu} = \frac{6.625 \times 10^{-27}}{150 \times 50 \times 10^2}$$

$$= 8.83 \times 10^{-33} \text{ cm}$$

Since the above wavelength is much lesser than the wavelength of the visible region, it will not be visible.

Ex.29 On the basis of Heisenberg's uncertainty principle, show that the electron cannot exist within the nucleus.

Sol. Radius of the nucleus is of the order of 10^{-13} cm and thus uncertainty in position of electron i.e. (Δx), if it is within the nucleus will

be 10^{-13} cm . Now $\Delta x \cdot \Delta u \geq \frac{h}{4\pi m}$

$$\therefore \Delta u = \frac{6.626 \times 10^{-27}}{4 \times 3.14 \times 9.108 \times 10^{-28} \times 10^{-13}}$$

$$= 5.79 \times 10^{12} \text{ cm/sec}$$

i.e., order of velocity of electron will be 100 times greater than the velocity of light which is impossible. Thus possibility of electron to exist in nucleus is zero.

EXERCISE (Level-1)

Question based on Sub-Atomic particles and Dalton's atomic theory

- Q.1** Proton is -
(A) Nucleus of deuterium
(B) Ionised hydrogen molecule
(C) Ionised hydrogen atom
(D) An α -particle
- Q.2** Which is not deflected by magnetic field -
(A) Neutron (B) Positron
(C) Proton (D) Electron
- Q.3** According to Dalton's atomic theory, an atom can -
(A) Be created
(B) Be destroyed
(C) take part in a chemical reaction
(D) None of these
- Q.4** Arrange α -particle(α), electron (e^-), proton(p) and neutron (n) in increasing order of their e/m value (specific charge, consider magnitude only not sign) -
(A) $\alpha < e^- < p < n$ (B) $n < \alpha < p < e^-$
(C) $n < p < \alpha < e^-$ (D) $e^- < p < n < \alpha$

Question based on Rutherford's Experiment

- Q.5** Rutherford's alpha particle scattering experiment eventually led to the conclusion that -
(A) mass and energy are related
(B) electrons occupy space around the nucleus
(C) neutrons are buried deep in the nucleus
(D) the point of impact with matter can be precisely determined
- Q.6** Which of the following conclusion could not be derived from Rutherford's α -particle scattering experiment ?
(A) Most of the space in the atom is empty
(B) The radius of the atom is about 10^{-10} m while that of nucleus is 10^{-15} m.
(C) Electrons move in a circular path of fixed energy called orbits
(D) Electrons and the nucleus are held together by electrostatic forces of attraction

Question based on Electromagnetic waves, hydrogen spectra & concept of quantization

- Q.7** The line spectra of two elements are not identical because -
(A) the elements do not have the same number of neutrons
(B) they have different mass number
(C) their outermost electrons are at different energy levels
(D) they have different valencies

- Q.8** A certain radio station broadcasts on a frequency of 980 kHz (kilohertz). What is the wavelength of electromagnetic radiation broadcast by the radio station ?
(A) 306 m (B) 3.06 m
(C) 30.6 m (D) 3060 m
- Q.9** Calculate the wavelength of the spectral line when the electron in the hydrogen atom undergoes a transition from fourth energy level to second energy level ?
(A) 4.86 nm (B) 486 nm
(C) 48.6 nm (D) 4860 nm
- Q.10** The wave number of the first line of Balmer series of hydrogen is 15200 cm^{-1} . The wave number of the corresponding line of Li^{2+} ion is -
(A) 15200 cm^{-1} (B) 60800 cm^{-1}
(C) 76000 cm^{-1} (D) 136800 cm^{-1}
- Q.11** The frequency of one of the lines in Paschen series of a hydrogen atom is $2.34 \times 10^{14} \text{ Hz}$. The higher orbit, n_2 , which produces this transitions is -
(A) three (B) four
(C) six (D) five
- Q.12** In hydrogen spectrum, the series of lines appearing in ultra violet region of electromagnetic spectrum are called -
(A) Lyman lines (B) Balmer lines
(C) Pfund lines (D) Brackett lines
- Q.13** Which of the following series of lines in the atomic spectrum of hydrogen appear in the visible region ?
(A) Lyman (B) Paschen
(C) Brackett (D) Balmer
- Q.14** Which of the following is not correct according to Planck's quantum theory ?
(A) Energy is emitted or absorbed discontinuously
(B) Energy of a quantum is directly proportional to its frequency
(C) A photon is also a quantum of light
(D) Energy less than a quantum can also be emitted or absorbed
- Q.15** To which electronic transition between Bohr orbits in hydrogen, the second line in the Balmer series belongs ?
(A) $3 \rightarrow 2$ (B) $4 \rightarrow 2$
(C) $5 \rightarrow 2$ (D) $6 \rightarrow 2$

Question based on

Bohr's atomic model

- Q.16** The ratio of the radii of first three Bohr orbits is
(A) 1 : 05 : 3 (B) 1 : 2 : 3
(C) 1 : 4 : 9 (D) 1 : 8 : 27
- Q.17** The ionization energy of per mole of hydrogen atom in terms of Rydberg constant (R_H) is given by the expression -
(A) $R_H hc$ (B) $R_H c$
(C) $2 R_H hc$ (D) $R_H N_A hc$
- Q.18** The frequency of first line of Balmer series in hydrogen atom is ν_0 . The frequency of corresponding line emitted by singly ionised helium atom is -
(A) $2\nu_0$ (B) $4\nu_0$
(C) $\nu_0/2$ (D) $\nu_0/4$
- Q.19** Energy of third orbit of Bohr's atom is -
(A) - 13.6 eV
(B) - 3.4 eV
(C) - 1.51 eV
(D) None of the three
- Q.20** If the radius of first Bohr orbit be a_0 , then the radius of the third orbit would be -
(A) $3 \times a_0$ (B) $6 \times a_0$
(C) $9 \times a_0$ (D) $1/9 \times a_0$
- Q.21** In H-atom electron jumps from 3rd to 2nd energy level, the energy released is -
(A) $3.03 \times 10^{-19} \text{ J/atom}$
(B) $1.03 \times 10^{-19} \text{ J/atom}$
(C) $3.03 \times 10^{-12} \text{ J/atom}$
(D) $6.06 \times 10^{-19} \text{ J/atom}$
- Q.22** The ratio of ionization energy of H and Be^{+3} is-
(A) 1 : 1 (B) 1 : 3
(C) 1 : 9 (D) 1 : 16
- Q.23** The ionization energy of hydrogen atom (in the ground state) is x kJ. The energy required for an electron to jump from 2nd orbit to the 3rd orbit will be -
(A) $x/6$ (B) $5x$
(C) $7.2x$ (D) $5x/36$
- Q.24** In two H atoms X and Y the electrons move around the nucleus in circular orbits of radius r and $4r$ respectively. The ratio of the times taken by them to complete one revolution is -
(A) 1 : 4 (B) 1 : 2
(C) 1 : 8 (D) 2 : 1

Question based on

Photoelectric effect, Dual Nature of electron & Heisenberg's uncertainty principle

- Q.25** If threshold wavelength (λ_0) for ejection of electron from metal is 330 nm, then work function for the photoelectric emission is -
(A) $1.2 \times 10^{-18} \text{ J}$ (B) $1.2 \times 10^{-20} \text{ J}$
(C) $6 \times 10^{-19} \text{ J}$ (D) $6 \times 10^{-12} \text{ J}$
- Q.26** The kinetic energy of the electron emitted when light of frequency $3.5 \times 10^{15} \text{ Hz}$ falls on a metal surface having threshold frequency $1.5 \times 10^{15} \text{ Hz}$ is ($h = 6.6 \times 10^{-34} \text{ Js}$)
(A) $1.32 \times 10^{-18} \text{ J}$ (B) $3.3 \times 10^{-18} \text{ J}$
(C) $6.6 \times 10^{-19} \text{ J}$ (D) $1.98 \times 10^{-19} \text{ J}$
- Q.27** Light of wavelength λ shines on a metal surface with intensity x and the metal emits y electrons per second of average energy, z . What will happen to y and z if x is doubled?
(A) y will be doubled and z will become half
(B) y will remain same and z will be doubled
(C) both y and z will be doubled
(D) y will be doubled but z will remain same
- Q.28** A 200g cricket ball is thrown with a speed of $3.0 \times 10^3 \text{ cm sec}^{-1}$. What will be its de Broglie's wavelength? [$h = 6.6 \times 10^{-27} \text{ g cm}^2 \text{ sec}^{-1}$]
(A) $1.1 \times 10^{-32} \text{ cm}$ (B) $2.2 \times 10^{-32} \text{ cm}$
(C) $0.55 \times 10^{-32} \text{ cm}$ (D) $11.0 \times 10^{-32} \text{ cm}$
- Q.29** If uncertainty in the position of an electron is zero, the uncertainty in its momentum would be
(A) zero (B) $< h/(4\pi)$
(C) $> h/(4\pi)$ (D) infinite
- Q.30** Heisenberg uncertainty principle states that -
(A) Moving bodies exhibit both particle and wave character
(B) Neither the position nor the momentum of a particle can be precisely determined
(C) Simultaneous determination of position and momentum of a microscopic particle is not possible.
(D) Moving charged particles resemble electromagnetic waves in their behavior
- Q.31** Calculate the uncertainty in velocity of a cricket ball of mass 150 g if the uncertainty in its position is 1 \AA ($h = 6.6 \times 10^{-34} \text{ kg m}^2 \text{ s}^{-1}$)
(A) $3.5 \times 10^{-24} \text{ ms}^{-1}$
(B) $4.5 \times 10^{-24} \text{ ms}^{-1}$
(C) $3.5 \times 10^{-24} \text{ cms}^{-1}$
(D) $4.5 \times 10^{-24} \text{ cms}^{-1}$

Question based on

Schrodinger wave theory, quantum number & shape of orbitals

- Q.32** Which of the following statements is incorrect?
 (A) Probabilities are found by solving Schrodinger wave equation
 (B) Energy of the electron in an atom at infinite distance is zero and yet it is maximum
 (C) Some spectral lines of an element may have the same wave number
 (D) The position and momentum of a rolling ball can be measured accurately
- Q.33** For s-orbitals, since (ψ orbital wave function) is independent of angles, the probability density (ψ^2) is -
 (A) also independent of angles
 (B) spherically symmetric
 (C) both (A) and (B) are correct
 (D) both (A) and (B) are incorrect
- Q.34** With the increasing principal quantum number, the energy difference between adjacent energy levels in H-atom -
 (A) decreases
 (B) increases
 (C) remains constant
 (D) decreases for low value of Z and increases for higher value of Z
- Q.35** How many electrons can fit into the orbitals that comprise the 3rd quantum shell $n = 3$?
 (A) 2 (B) 8
 (C) 18 (D) 32
- Q.36** Which of the following statements concerning the four quantum numbers is false -
 (A) n gives idea of the size of an orbital
 (B) l gives the shape of an orbital
 (C) m_s gives the energy of the electron in the orbital in absence of magnetic field
 (D) m_s gives the direction of spin angular momentum of the electron in an orbital
- Q.37** Which of the following statements is not correct ?
 (A) The shape of an atomic orbital depends on the azimuthal quantum number
 (B) The orientation of an atomic is given by magnetic quantum number
 (C) The energy of an electron in an atomic orbital of multi electron atom depends on the principal quantum number only
 (D) The number of degenerate atomic orbitals of one type depends on the values of azimuthal and magnetic quantum numbers

Question based on

Aufbau rule and e- configuration

- Q.38** The manganese ($Z = 25$) has the outer configuration
- (A) $4s \leftarrow \boxed{\uparrow\downarrow} \quad \boxed{\uparrow\downarrow} \quad \boxed{\uparrow} \quad \boxed{\uparrow} \quad \boxed{\uparrow} \quad \boxed{\uparrow} \quad \rightarrow 3d$
- (B) $4s \leftarrow \boxed{\uparrow\downarrow} \quad \boxed{\uparrow} \quad \boxed{\uparrow} \quad \boxed{\uparrow} \quad \boxed{\uparrow} \quad \boxed{\uparrow} \quad \rightarrow 3d$
- (C) $4s \leftarrow \boxed{\uparrow\downarrow} \quad \boxed{\uparrow\downarrow} \quad \boxed{\uparrow\downarrow} \quad \boxed{\uparrow} \quad \boxed{} \quad \boxed{} \quad \rightarrow 3d$
- (D) $4s \leftarrow \boxed{} \quad \boxed{\uparrow\downarrow} \quad \boxed{\uparrow\downarrow} \quad \boxed{\uparrow} \quad \boxed{\uparrow} \quad \boxed{\uparrow} \quad \rightarrow 3d$
- Q.39** If the electronic structure of oxygen atom is written as $1s^2, 2s^2$ $\overbrace{\boxed{\uparrow\downarrow} \quad \boxed{\uparrow\downarrow} \quad \boxed{}}^{2p}$ it would violate -
 (A) Hund's rule
 (B) Pauli's exclusion principle
 (C) Both Hund's and Pauli's principles
 (D) None of these
- Q.40** A given orbital is labelled by the magnetic quantum number $m = -1$. This can not be -
 (A) s-orbital (B) d-orbital
 (C) p-orbital (D) f-orbital

EXERCISE (Level-2)

- Q.1** What is the maximum number of electrons in an atom that can have the quantum numbers $n = 4, m_l = +1$?
 (A) 4 (B) 15 (C) 3 (D) 6
- Q.2** Arrange the orbitals of H-atom in the increasing order of their energy -
 $3p_x, 2s, 4d_{xy}, 3s, 4p_z, 3p_y, 4s$
 (A) $2s < 3s = 3p_x = 3p_y < 4s = 4p_z = 4d_{xy}$
 (B) $2s < 3s < 3p_x = 3p_y < 4s = 4p_z = 4d_{xy}$
 (C) $2s < 3s < 3p_x = 3p_y < 4s = 4p_z = 4d_{xy}$
 (D) $2s < 3s < 3p_x = 3p_y < 4s < 4p_z < 4d_{xy}$
- Q.3** If the I.P. of Li^{+2} is 122.4 eV. Find out 6th I.P. of carbon -
 (A) $122.4 \times 4\text{eV}$ (B) $122.4 \times 2\text{eV}$
 (C) $122.4 \times 3\text{eV}$ (D) $122.4 \times 5\text{eV}$
- Q.4** The energy difference between two electronic states is 46.12 kcal/mole. What will be the frequency of the light emitted when an electron drops from the higher to the lower energy state (Planck's constant = 9.52×10^{-14} kcal sec mole⁻¹)
 (A) 4.84×10^{15} cycles sec⁻¹
 (B) 4.84×10^{-5} cycles sec⁻¹
 (C) 4.84×10^{-12} cycles sec⁻¹
 (D) 4.84×10^{14} cycles sec⁻¹
- Q.5** If the kinetic energy of an electron is increased 4 times, the wavelength of the de Broglie wave associated with it would become :
 (A) 4 times (B) 2 times
 (C) 1/2 times (D) 1/4 times
- Q.6** Multiple of fine structure of spectral lines is due to-
 (A) Presence of main energy levels
 (B) Presence of sub-levels
 (C) Presence of electronic configuration
 (D) Is not a characteristics of the atom.
- Q.7** Wave mechanical mode of the atom depends upon-
 (A) de-Broglie concept of dual nature of electron
 (B) Heisenberg uncertainty principle
 (C) Schrodinger uncertainty principle
 (D) All
- Q.8** Calculate total no. of e⁻ having $m = 0$ in Cr atom -
 (A) 12 (B) 13 (C) 5 (D) 24
- Q.9** Which of the following subshell can accommodate as many as 10 electrons -
 (A) 2d (B) 3d (C) $3d_{xy}$ (D) $3d_{z^2}$
- Q.10** How many spherical nodes are present in a 4s orbital in hydrogen atom -
 (A) 0 (B) 1 (C) 2 (D) 3
- Q.11** Assuming the velocity to be same which subatomic particle possesses smallest de-Broglie wavelength -
 (A) An electron
 (B) A proton
 (C) An α -particle
 (D) All have same wavelength
- Q.12** I.P. of hydrogen atom is equal to 13.6 eV. What is the energy required for the process :
 $\text{He}^+ + \text{energy} \longrightarrow \text{He}^{+2} + \text{e}^-$
 (A) 2×13.6 eV (B) 1×13.6 eV
 (C) 4×13.6 eV (D) None of these
- Q.13** If elements with principal quantum number $n > 4$ is not allowed in nature, the number of possible elements would be -
 (A) 60 (B) 32 (C) 64 (D) 50
- Q.14** If the value of $(n + l)$ is not > 3 , then the maximum number of electrons in all the orbitals would be -
 (A) 12 (B) 10 (C) 2 (D) 6
- Q.15** It is not possible to explain the Pauli's exclusion principle with the help of this atom -
 (A) B (B) Be (C) C (D) H
- Q.16** How fast is an electron moving if it has a wavelength equal to the distance it travels in one second -
 (A) $\sqrt{\frac{h}{m}}$ (B) $\sqrt{\frac{m}{h}}$ (C) $\sqrt{\frac{h}{p}}$ (D) $\sqrt{\frac{h}{2(\text{KE})}}$
- Q.17** An atom has a mass of 0.02 kg & uncertainty in its velocity is 9.218×10^{-6} m/s then uncertainty in position is
 ($h = 6.626 \times 10^{-34}$ J - s)
 (A) 2.86×10^{-28} m (B) 2.86×10^{-32} cm
 (C) 1.5×10^{-27} m (D) 3.9×10^{-10} m
- Q.18** Energy of H-atom in the ground state is -13.6 eV, Hence energy in the second excited state is -
 (A) -6.8 eV (B) -3.4 eV
 (C) -1.51 eV (D) -4.3 eV
- Q.19** Uncertainty in position of a particle of 25 g in space is 10^{-5} m. Hence uncertainty in velocity (ms^{-1}) is (Planck's constant $h = 6.6 \times 10^{-34}$ Js)
 (A) 2.1×10^{-28} (B) 2.1×10^{-34}
 (C) 0.5×10^{-34} (D) 5.0×10^{-24}
- Q.20** The orbital angular momentum for an electron revolving in an orbit is given by $\sqrt{\ell(\ell+1)} \cdot \frac{h}{2\pi}$. This momentum for an s-electron will be given by
 (A) $\frac{h}{2\pi}$ (B) $\sqrt{2} \cdot \frac{h}{2\pi}$
 (C) $+\frac{1}{2} \cdot \frac{h}{2\pi}$ (D) zero

- Q.21** Which of the following sets of quantum numbers is correct for an electron in 4f orbital ?
 (A) $n = 4, \ell = 3, m = +4, s = +\frac{1}{2}$
 (B) $n = 4, \ell = 4, m = -4, s = -\frac{1}{2}$
 (C) $n = 4, \ell = 3, m = +1, s = +\frac{1}{2}$
 (D) $n = 3, \ell = 3, m = -2, s = +\frac{1}{2}$
- Q.22** Consider the ground state of Cr atom ($Z = 24$). The number of electrons with the azimuthal quantum numbers, $\ell = 1$ and 2 are, respectively
 (A) 12 and 4 (B) 12 and 5
 (C) 16 and 4 (D) 16 and 5
- Q.23** The triad of nuclei that is isotonic is -
 (A) ${}^{14}_6\text{C}, {}^{15}_7\text{N}, {}^{17}_9\text{F}$ (B) ${}^{12}_6\text{C}, {}^{14}_7\text{N}, {}^{19}_9\text{F}$
 (C) ${}^{14}_6\text{C}, {}^{14}_7\text{N}, {}^{17}_9\text{F}$ (D) ${}^{14}_6\text{C}, {}^{14}_7\text{N}, {}^{19}_9\text{F}$
- Q.24** The orbital angular momentum of an electron in 2s orbital is -
 (A) $+\frac{1}{2} \cdot \frac{h}{2\pi}$ (B) zero
 (C) $\frac{h}{2\pi}$ (D) $\sqrt{2} \cdot \frac{h}{2\pi}$
- Q.25** In potassium atom, electronic energy level is in the following order -
 (A) $4s > 3d$ (B) $4s < 2p$
 (C) $4s < 3d$ (D) $4s > 4p$
- Q.26** Which of the following has maximum number of unpaired electron ?
 (A) Mg^{2+} (B) Ti^{3+}
 (C) V^{3+} (D) Fe^{2+}
- Q.27** The first use of quantum theory to explain the structure of atom was made by -
 (A) Heisenberg (B) Bohr
 (C) Planck (D) Einstein
- Q.28** For a d-electron, the orbital angular momentum is -
 (A) $\sqrt{6} \hbar$ (B) $\sqrt{2} \hbar$ (C) \hbar (D) $2 \hbar$
- Q.29** Which of the following statement is not correct ?
 (A) The electronic configuration of Cr is $[\text{Ar}] 3d^5 4s^1$. (Atomic No. of Cr = 24)
 (B) The magnetic quantum number may have a negative value
 (C) In silver atom, 23 electrons have a spin of one type of 24 of the opposite type (Atomic No. of Ag = 47)
 (D) The electronic configuration of Cr is $[\text{Ar}] 3d^4 4s^2$
- Q.30** The energy of an electron in the first Bohr orbit of H atom is -13.6 eV . The possible energy value (s) of the excited state(s) for electrons in Bohr orbits of hydrogen is (are) -
 (A) -3.4 eV (B) -4.2 eV
 (C) -6.8 eV (D) $+6.8 \text{ eV}$
- Q.31** The energy of the electron in the first orbit of He^+ is $-871.6 \times 10^{-20} \text{ J}$. The energy of the electron in the first orbit of hydrogen would be
 (A) $-871.6 \times 10^{-20} \text{ J}$ (B) $-435.8 \times 10^{-20} \text{ J}$
 (C) $-217.9 \times 10^{-20} \text{ J}$ (D) $-108.9 \times 10^{-20} \text{ J}$
- Q.32** The number of nodal planes in a p_x orbitals is -
 (A) two (B) one (C) three (D) zero
- Q.33** The wavelength associated with a golf ball weighing 200g and moving at a speed of 5 m/h is of the order -
 (A) 10^{-10} m (B) 10^{-20} m (C) 10^{-30} m (D) 10^{-40} m
- Q.34** The quantum numbers $+1/2$ and $-1/2$ for the electron spin represent -
 (A) rotation of the electron in clockwise and anticlockwise direction respectively
 (B) rotation of the electron in anticlockwise and clockwise direction respectively
 (C) magnetic moment of the electron pointing up and down respectively
 (D) two quantum mechanical spin states which have no classical analogue
- Q.35** Rutherford's experiment, which established the nuclear model of the atom, used a beam of -
 (A) β -particles, which impinged on a metal foil and got absorbed
 (B) γ -rays, which impinged on a metal foil and ejected electrons
 (C) helium atoms, which impinged on a metal foil and got scattered
 (D) helium nuclei, which impinged on a metal foil and got scattered
- Q.36** If the nitrogen atom had electronic configuration 1s, it would have energy lower than that of the normal ground state configuration $1s^2 2s^2 2p^3$ because the electrons would be closer to the nucleus yet, $1s^7$ is not observed because it violates -
 (A) Heisenberg Uncertainty principle
 (B) Hund's rule
 (C) Pauli's exclusion principle
 (D) Bohr postulates of stationary orbits
- Q.37** For which of the following the radius will be same as for hydrogen atom $n = 1$
 (A) $\text{He}^+, n = 2$ (B) $\text{Li}^{2+}, n = 2$
 (C) $\text{Be}^{3+}, n = 2$ (D) $\text{Li}^{2+}, n = 3$
- Q.38** Maximum numbers of electrons in a subshell is given by -
 (A) $(2\ell+1)$ (B) $2(2\ell+1)$
 (C) $(2\ell+1)^2$ (D) $2(2\ell+1)^2$

- Q.39** Which of the following statements about nodal planes is/are not true -
 (A) A plane on which there is zero probability of finding an electron
 (B) A plane on which there is maximum probability that the electron will be found
 (C) Ψ^2 is non zero at nodal plane
 (D) None of these

- Q.40** For the energy levels in an atom which one of the following statement is correct ?
 (A) The 4s sub-energy level is at a higher energy than the 3d sub-energy level
 (B) The M-energy level can have maximum of 32 electrons
 (C) The second principal energy level can have four orbitals and contain a maximum of 8 electrons
 (D) The 5th main energy level can have maximum of 49 electrons

- Q.41** The electronic configurations of Cr^{24} and Cu^{29} are abnormal -
 (A) Due to extra stability of exactly half filled and exactly fully filled sub shells
 (B) Because they belong to d-block
 (C) Both the above
 (D) None of the above

- Q.42** The below configuration is not correct as it violates

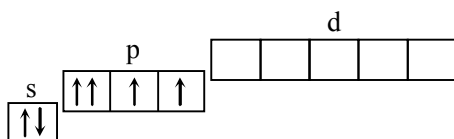

- (A) Only Hund's rule
 (B) Only Pauli's exclusion principle
 (C) $(n + 1)$ rule
 (D) (Hund + Pauli) rule
- Q.43** Wavelength of the first line of Paschen Series is - ($R = 109700 \text{ cm}^{-1}$)
 (A) $[18750 \text{ \AA}]$ (B) $[2854 \text{ \AA}]$
 (C) $[3452 \text{ \AA}]$ (D) $[6243 \text{ \AA}]$
- Q.44** The maximum probability of finding electron in the d_{xy} orbital is -
 (A) Along the x-axis
 (B) Along the y-axis
 (C) At an angle of 45° from the x and y-axis
 (D) At an angle of 90° from the x and y-axis
- Q.45** The nucleus of an atom is located at $x = y = z = 0$. If the probability of finding an s-orbital electron in a tiny volume around $x = a$, $y = z = 0$ is 1×10^{-5} , what is the probability of finding the electron in the same sized volume around $x = z = 0$, $y = a$?
 (A) 1×10^{-5} (B) $1 \times 10^{-5} \times a$
 (C) $1 \times 10^{-5} \times a^2$ (D) $1 \times 10^{-5} \times a^{-1}$

- Q.46** If n and ℓ are respectively the principal and azimuthal quantum numbers, then the expression for calculating the total number of electrons in any energy level is -

$$(A) \sum_{\ell=0}^{\ell=n} 2(2\ell + 1) \quad (B) \sum_{\ell=1}^{\ell=n-1} 2(2\ell + 1)$$

$$(C) \sum_{\ell=0}^{\ell=n+1} 2(2\ell + 1) \quad (D) \sum_{\ell=0}^{\ell=n-1} 2(2\ell + 1)$$

- Q.47** A photon was absorbed by a hydrogen atom in its ground state and the electron was promoted to the fifth orbit. When the excited atom returned to its ground state, visible quanta were emitted when electron made transition -
 (A) $5 \rightarrow 2$ (B) $2 \rightarrow 1$ (C) $3 \rightarrow 1$ (D) $4 \rightarrow 1$

- Q.48** What is the change in the orbit radius when the electron in the hydrogen atom (Bohr model) undergoes the first Paschen transition ?
 (A) $4.23 \times 10^{-10} \text{ m}$ (B) $0.35 \times 10^{-10} \text{ m}$
 (C) $3.7 \times 10^{-10} \text{ m}$ (D) $1.587 \times 10^{-10} \text{ m}$

- Q.49** In centre-symmetrical system, the orbital angular momentum, a measure of the momentum of a particle travelling around the nucleus, is quantised. Its magnitude is -

$$(A) \sqrt{\ell(\ell + 1)} \frac{h}{2\pi} \quad (B) \sqrt{\ell(\ell - 1)} \frac{h}{2\pi}$$

$$(C) \sqrt{s(s + 1)} \frac{h}{2\pi} \quad (D) \sqrt{s(s - 1)} \frac{h}{2\pi}$$

- Q.50** Ultraviolet light of 6.2 eV falls on a aluminium surface (work function = 4.2 eV). The kinetic energy (in joule) of the fastest electron emitted is approximately -

$$(A) 3 \times 10^{-21} \quad (B) 3 \times 10^{-19}$$

$$(C) 3 \times 10^{-17} \quad (D) 3 \times 10^{-15}$$

- Q.51** An electron, a proton and an alpha particle have kinetic energies of 16E, 4E and E respectively. What is the qualitative order of their de-Broglie wavelengths ?

$$(A) \lambda_e > \lambda_p = \lambda_\alpha \quad (B) \lambda_p = \lambda_\alpha > \lambda_e$$

$$(C) \lambda_p > \lambda_e > \lambda_\alpha \quad (D) \lambda_\alpha < \lambda_e \gg \lambda_p$$

- Q.52** One energy difference between the states $n = 2$ and $n = 3$ is E eV, in hydrogen atom. The ionisation potential of H atom is -
 (A) 3.2 E (B) 5.6 E
 (C) 7.2 E (D) 13.2 E

- Q.53** Magnetic moments of $\text{V}(Z = 23)$, $\text{Cr}(Z = 24)$, $\text{Mn}(Z = 25)$ are x, y, z. Hence -
 (A) $x = y = z$ (B) $x < y < z$
 (C) $x < z < y$ (D) $z < y < x$

- Q.54** If the shortest wavelength of H atom in Lyman series is x, then longest wavelength in Balmer series of He^+ is -

$$(A) \frac{9x}{5} \quad (B) \frac{36x}{5} \quad (C) \frac{x}{4} \quad (D) \frac{5x}{9}$$

- Q.55** The specific charge of a proton is $9.6 \times 10^7 \text{ C kg}^{-1}$, then for an α -particles it will be
 (A) $2.4 \times 10^7 \text{ C kg}^{-1}$ (B) $4.8 \times 10^7 \text{ C kg}^{-1}$
 (C) $19.2 \times 10^7 \text{ C kg}^{-1}$ (D) $38.4 \times 10^7 \text{ C kg}^{-1}$
- Q.56** The dissociation energy of H_2 is $430.53 \text{ KJ mol}^{-1}$. If H_2 is dissociated by illuminating with the radiation of wavelength 253.7 nm , the fraction of the radiant energy which will be converted into kinetic energy is given by -
 (A) 8.76 % (B) 12.33 %
 (C) 11.3 % (D) 100%
- Q.57** In an electron microscope, electrons are accelerated to great velocities. Calculate the wavelength of an electron travelling with a velocity of 7.0 megameters per second. The mass of an electron is $9.1 \times 10^{-28} \text{ g}$
 (A) $1.0 \times 10^{-13} \text{ m}$ (B) $1.0 \times 10^{-7} \text{ m}$
 (C) 1.0 m (D) $1.0 \times 10^{-10} \text{ m}$
- Q.58** What are the values of the orbital angular momentum of an electron in the orbitals 1s, 3s, 3d and 2p ?
 (A) $0, 0, \frac{h}{2\pi}\sqrt{6}, \frac{h}{2\pi}\sqrt{2}$
 (B) $1, 1, \frac{h}{2\pi}\sqrt{4}, \frac{h}{2\pi}\sqrt{2}$
 (C) $0, 1, \frac{h}{2\pi}\sqrt{6}, \frac{h}{2\pi}\sqrt{3}$
 (D) $0, 0, \frac{h}{2\pi}\sqrt{20}, \frac{h}{2\pi}\sqrt{6}$
- Q.59** The energy difference between two electronic states is 46.12 kcal/mole . What will be the frequency of the light emitted when an electron drops from the higher to the lower energy state? (Planck's constant = $9.52 \times 10^{-14} \text{ kcal sec mole}^{-1}$)
 (A) $4.84 \times 10^{15} \text{ cycles sec}^{-1}$
 (B) $4.84 \times 10^{-5} \text{ cycles sec}^{-1}$
 (C) $4.84 \times 10^{-12} \text{ cycles sec}^{-1}$
 (D) $4.84 \times 10^{14} \text{ cycles sec}^{-1}$
- Q.60** The radii of two of the first four Bohr orbits of the hydrogen atom are in the ratio 1 : 4. The energy difference between them may be -
 (A) Either 12.09 eV or 3.4 eV
 (B) Either 2.55 eV or 10.2 eV
 (C) Either 13.6 eV or 3.4 eV
 (D) Either 3.4 eV or 0.85 eV
- Q.61** It is known that atoms contain protons, neutrons and electrons. If the mass of neutron is assumed to be half of its original value whereas that of electron is assumed to be twice of this original value. The atomic mass of ${}_{6}\text{C}^{12}$ will be -
 (A) Twice (B) 75% less
 (C) 25% less (D) one-half of its
- Q.62** Calculate total no. of e^- having $m = 0$ in Cr atom -
 (A) 12 (B) 13 (C) 5 (D) 24

- Q.63** The following graph between Ψ^2 probability density and distance from the nucleus represents -

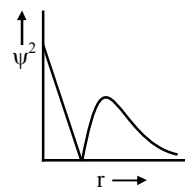

- (A) 2s (B) 3s (C) 1s (D) 2p
- Q.64** In an atomic orbital the sign of the lobes indicates the -
 (A) Sign of the probability distribution
 (B) Sign of charge
 (C) Sign of wave function
 (D) presence or absence of electron
- Q.65** Which of the following symbols represent an atomic orbital ?
 (A) $\Psi_{n, \ell, m} = R_n \Theta_{\ell} \Phi_m$
 (B) $\Psi_{n, \ell, m} = R_{n, \ell} \Theta_{\ell} \Phi_m$
 (C) $\Psi_{n, \ell, m} = R_n \Theta_{\ell, m} \Phi_m$
 (D) $\Psi_{n, \ell, m} = R_{n, \ell} \Theta_{\ell, m} \Phi_m$

- Q.66** The energy of an electron moving in n^{th} Bohr's orbit of an element is given by $E_n = \frac{-13.6}{n^2} Z^2 \text{ eV/atom}$ ($Z = \text{atomic number}$). The graph of E Vs Z^2 (keeping 'n' constant) will be -

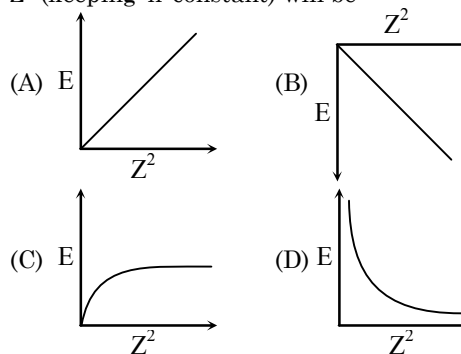

- Q.67** If in Bohr's model, for unielectronic atom, time period of revolution is represented as $T_{n,z}$ where n represents shell no. and Z represents atomic number then the value of $T_{1,2} : T_{2,1}$ will be -
 (A) 8 : 1 (B) 1 : 8 (C) 1 : 1 (D) 1 : 32
- Q.68** An excited state of H atom emits a photon of wavelength λ and returns in the ground state, the principal quantum number of excited state is given by -

(A) $\sqrt{\lambda R(\lambda R - 1)}$ (B) $\sqrt{\frac{\lambda R}{(\lambda R - 1)}}$
 (C) $\sqrt{\lambda R(\lambda R - 1)}$ (D) $\sqrt{\frac{(\lambda R - 1)}{\lambda R}}$

Q.69 The Schrodinger wave equation for hydrogen atom is

$$\Psi_{24} = \frac{1}{4\sqrt{2\pi}} \left(\frac{1}{a_0} \right)^{3/2} \left(2 - \frac{r}{a_0} \right) e^{-r/a_0}$$

where a_0 is Bohr's radius. If the radial node in 2s be at r_0 , then r_0 would be equal to-

- (A) $\frac{a_0}{2}$ (B) $2a_0$ (C) $\sqrt{2}a_0$ (D) $\frac{a_0}{\sqrt{2}}$

Q.70 The Schrodinger wave equation for hydrogen

$$\text{atom is } - \Psi (\text{radial}) = \frac{1}{16\sqrt{4}} \left(\frac{Z}{a_0} \right)^{3/2}$$

$$[(\sigma-1)(\sigma^2-8\sigma+12)] e^{-\sigma/2}$$

Where a_0 and Z are the constant in which answer can be expressed and $\sigma = \frac{2Zr}{a_0}$

minimum and maximum position of radial nodes from nucleus are respectively -

- (A) $\frac{a_0}{Z}, \frac{3a_0}{Z}$ (B) $\frac{a_0}{2Z}, \frac{a_0}{Z}$
 (C) $\frac{a_0}{2Z}, \frac{3a_0}{Z}$ (D) $\frac{a_0}{2Z}, \frac{4a_0}{Z}$

Q.71 A light source of wavelength λ illuminates a metal and ejects photo-electrons with

Another light source of wavelength $\frac{\lambda}{3}$, ejects

photo-electrons from same metal with $(K.E.)_{\max} = 4\text{eV}$. Find the value of work function?

- (A) 1 eV (B) 2 eV
 (C) 0.5 eV (D) None of these

Q.72 A small particle of mass m moves in such a way

that P.E. = $-\frac{1}{2}mkr^2$, where k is a constant and

r is the distance of the particle from origin. Assuming Bohr's model of quantization of angular momentum and circular orbit, r is directly proportional to -

- (A) n^2 (B) n
 (C) \sqrt{n} (D) None of these

Q.73 What is the angular velocity (ω) of an electron occupying second orbit of Li^{2+} ion?

- (A) $\frac{8\pi^3me^4}{h^3}$ (B) $\frac{8\pi^3me^4}{9h^3}$
 (C) $\frac{64}{9} \times \frac{\pi^3me^4}{h^3}$ (D) $\frac{9\pi^3me^4}{h^3}$

Q.74 If radiation corresponding to second line of "Balmer series of Li^{2+} ion, knocked out electron from first excited state of H-atom, then kinetic energy of ejected electron would be -

- (A) 2.55 eV (B) 4.25 eV
 (C) 11.25 eV (D) 19.55 eV

Q.75 An element undergoes a reaction as shown - $X + 2e^- \rightarrow X^{2-}$, energy released = 30.87 eV/atom. If the energy released, is used to dissociate 4 gms of H_2 molecules, equally in to H^+ and H^* ,

where H^* is excited state of H atoms where the electron travels in orbit whose circumference equal to four times its de Broglie's wavelength. Determine the least moles of X that would be required. Given : 1.E. of H = 13.6 eV/atom, bond energy of $\text{H}_2 = 4.526$ eV/molecule

- (A) 1 (B) 2
 (C) 3 (D) 4

Q.76 If the energy of H-atom in the ground state is - E, the velocity of photo-electron emitted when a photon having energy E_p strikes a stationary Li^{2+} ion in ground state, is given by -

- (A) $v = \sqrt{\frac{2(E_p - E)}{m}}$ (B) $v = \sqrt{\frac{2(E_p + 9E)}{m}}$
 (C) $v = \sqrt{\frac{2(E_p - 9E)}{m}}$ (D) $v = \sqrt{\frac{2(E_p - 3E)}{m}}$

Q.77 For a 3x-orbital

$$\Psi(3s) = \frac{1}{9\sqrt{3}} \left(\frac{1}{a_0} \right)^{3/2} (6 - 6\sigma + 6\sigma^2)^{-\sigma/2}; \text{ where}$$

$$\sigma = \frac{2r \cdot Z}{3a_0}$$

What is the maximum radial distance of node from nucleus?

- (A) $\frac{(3 + \sqrt{3})a_0}{Z}$ (B) $\frac{a_0}{Z}$
 (C) $\frac{3(3 + \sqrt{3})a_0}{2Z}$ (D) $\frac{2a_0}{Z}$

Q.78 The energy of a I, II and III energy levels of a certain atom are $E, \frac{4E}{3}$ and $2E$ respectively. A

photon of wavelength λ is emitted during a transition from III to I. What will be the wavelength of emission for transition II to I?

- (A) $\frac{\lambda}{2}$ (B) λ (C) 2λ (D) 3λ

Q.79 In the measurement of quantum efficiency of photosynthesis in green plants, it was found that 10 quanta of red light of wavelength 6850 Å were needed to release one molecule of O_2 . The average energy storage in this process is 112 kcal/mol O_2 evolved. What is the energy conversion efficiency in this experiment?

(Given : 1 cal = 4.18 J; $N_A = 6 \times 10^{23}$; $h = 6.63 \times 10^{-34}$ J.s)

- (A) 23.5 (B) 26.9
 (C) 66.34 (D) 73.1

EXERCISE (Level-3)

Old Examination Questions [JEE Main]

- Q.1** In a multi-electron atom, which of the following orbitals described by the three quantum numbers will have the same energy in the absence of magnetic and electric fields? [AIEEE- 2005]
(a) $n = 1, \ell = 0, m = 0$ (b) $n = 2, \ell = 0, m = 0$
(c) $n = 2, \ell = 1, m = 1$ (d) $n = 3, \ell = 2, m = 1$
(e) $n = 3, \ell = 2, m = 0$
(A) (b) and (c) (B) (a) and (b)
(C) (d) and (e) (D) (c) and (d)
- Q.2** Of the following sets which one does NOT contain isoelectronic species? [AIEEE- 2005]
(A) CN^- , N_2 , C_2^{2-}
(B) PO_4^{3-} , SO_4^{2-} , ClO_4^-
(C) BO_3^{3-} , CO_3^{2-} , NO_3^-
(D) SO_3^{2-} , CO_3^{2-} , NO_3^-
- Q.3** According to Bohr's theory, the angular momentum of an electron in 5th orbit is - [AIEEE 2006]
(A) $1.0 h/\pi$ (B) $10 h/\pi$
(C) $2.5 h/\pi$ (D) $25 h/\pi$
- Q.4** Uncertainty in the position of an electron (mass = 9.1×10^{-31} kg) moving with a velocity 300 m/s, accurate upto 0.001 %, will be ($h = 6.63 \times 10^{-34}$ Js) [AIEEE 2006]
(A) 5.76×10^{-2} m (B) 1.92×10^{-2} m
(C) 3.84×10^{-2} m (D) 19.2×10^{-2} m
- Q.5** Which of the following sets of quantum numbers represents the highest energy of an atom? [AIEEE 2007]
(A) $n = 3, \ell = 1, m = 1, s = +\frac{1}{2}$
(B) $n = 3, \ell = 2, m = 1, s = +\frac{1}{2}$
(C) $n = 4, \ell = 0, m = 0, s = +\frac{1}{2}$
(D) $n = 3, \ell = 0, m = 0, s = +\frac{1}{2}$
- Q.6** The ionization enthalpy of hydrogen atom is 1.312×10^6 J mol⁻¹. The energy required to excite the electron in the atom from $n = 1$ to $n = 2$ is [AIEEE 2008]
(A) 6.56×10^5 J mol⁻¹
(B) 7.56×10^5 J mol⁻¹
(C) 9.84×10^5 J mol⁻¹
(D) 8.51×10^5 J mol⁻¹
- Q.7** In an atom, an electron is moving with a speed of 600 m/s with an accuracy of 0.005%. Certainty with which the position of the electron can be located is ($h = 6.6 \times 10^{-34}$ kg m²s⁻¹, mass of electron, $m_e = 9.1 \times 10^{-31}$ kg) [AIEEE 2009]
(A) 1.52×10^{-4} m (B) 5.10×10^{-3} m
(C) 1.92×10^{-3} m (D) 3.84×10^{-3} m
- Q.8** Calculate the wavelength (in nanometer) associated with a proton moving at 1.0×10^3 m s⁻¹ (Mass of proton = 1.67×10^{-27} kg and $h = 6.63 \times 10^{-34}$ Js) - [AIEEE 2009]
(A) 0.032 nm (B) 0.40 nm
(C) 2.5 nm (D) 14.0 nm
- Q.9** A gas absorbs a photon of 355 nm and emits at two wavelengths. If one of the emissions is at 680 nm, the other is at : [AIEEE 2011]
(A) 1035 nm (B) 325 nm
(C) 743 nm (D) 518 nm
- Q.10** The frequency of light emitted for the transition $n = 4$ to $n = 2$ of He^+ is equal to the transition in H atom corresponding to which of the following? [AIEEE 2011]
(A) $n = 2$ to $n = 1$ (B) $n = 3$ to $n = 2$
(C) $n = 4$ to $n = 3$ (D) $n = 3$ to $n = 1$
- Q.11** The electrons identified by quantum numbers n and ℓ [AIEEE-2012]
(a) $n = 4, \ell = 1$ (b) $n = 4, \ell = 0$
(c) $n = 3, \ell = 2$ (d) $n = 3, \ell = 1$
can be placed in order of increasing energy as -
(A) (d) < (b) < (c) < (a) (B) (b) < (d) < (a) < (c)
(C) (a) < (c) < (b) < (d) (D) (c) < (d) < (b) < (a)
- Q.12** The following sets of quantum numbers represents four electrons in an atom :
(i) $n = 4, \ell = 1$ (ii) $n = 4, \ell = 0$
(iii) $n = 3, \ell = 2$ (vi) $n = 3, \ell = 1$
The sequence representing increasing order of energy, is : [AIEEE Online-2012]
(A) (i) < (iii) < (ii) < (iv) (B) (ii) < (iv) < (i) < (iii)
(C) (iv) < (ii) < (iii) < (i) (D) (iii) < (i) < (iv) < (ii)
- Q.13** The limiting line in Balmer series will have a frequency of :
(Rydberg constant, $R_\infty = 3.29 \times 10^{15}$ cycles/s) [AIEEE Online-2012]
(A) 3.65×10^{14} s⁻¹ (B) 8.22×10^{14} s⁻¹
(C) 3.29×10^{15} s⁻¹ (D) 5.26×10^{13} s⁻¹
- Q.14** If the kinetic energy of an electron is increased four times, the wavelength of the de-Broglie wave associated with it would become : [AIEEE Online-2012]
(A) Two times (B) Half
(C) One fourth (D) Four times
- Q.15** Which pair of elements with the given atomic numbers is expected to have similar properties? [AIEEE Online-2012]
(A) 11, 12 (B) 40, 72
(C) 20, 36 (D) 10, 28

- Q.16** If the radius of first orbit of H atom is a_0 , the de-Broglie wavelength of an electron in the third orbit is : **[AIEEE Online-2012]**
 (A) $6\pi a_0$ (B) $8\pi a_0$
 (C) $2\pi a_0$ (D) $4\pi a_0$
- Q.17** In an atom how many orbital (s) will have the quantum numbers, $n = 3$, $\ell = 2$ and $m_\ell = +2$? **[JEE Main Online-2013]**
 (A) 5 (B) 3
 (C) 1 (D) 7
- Q.18** The wave number of the first emission line in the Balmer series of H-Spectrum is – (R = Rydberg constant) **[JEE Main Online-2013]**
 (A) $\frac{5}{36}R$ (B) $\frac{9}{400}R$
 (C) $\frac{7}{6}R$ (D) $\frac{3}{4}R$
- Q.19** The numbers of protons, electrons and neutrons in a molecule of heavy water are respectively : **[JEE Main Online-2013]**
 (A) 8, 10, 11 (B) 10, 10, 10
 (C) 10, 11, 10 (D) 11, 10, 10
- Q.20** The de Broglie wavelength of a car of mass 1000kg and velocity 36 km/hr is : (h = 6.63×10^{-34} Js) **[JEE Main Online-2013]**
 (A) 6.626×10^{-34} m (B) 6.626×10^{-38} m
 (C) 6.626×10^{-31} m (D) 6.626×10^{-30} m
- Q.21** Energy of an electron is given by $E = -2.178 \times 10^{-18} \text{ J} \left(\frac{Z^2}{n^2} \right)$. Wavelength of light required to excite an electron in an hydrogen atom from level $n = 1$ to $n = 2$ will be : (h = 6.62×10^{-34} Js and $c = 3.0 \times 10^8 \text{ ms}^{-1}$) **[JEE-Main 2013]**
 (A) 6.500×10^{-7} m (B) 8.500×10^{-7} m
 (C) 1.214×10^{-7} m (D) 2.816×10^{-7} m
- Q.22** The correct set of four quantum numbers for the valence electrons of rubidium atom ($Z = 37$) is -
 (A) 5, 1, 0 + $\frac{1}{2}$ (B) 5, 1, 1 + $\frac{1}{2}$
 (C) 5, 0, 1 + $\frac{1}{2}$ (D) 5, 0, 0 + $\frac{1}{2}$
- Q.23** Given
 (a) $n = 5$, $m_\ell = +1$
 (b) $n = 2$, $\ell = 1$, $M_\ell = -1$, $m_s = -1/2$
 The maximum number of electron (s) in an atom that can have the quantum numbers as given in (a) and (b) are respectively – **[JEE Main Online - 2014]**
 (A) 25 and 1 (B) 8 and 1
 (C) 2 and 4 (D) 4 and 1
- Q.24** Ionization energy of gaseous Na atoms is 495.5 kJmol^{-1} . The lowest possible frequency of light that ionizes a sodium atom is **[JEE Main Online - 2014]**
 (h = 6.626×10^{-34} Js, $N_A = 6.022 \times 10^{23} \text{ mol}^{-1}$)
 (A) $7.50 \times 10^4 \text{ s}^{-1}$ (B) $4.76 \times 10^{14} \text{ s}^{-1}$
 (C) $3.15 \times 10^{15} \text{ s}^{-1}$ (D) $1.24 \times 10^{15} \text{ s}^{-1}$
- Q.25** If m and e are the mass and charge of the revolving electron in the orbit of radius r for hydrogen atom, the total energy of the revolving electron will be: **[JEE Main Online - 2014]**
 (A) $\frac{1}{2} \frac{e^2}{r}$ (B) $-\frac{e^2}{r}$
 (C) $\frac{me^2}{r}$ (D) $-\frac{1}{2} \frac{e^2}{r}$
- Q.26** The de-Broglie wavelength of a particle of mass 6.63 g moving with a velocity of 100 ms^{-1} is : **[JEE Main Online - 2014]**
 (A) 10^{-33} m (B) 10^{-35} m
 (C) 10^{-31} m (D) 10^{-25} m
- Q.27** Excited hydrogen atom emits light in the ultraviolet region at $2.47 \times 10^{15} \text{ Hz}$. With this frequency, the energy of a single photon is : (h = 6.63×10^{-34} Js) **[JEE Main Online - 2014]**
 (A) 8.041×10^{-40} J (B) 2.680×10^{-19} J
 (C) 1.640×10^{-18} J (D) 6.111×10^{-17} J
- Q.28** The energy of an electron in first Bohr orbit of H-atom is -13.6 eV . The energy value of electron in the excited state of Li^{2+} is : **[JEE Main Online - 2014]**
 (A) -27.2 eV (B) 30.6 eV
 (C) -30.6 eV (D) 27.2 eV
- Q.29** If λ_0 and λ be the threshold wavelength and wavelength of incident light, the velocity of photoelectron ejected from the metal surface is: **[JEE Main Online - 2014]**
[JEE Main 2014]
 (A) $\sqrt{\frac{2h}{m}(\lambda_0 - \lambda)}$ (B) $\sqrt{\frac{2hc}{m}(\lambda_0 - \lambda)}$
 (C) $\sqrt{\frac{2hc}{m} \left(\frac{\lambda_0 - \lambda}{\lambda \lambda_0} \right)}$ (D) $\sqrt{\frac{2h}{m} \left(\frac{1}{\lambda_0} - \frac{1}{\lambda} \right)}$

Q.30 A stream of electrons from a heated filament was passed between two charged plates kept at a potential difference V esu. If e and m are charge and mass of an electron, respectively, then the value of h/λ (where λ is wavelength associated with electron wave) is given by :

[JEE Main - 2016]

- (A) meV (B) $2meV$
 (C) \sqrt{meV} (D) $\sqrt{2meV}$

Q.31 The radius of the second Bohr orbit for hydrogen atom is –

(Planck's Const. $h = 6.6262 \times 10^{-34}$ Js; mass of electron = 9.1091×10^{-31} kg; charge of electron $e = 1.60210 \times 10^{-19}$ C; permittivity of vacuum $\epsilon_0 = 8.854185 \times 10^{-12}$ $\text{kg}^{-1}\text{m}^{-3}\text{A}^2$)

[JEE Main Offline - 2017]

- (A) 0.529 \AA (B) 2.12 \AA
 (C) 1.65 \AA (D) 7.76 \AA

Q.32 The group having isoelectronic species is

[JEE Main Offline - 2017]

- (A) O^{2-} , F^- , Na , Mg^{2+} (B) O^- , F^- , Na^+ , Mg^{2+}
 (C) O^{2-} , F^- , Na^+ , Mg^{2+} (D) O^- , F^- , Na , Mg^+

Q.33 If the Shortest wavelength in Lyman series of hydrogen atom is A , then the longest wavelength in Paschen series of He^+ is –

[JEE Main Online - 2017]

- (A) $\frac{5A}{9}$ (B) $\frac{36A}{7}$ (C) $\frac{36A}{5}$ (D) $\frac{9A}{5}$

Q.34 The electron in the hydrogen atom undergoes transition from higher orbitals to orbital of radius 211.6 pm. This transition is associated with :

[JEE Main Online - 2017]

- (A) Lyman series (B) Balmer series
 (C) Brackett series (D) Paschen series

Q.35 In the molecular orbital diagram for the molecular ion, N_2^+ , the number of electrons in the σ_{2p} molecular orbital is :

[JEE-Main Online-2018]

- (A) 0 (B) 2 (C) 3 (D) 1

Q.36 Which of the following arrangements shown the schematic alignment of magnetic moments of antiferromagnetic substance?

[JEE-Main Online -2018]

- (A) $\uparrow \downarrow \downarrow \downarrow \downarrow \uparrow$
 (B) $\uparrow \uparrow \uparrow \uparrow \uparrow \uparrow$
 (C) $\uparrow \uparrow \downarrow \uparrow \uparrow \downarrow$
 (D) $\uparrow \downarrow \uparrow \downarrow \uparrow \downarrow$

Q.37 Which of the following best describes the diagram of molecular orbital ?

[JEE-Main Online -2018]

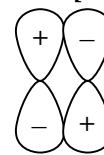

- (A) A bonding π orbital
 (B) A non-bonding orbital
 (C) An antibonding σ orbital
 (D) An antibonding π orbital

Q.38 The de-Broglie's wavelength of electron present in first Bohr orbit of 'H' atom is -

[JEE-Main Online -2018]

- (A) $4 \times 0.529 \text{ \AA}$ (B) $2\pi \times 0.529 \text{ \AA}$
 (C) $\frac{0.529}{2\pi} \text{ \AA}$ (D) 0.529 \AA

Q.39 Which of the following conversions involves change in both shape and hybridization ?

[JEE-Main Online-2018]

- (A) $\text{H}_2\text{O} \rightarrow \text{H}_3\text{O}^+$ (B) $\text{BF}_3 \rightarrow \text{BF}_4^-$
 (C) $\text{CH}_4 \rightarrow \text{C}_2\text{H}_6$ (D) $\text{NH}_3 \rightarrow \text{NH}_4^+$

Q.40 For emission line of atomic hydrogen from $n_1 = 8$ to $n_f = n$, the plot of wave number ($\bar{\nu}$)

against $\left(\frac{1}{n^2}\right)$ will be (The Rydberg constant,

R_H is wave number unit)

[Main -2019]

- (A) Linear with slope $-R_H$
 (B) Linear with slope R_H
 (C) Non linear
 (D) Linear with intercept $-R_H$

Q.41 Which of the following combination of statements is true regarding the interpretation of the atomic orbitals ?

[Main -2019]

- (a) An electron in an orbital of high angular momentum stays away from the nucleus than an electron in the orbital of lower angular momentum.
 (b) For a given value of the principal quantum number, the size of the orbit is inversely proportional to the azimuthal quantum number.
 (c) According to wave mechanics, the ground state angular momentum is equal to $h/2\pi$.
 (d) The plot of ψ Vs r for various azimuthal quantum numbers, shows peak shifting towards higher r value.

- (A) (b), (c) (B) (a), (d)
 (C) (a), (b) (D) (a), (c)

- Q.42** Which primitive unit cell has unequal edge lengths ($a \neq b \neq c$) and all axial angles different from 90° ? [Main -2019]
 (A) Hexagonal (B) Tetragonal
 (C) Triclinic (D) Monoclinic

- Q.43** Which of the graphs shown below does not represent the relationship between incident light and the electron ejected from metal surface? [Main -2019]

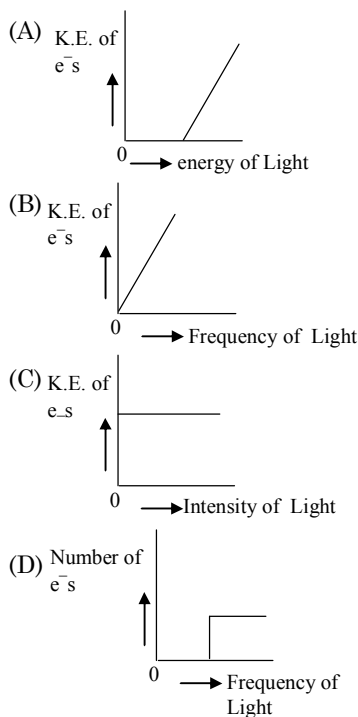

- Q.44** A compound of formula A_2B_3 has the hcp lattice. Which atom forms the hcp lattice and what fraction of tetrahedral voids is occupied by the other atoms? [Main -2019]

- (A) hcp lattice - A, $\frac{1}{3}$ Tetrahedral voids-B
 (B) hcp lattice - B, $\frac{1}{3}$ Tetrahedral voids -A
 (C) hcp lattice - A, $\frac{2}{3}$ Tetrahedral voids -B
 (D) hcp lattice -B, $\frac{2}{3}$ Tetrahedral voids-A

- Q.45** The ground state energy of hydrogen atom is -13.6 eV. The energy of second excited state of He^+ ion in eV is: [Main -2019]
 (A) -6.04 (B) -54.4
 (C) -27.2 (D) -3.4

- Q.46** Heat treatment of muscular pain involves radiation of wavelength of about 900 nm. Which spectral line of H-atom is suitable for this purpose?

- [$R_H = 1 \times 10^5 \text{ cm}^{-1}$, $h = 6.6 \times 10^{-34} \text{ Js}$, $c = 3 \times 10^8 \text{ ms}^{-1}$] [Main-2019]
 (A) Balmer, $\infty \rightarrow 2$ (B) Paschen, $5 \rightarrow 3$
 (C) Paschen, $\infty \rightarrow 3$ (D) Lyman, $\infty \rightarrow 1$

- Q.47** The radius of the largest sphere which fits properly at the centre of the edge of a body centred cubic unit cell is: (Edge length is represented by 'a') [Main -2019]
 (A) $0.134 a$ (B) $0.067 a$
 (C) $0.047 a$ (D) $0.027 a$

- Q.48** The de Broglie wavelength (λ) associated with a photoelectron varies with the frequency (ν) of the incident radiation as, [ν_0 is threshold frequency]: [Main -2019]

- (A) $\lambda \propto \frac{1}{(\nu - \nu_0)^{\frac{3}{2}}}$ (B) $\lambda \propto \frac{1}{(\nu - \nu_0)^{\frac{1}{4}}}$
 (C) $\lambda \propto \frac{1}{(\nu - \nu_0)}$ (D) $\lambda \propto \frac{1}{(\nu - \nu_0)^{\frac{1}{2}}}$

- Q.49** What is the work function of the metal if the light of wavelength 4000 \AA generates photoelectrons of velocity $6 \times 10^5 \text{ ms}^{-1}$ from it? (Mass of electron = $9 \times 10^{-31} \text{ kg}$; Velocity of light = $3 \times 10^8 \text{ ms}^{-1}$; Plank's constant = $6.626 \times 10^{-34} \text{ Js}$; Charge of electron = $1.6 \times 10^{-19} \text{ JeV}^{-1}$) [Main -2019]

- (A) 4.0 eV (B) 0.9 eV
 (C) 2.1 eV (D) 3.1 eV

- Q.50** If the de Broglie wavelength of the electron in n^{th} Bohr orbit in a hydrogenic atom is equal to $1.5 \pi a_0$ (a_0 is Bohr radius), then the value of n/z is - [Main -2019]

- (A) 0.75 (B) 0.40
 (C) 1.50 (D) 1.0

- Q.51** The quantum number of four electrons are given below: [Main -2019]

- I. $n = 4, l = 2, m_l = -2, m_s = -\frac{1}{2}$
 II. $n = 3, l = 2, m_l = 1, m_s = +\frac{1}{2}$
 III. $n = 4, l = 1, m_l = 0, m_s = +\frac{1}{2}$
 IV. $n = 3, l = 1, m_l = 1, m_s = -\frac{1}{2}$

The correct order of their increasing energies will be -

- (A) $I < III < II < IV$ (B) $IV < II < III < I$
 (C) $I < II < III < IV$ (D) $IV < III < II < I$

- Q.52** The size of the iso-electronic species Cl^- , Ar and Ca^{2+} is affected by - **[Main -2019]**
 (A) nuclear charge
 (B) azimuthal quantum number of valence shell
 (C) electron-electron interaction in the outer orbitals
 (D) principal quantum number of valence shell

- Q.53** For silver, $C_p(\text{JK}^{-1} \text{mol}^{-1}) = 23 + 0.01 T$. If the temperature (T) of 3 moles of silver is raised from 300 K to 1000 K at 1 atm pressure, the value of ΔH will be close to- **[Main -2019]**
 (A) 13 kJ (B) 16 kJ
 (C) 62 kJ (D) 21 kJ

- Q.54** The graph between $|\psi|^2$ and r (radial distance) is shown below. This represents : **[Main -2019]**

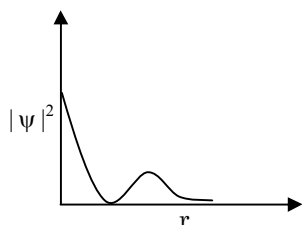

- (A) 3s orbital (B) 2s orbital
 (C) 2p orbital (D) 1s orbital

- Q.55** The ratio of the shortest wavelength of two spectral series of hydrogen spectrum is found to be about 9. The spectral series are: **[Main -2019]**
 (A) Paschen and Pfund
 (B) Balmer and Brackett
 (C) Lyman and Paschen
 (D) Brackett and Pfund

- Q.56** The electrons are more likely to be found : **[Main -2019]**

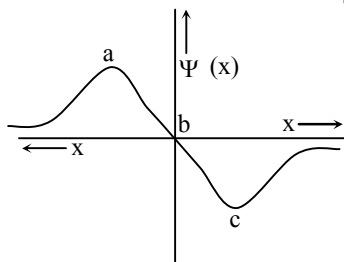

- (A) in the region a and c
 (B) only in the region c
 (C) in the region a and b
 (D) only in the region a

- Q.57** The group number, number of valence electrons, and valency of an element with atomic number 15, respectively, are : **[Main -2019]**
 (A) 16, 6 and 3 (B) 15, 6 and 12
 (C) 16, 5 and 2 (D) 15, 5 and 3

- Q.58** An element has a face-centred cubic (fcc) structure with a cell edge of a. The distance between the centres of two nearest tetrahedral voids in the lattice is : **[Main -2019]**

- (A) a (B) $\frac{3}{2}a$ (C) $\frac{a}{2}$ (D) $\sqrt{2}a$

- Q.59** The ratio of number of atoms present in a simple cubic, body centered cubic and face centered cubic structure are, respectively : **[Main -2019]**

- (A) 8 : 1 : 6 (B) 4 : 2 : 1
 (C) 1 : 2 : 4 (D) 4 : 2 : 3

- Q.60** The number of orbitals associated with quantum numbers $n = 5$, $m_s = +\frac{1}{2}$ is : **[Main -2020]**

- (A) 15 (B) 50 (C) 11 (D) 25

- Q.61** For the Balmer series in the spectrum of H atom, $\bar{\nu} = R_H \left\{ \frac{1}{n_1^2} - \frac{1}{n_2^2} \right\}$, the correct

statements among (I) to (IV) are :

- (I) As wavelength decreases, the lines in the series converge
 (II) The integer n_1 is equal to 2
 (III) The lines of longest wavelength corresponds to $n_2 = 3$
 (IV) The ionization energy of hydrogen can be calculated from wave number of these lines **[Main -2020]**

- (A) (II), (III), (IV) (B) (I), (III), (IV)
 (C) (I), (II), (III) (D) (I), (II), (IV)

- Q.62** Which of the following are isostructural pairs ?

- A. SO_4^{2-} and CrO_4^{2-} B. SiCl_4 and TiCl_4
 C. NH_3 and NO_3^- D. BCl_3 and BrCl_3

[Main -2021]

- (A) C and D only (B) A and B only
 (C) A and C only (D) B and C only

- Q.63** According to Bohr's atomic theory :-

- (A) Kinetic energy of electron is $\propto \frac{Z^2}{n^2}$
 (B) The product of velocity (v) of electron and principal quantum number (n), 'vn' $\propto Z^2$.
 (C) Frequency of revolution of electron in an orbit is $\propto \frac{Z^3}{n^3}$
 (D) Coulombic force of attraction on the electron is $\propto \frac{Z^3}{n^4}$

Choose the most appropriate answer from the options given below : **[Main -2021]**

- (A) (C) Only (B) (A) Only
 (C) (A), (C) and (D) only (D) (A) and (D) only

- Q.64** The plots of radial distribution functions for various orbitals of hydrogen atom against 'r' are given below: **[Main -2021]**

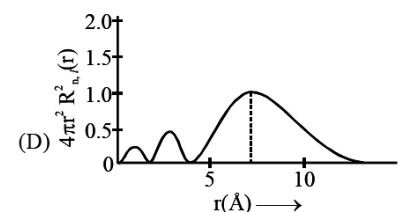
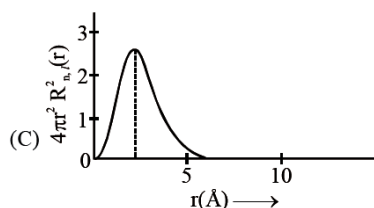
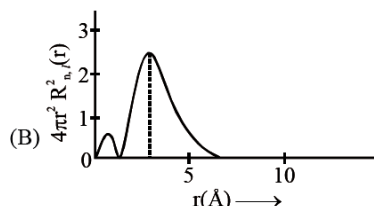
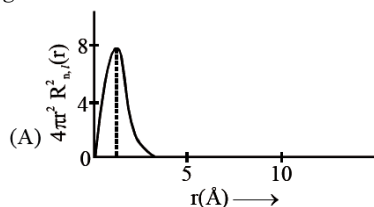

The correct plot for 3s orbital is:

- (A) (B) (B) (A) (C) (D) (D) (C)

- Q.65** The orbital having two radial as well as two angular nodes is - **[Main -2021]**

- (A) 3p (B) 4f (C) 4d (D) 5d

- Q.66** If the radius of the 3rd Bohr's orbit of hydrogen atom is r_3 and the radius of 4th Bohr's orbit is r_4 . Then : **[Main -2022]**

(A) $r_4 = \frac{9}{16}r_3$ (B) $r_4 = \frac{16}{9}r_3$

(C) $r_4 = \frac{3}{4}r_3$ (D) $r_4 = \frac{4}{3}r_3$

- Q.67** Hydrogen has three isotopes: protium (^1H), deuterium (^2H or D) and tritium (^3H or T). They have nearly same chemical properties but different physical properties. They differ in **[Main -2022]**

- (A) Number of protons
(B) Atomic number
(C) Electronic configuration
(D) Atomic mass

- Q.68** Which of the following statements are correct ?
(a) The electronic configuration of Cr is $[\text{Ar}] 3d^5 4s^1$.

(b) The magnetic quantum number may have a negative value.

(c) In the ground state of an atom, the orbitals are filled in order of their increasing energies.

(d) The total number of nodes are given by $n - 2$.

Choose the **most appropriate** answer from the options given below : **[Main -2022]**

(A) (a), (c) and (d) only (B) (a) and (b) only

(C) (a) and (c) only (D) (a), (b) and (c) only

- Q.69** The correct decreasing order of energy for the orbitals having, following set of quantum numbers: **[Main -2022]**

(1) $n = 3, \ell = 0, m = 0$

(2) $n = 4, \ell = 0, m = 0$

(3) $n = 3, \ell = 1, m = 0$

(4) $n = 3, \ell = 2, m = 1$

(A) (4) > (2) > (3) > (1) (B) (2) > (4) > (3) > (1)

(C) (3) > (2) > (4) > (1) (D) (2) > (3) > (4) > (1)

- Q.70** If the uncertainty in velocity and position of a minute particle in space are, $2.4 \times 10^{-26} \text{ (m s}^{-1}\text{)}$ and 10^{-7} (m) respectively. The mass of the particle in g is _____. (Nearest integer) (Given : $h = 6.626 \times 10^{-34} \text{ Js}$) **[Main -2022]**

- Q.71** Consider the following set of quantum numbers.

	n	l	m_l
A.	3	3	-3
B.	3	2	-2
C.	2	1	+1
D.	2	2	+2

The number of correct sets of quantum numbers is _____. **[Main -2022]**

- Q.72** Consider an imaginary ion ${}_{22}^{48}\text{X}^{3-}$. The nucleus contains 'a%' more neutrons than the number of electrons in the ion. The value of 'a' is _____. [nearest integer] **[Main -2022]**

- Q.73** Maximum number of electrons that can be accommodated in shell with $n = 4$ are :

[Main -2023]

(A) 72 (B) 32

(C) 16 (D) 50

Q.74 The wave function (Ψ) of 2s is given by

$$\Psi_{2s} = \frac{1}{2\sqrt{2\pi}} \left(\frac{1}{a_0} \right)^{1/2} \left(2 - \frac{r}{a_0} \right) e^{-r/2a_0}$$

At $r = r_0$, radial node is formed, Thus, r_0 in term of a_0 **[Main -2023]**

- (A) $r_0 = 2a_0$ (B) $r_0 = 4a_0$
 (C) $r_0 = a_0$ (D) $r_0 = \frac{a_0}{2}$

Q.75 The radius of the 2nd orbit of Li^{2+} is x . The expected radius of the 3rd orbit of Be^{3+} is :

[Main -2023]

- (A) $\frac{9}{4}x$ (B) $\frac{16}{27}x$ (C) $\frac{27}{16}x$ (D) $\frac{4}{9}x$

Q.76 If the radius of the first orbit of hydrogen atom is a_0 , then de Broglie's wavelength of electron in 3rd orbit is **[Main -2023]**

- (A) $\frac{\pi a_0}{6}$ (B) $\frac{\pi a_0}{3}$
 (C) $6\pi a_0$ (D) $3\pi a_0$

Q.77 The total number of isoelectronic species from the given set is _____. **[Main -2023]**
 O^{2-} , F^- , Al , Mg^{2+} , Na^+ , O^+ , Mg , Al^{3+} , F

Q.78 The number of electrons present in all the completely filled subshells having $n = 4$ and $s = +\frac{1}{2}$ is _____.

(Where n = principal quantum number and s = spin quantum number) **[Main -2024]**

Q.79 Choose the correct option having all the elements with d^{10} electronic configuration from the following : **[Main -2024]**

- (A) ^{27}Co , ^{28}Ni , ^{26}Fe , ^{24}Cr
 (B) ^{46}Pd , ^{28}Ni , ^{26}Fe , ^{24}Cr
 (C) ^{29}Cu , ^{30}Zn , ^{48}Cd , ^{47}Ag
 (D) ^{28}Ni , ^{24}Cr , ^{26}Fe , ^{29}Cu

Q.80 The correct set of four quantum numbers for the valence electron of rubidium atom ($Z = 37$) is:

[Main -2024]

- (A) 5, 0, 0, $+\frac{1}{2}$ (B) 5, 0, 1, $+\frac{1}{2}$
 (C) 5, 1, 0, $+\frac{1}{2}$ (D) 5, 1, 1, $+\frac{1}{2}$

Q.81 Match List I with List II.

List I (Spectral Series for Hydrogen)		List II (Spectral Region/Higher Energy State)	
(I)	Lyman	(P)	Infrared region
(II)	Balmer	(Q)	UV region
(III)	Paschen	(R)	Infrared region
(IV)	Pfund	(S)	Visible region

Choose the correct answer from the options given below: **[Main -2024]**

- (A) I-(P), II-(R), III-(Q), IV-(S)
 (B) I-(Q), II-(R), III-(P), IV-(S)
 (C) I-(P), II-(Q), III-(R), IV-(S)
 (D) I-(Q), II-(S), III-(R), IV-(P)

Q.82 Match List-I with List-II.

List-I Species		List-II Electronic distribution	
(I)	Cr^{+2}	(P)	$3d^8$
(II)	Mn^+	(Q)	$3d^3 4s^1$
(III)	Ni^{+2}	(R)	$3d^4$
(IV)	V^+	(S)	$3d^5 4s^1$

Choose the correct answer from the options given below : **[Main -2024]**

- (A) I-(Q), II-(P), III-(S), IV-(R)
 (B) I-(R), II-(S), III-(P), IV-(Q)
 (C) I-(S), II-(R), III-(P), IV-(Q)
 (D) I-(P), II-(Q), III-(R), IV-(S)

EXERCISE (Level-4)

Part-A : Multiple correct answer type questions

Q.1 Which of the following properties is/are proportional to the energy of the electromagnetic radiation ?

- (A) Frequency (B) Wave number
(C) Wavelength (D) Number of photons

Q.2 Which of the following statements are incorrect?

- (A) There are five unpaired electrons in (n - 1)d suborbit in Fe³⁺
(B) Fe³⁺, Mn²⁺ and Cr all having 24 electrons will have same value of magnetic moment
(C) Copper (I) chloride is coloured salt
(D) Every coloured ion is paramagnetic

Q.3 Which is not the correct orbital notation if the wave function is –

$$\psi = \frac{1}{81\sqrt{6\pi}} \left(\frac{1}{a_0} \right)^{3/2} \sigma^2 e^{-\sigma/3} (3\cos^2\theta - 1);$$

Here $\sigma = r/a_0$ and $a_0 = \frac{h^2 \epsilon_0}{\pi m e^2}$

- (A) 4s (B) 2P_x (C) 3P_y (D) 3d_{z²}

Q.4 Which of the following orbitals have no spherical nodes ?

- (A) 1s (B) 2s
(C) 2p (D) 3p

Q.5 In which of the following sets of orbitals, electrons have equal orbital angular momentum ?

- (A) 1s and 2s (B) 2s and 2p
(C) 2p and 3p (D) 3p and 3d

Q.6 Which of the following sets of quantum number are correct ?

- (A) $n = 3, \ell = 2, m = +1, s = +\frac{1}{2}$
(B) $n = 3, \ell = 3, m = +3, s = +\frac{1}{2}$
(C) $n = 4, \ell = 0, m = 0, s = -\frac{1}{2}$
(D) $n = 5, \ell = 2, m = +4, s = -\frac{1}{2}$

Q.7 Rutherford's experiment established that :

- (A) Inside the atom there is a heavy positive centre
(B) Nucleus contains protons and neutrons
(C) Most of the space in the atoms is empty
(D) Size of the nucleus is very small

Q.8 Which of the following statements are incorrect ?

- (A) For designating orbitals three quantum numbers are needed
(B) The second ionization energy of helium is 4 times, the first ionization of hydrogen
(C) The third ionization energy of lithium is 9 times, the first ionization of hydrogen
(D) Radius of third orbit of Li²⁺ is 3 times the radius of third orbit of hydrogen atom

Q.9 Which of the following statements (regarding an atom of H) are correct ?

- (A) Kinetic energy of the electron is maximum in the first orbit
(B) Potential energy of the electron is maximum in the first orbit
(C) Radius of the second orbit is four times the radius of the first orbit
(D) Various energy levels are equally spaced

Q.10 Which of the following transition in H-atom would result in emission of radiations of same frequency ?

- (A) 4s → 3p (B) 4d → 3p
(C) 5s → 4s (D) 3s → 2p

Q.11 The radial distribution functions [P(r)] is used to determine the most probable radius, which is used to find the electron in a given orbital

$$\frac{dP(r)}{dr} \text{ for 1s-orbital of hydrogen like atom}$$

having atomic number Z, is

$$\frac{dP}{dr} = \frac{4Z^3}{a_0^3} \left(2r - \frac{2Zr^2}{a_0} \right) e^{-2Zr/a_0}$$

Then which of the following statements is/are connect ?

(A) At the point of maximum value of radial

distribution function $\frac{dP(r)}{dr} = 0$; One

antinode is present

(B) Most probable radius of Li²⁺ is $\frac{a_0}{3}$ pm

(C) Most probable radius of He⁺ is $\frac{a_0}{2}$ pm

(D) Most probable radius of hydrogen atom is a_0 pm

- Q.12** Select the correct statement (s) -
 (A) An orbital with $\ell = 0$ is symmetrical about the nucleus
 (B) An orbital with $\ell = 0$ is spherically symmetrical about the nucleus
 (C) $3d_{z^2}$ is spherically symmetrical about the z-axis
 (D) All are correct

- Q.13** Select the correct statement (s) -
 (A) Radial function depends only on the direction, and is independent on quantum number n only the nucleus
 (B) Angular function depends only on the direction and is independent to the distance from the nucleus
 (C) $\Psi^2(r, \theta, \phi)$ is the probability density of finding the electron at a particular point in space
 (D) Radial distribution function ($4\pi r^2 R^2$) gives the probability of the electron being present at a distance r from the nucleus

- Q.14** Which is correct graph ?

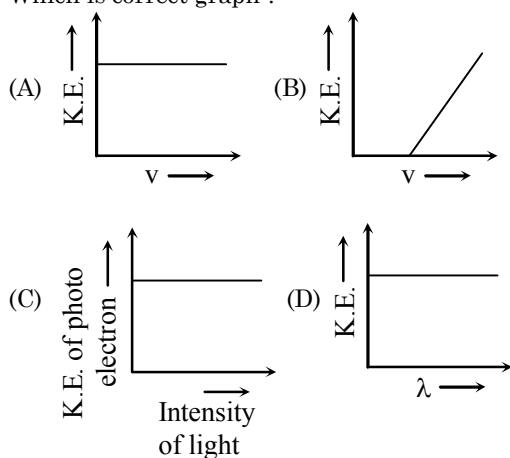

- Q.15** Select the correct curve (s) -
 If v = Velocity of electron in Bohr's orbit
 r = Radius of electron in Bohr's orbit
 P.E. = Potential energy of electron in Bohr's orbit
 K.E. = Kinetic energy of electron in Bohr's orbit

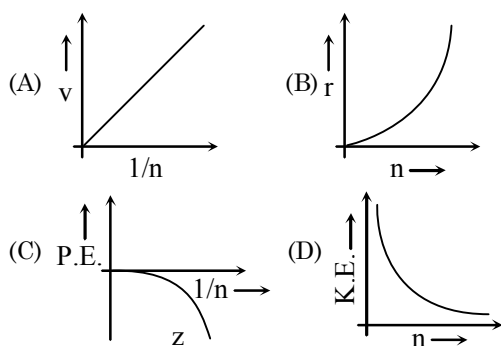

- Q.16** Select the correct statement(s) -
 (A) An electron near the nucleus is attracted by the nucleus and has a low potential energy
 (B) According to Bohr's theory, an electron continuously radiate energy if it stayed in one orbit
 (C) Bohr's model could not explain the spectra of multielectron atoms
 (D) Bohr's model was the first atomic model based on quantisation of energy

- Q.17** Choose the correct statement(s) -
 (A) The shape of an atomic orbital depends upon azimuthal quantum number
 (B) The orientation of an atomic orbital depends upon the magnetic quantum number
 (C) The energy of an electron in an atomic orbital of multi-electron atom depends upon principal quantum number only
 (D) The number of degenerate atomic orbital of one type depends upon the value of azimuthal and magnetic quantum number

- Q.18** For radial probability curves, which of the following is/are correct ?
 (A) The number of maxima in 2s orbital are two
 (B) The number of spherical or radial nodes is equal to $n-l-1$
 (C) The number of angular nodes are ' l '
 (D) $3d_{z^2}$ has 3 angular nodes

- Q.19** Select the correct statement(s) -
 (A) Radial distribution function indicates that there is a higher probability of finding the 3s electron close to the nucleus than in case of 3p and 3d electrons
 (B) Energy of 3s orbital is less than for the 3p and 3d orbitals
 (C) At the node, the value of the radial function changes from positive to negative
 (D) The radial function depends upon the quantum numbers n and l

- Q.20** Choose the incorrect statement(s) -
 (A) For a particular orbital in hydrogen atom, the wave function may have negative value
 (B) Radial probability distribution function though may have zero value but can never have negative value
 (C) $3d_{x^2-y^2}$ orbital has two angular nodes and one radial node
 (D) yz and xz planes are nodal planes for d_{xy} orbital

- Q.21** Select the correct statement(s) -
 (A) Heisenberg's principle is applicable to stationary e^-
 (B) Pauli's exclusion principle is not applicable to photons
 (C) For an e^- , the product of velocity and principal quantum number will be independent of principal quantum number
 (D) Quantum numbers l and m determine the value of angular wave function
- Q.22** Choose the correct statements among the following -
 (A) A node is a point in space where the wave-function Ψ has zero amplitude
 (B) The number of maxima (peaks) in radial distribution in $n-l$
 (C) Radial probability is $4\pi r^2 R_{n,\ell}^2(r)$
 (D) Ψ^2 represents probability of finding $3P_y$ orbital
- Q.23** Select the correct statement(s) regarding $3P_y$ orbital
 (A) Total no. of nodes are 2
 (B) Number of maxima in the curve $4\pi^2 R^2(r)$ Vs r is one
 (C) Quantum no. n , l and m for orbital may be, 3, 1, -1 respectively
 (D) The magnetic quantum number may have a positive value

Part-B : Assertion Reason type Questions

The following questions 24 to 27 consists of two statements each, printed as Assertion and Reason. While answering these questions you are to choose any one of the following four responses.

- (A) If both Assertion and Reason are true and the Reason is correct explanation of the Assertion.
 (B) If both Assertion and Reason are true but Reason is not correct explanation of the Assertion.
 (C) If Assertion is true but the Reason is false.
 (D) If Assertion is false but Reason is true
- Q.24** **Assertion** : The charge to mass ratio of the particles in anode rays depends on nature of the gas taken in the discharge tube.
Reason : The particles in anode rays carry positive charge.
- Q.25** **Assertion** : s-orbital cannot accommodate more than two electrons.
Reason : s-orbitals are spherically symmetrical.
- Q.26** **Assertion** : Kinetic energy of photoelectrons is directly proportional to the intensity of the incident radiation
Reason : Each photon of light causes the emission of only one photo electron.

- Q.27** **Assertion** : The existence of three unpaired electrons in phosphorous atom can be explained on the basis of Hund's rule.
Reason : According to Hund's rule, the degenerate orbitals are first singly occupied and only then pairing takes place.

Part-C : Column Matching type Questions

Q.28

Column-A		Column-B	
(A)	If P.E. = -13.6 eV	(i)	21
(B)	Ionization energy of electron from 2 nd shell of Na^{10+}	(ii)	10
(C)	Number of spectral lines when electron 7 th to 3 rd shell	(iii)	Total energy = -6.8 eV
(D)	Number of spectral lines when electron comes from 7 th shell to 1 st shell	(iv)	411.4 eV

Q.29

Column-A		Column-B	
(A)	Orbitals having equal energy	(i)	3p, 3d
(B)	Orbitals having zero orbital angular momentum	(ii)	2s and 3s
(C)	Orbitals with only one spherical node	(iii)	Degenerate orbitals
(D)	Orbitals having directional character	(iv)	2s and 3p

Q.30 Match the column :

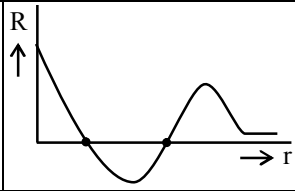
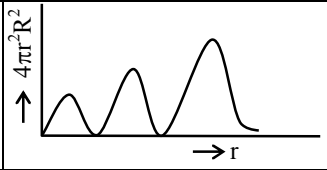
Column-A		Column-B	
(A)		(i)	$3p_z$
(B)		(ii)	$4p_y$
(C)	Angular probability is dependent on θ and ϕ	(iii)	3s
(D)	At least one angular node is present	(iv)	$3p_x$

Part-D : Passage based objective questions

Passage-1 (Ques. 31 to 33)

Electron moves around the nucleus in circular orbitals in fixed energy paths. As far as electron moves in these orbits neither energy is absorbed nor liberated. But when electron move from lower energy level to higher energy level energy is absorbed while when it comes back from higher energy level to lower energy level energy is liberated in the form of photon & a spectral line is formed. Corresponding to different possible transitions different lines are formed which form the particular series viz. Lyman, Balmer, Paschen, Brackett, Pfund, Humphrey etc. Suppose e^- in hydrogen atom is present in 10^{th} excited state, then answer the following questions based on paragraph :

- Q.31** If electron present in 10^{th} excited state liberate one visible quanta then next quanta liberated will correspond to following transition -
(A) $10 \rightarrow 2$ (B) $11 \rightarrow 2$
(C) $11 \rightarrow 1$ (D) $2 \rightarrow 1$
- Q.32** Total number of spectral lines which can be obtained during the transition to ground level -
(A) 45 (B) 55 (C) 66 (D) 36
- Q.33** Minimum value of wavelength that can be obtained during the transition -
(A) $\frac{121}{120R}$ (B) $\frac{11}{10R}$ (C) $\frac{100}{99R}$ (D) $\frac{10}{9R}$

Where R is Rydberg constant.

Passage-2 (Ques. 34 to 36)

Suppose Bohr theory is applicable to a negatively charged particle of mass $2m_e$ and charge $2e$ revolving around the nucleus of positive charge Ze . Let r_1, v_1 and E_1 be the radius of the orbit speed of the particle in the orbit and energy of the particle in the orbit respectively. The values for the electron revolving in the corresponding orbit are r, v and E respectively.

- Q.34** Which of the following expression regarding the ratio of radii is correct ?
(A) $\frac{r_1}{r} = 2$ (B) $r_1/r = \frac{1}{2}$
(C) $\frac{r_1}{r} = 4$ (D) $\frac{r_1}{r} = \frac{1}{4}$
- Q.35** Which of the following expression regarding the ratio of speeds is correct?
(A) $\frac{v_1}{v} = 2$ (B) $\frac{v_1}{v} = \frac{1}{2}$
(C) $\frac{v_1}{v} = 4$ (D) $\frac{v_1}{v} = \frac{1}{4}$

- Q.36** Which of the following expression regarding the ratio of energies is correct ?

(A) $\frac{E_1}{E} = 4$ (B) $\frac{E_1}{E} = \frac{1}{4}$
(C) $\frac{E_1}{E} = 8$ (D) $\frac{E_1}{E} = \frac{1}{8}$

Passage-3 (Ques. 37 to 39)

Assume that there were four possible values

$(-1, \frac{1}{2}, +\frac{1}{2}, +1)$ for the spin quantum number

m_s . Principal quantum number n is defined as usual. However, quantum number ℓ & m_ℓ are defined as follows :

ℓ : 1 to $(n+1)$ in integral steps

m_ℓ : $-\ell/2$ to $+\ell/2$ (including zero, if any) in integral steps.

The orbitals corresponding to $\ell = 1, 2, 3, \dots$ designated as A, B, C,.....respectively. Further, the values of m_ℓ for a given value of ℓ give the number of sub-orbitals in an orbital.

The principles for filling electrons in the shells remain unchanged. The order of energies of various orbitals is : $A < B < C, \dots$ for the same shell.

- Q.37** The second period would begin with -
(A) Fluorine (B) Sodium
(C) Calcium (D) Scandium
- Q.38** If Aufbau's principle is not to be violated i.e. $(n + \ell)$ rule must be followed, the outermost electronic configuration of an element with at. no. 100 would be -
(A) $3B^8 4A^4$ (B) $3C^{16} 4A^8$
(C) $3C^{12} 4B^8$ (D) $4B^{12} 5A^8$
- Q.39** The number of sub-orbitals & the maximum number of electrons that can be filled in an E-orbitals are respectively -
(A) 6, 24 (B) 5, 20
(C) 7, 28 (D) can't be determined

Passage-4 (Q.40 to Q.42)

Orbital wave function Ψ can

be given as

$$\Psi(r, \theta, \phi) = R(r) \cdot \theta(\theta) \cdot \phi(\phi)$$

For various orbitals of H-atom and H-like atoms values of R (radial wave function) are

For 1s-orbital : $R_{1s} = 2 \left(\frac{z}{a_0} \right)^{3/2} e^{-zr/a_0}$

For 2s-orbital :

$$R_{2s} = \left(\frac{z}{2a_0} \right)^{3/2} \left(2 - \frac{zr}{a_0} \right) e^{-zr/2a_0}$$

For 1p-orbital

$$R_{2p} = \frac{1}{\sqrt{3}} \left(\frac{z}{2a_0} \right)^{3/2} \left(\frac{zr}{a_0} \right) e^{-zr/2a_0}$$

For 3s-orbital

$$R_{3s} = \frac{2}{3} \left(\frac{z}{3a_0} \right)^{3/2} \left(3 - \frac{2zr}{a_0} + \frac{2z^2 r^2}{9a_0^2} \right) \times e^{-zr/3a_0}$$

etc. Here $a_0 = \text{bohr radius} = \frac{4\pi\epsilon_0 \hbar^2}{\mu e^2}$

$z = \text{atomic number}$

Similarly angular functions θ and ϕ can also be given

For s-orbital θ and ϕ can be given as

$$\theta(\theta) = \frac{1}{\sqrt{2}} \quad \text{and} \quad \phi(\phi) = \frac{1}{\sqrt{2\pi}}$$

So for 1s-orbital Ψ can be given as -

$$\Psi_{1s} = R_{1s} \cdot \theta_{1s} \cdot \phi_{1s}$$
$$= \frac{1}{\sqrt{\pi}} \left(\frac{z}{a_0} \right)^{3/2} e^{-zr/a_0}$$

Q.40 Probability density of finding an electron at distance r from nucleus in H-atom (in ground state) is -

- (A) Ψ (B) R^2
(C) $\frac{1}{\pi} \left(\frac{z}{a_0} \right)^3 e^{-2zr/a_0}$ (D) None of these

Q.41 Value of r at which radial node is found for 2s-orbital is -

- (A) a_0 (B) $2a_0$ (C) $3a_0$ (D) $4a_0$

Q.42 Radial nodes for 3s-orbital is/are at -

- (A) $r = 1.9 a_0$ (B) $r = 7.1 a_0$
(C) $r = 2a_0$ (D) Both (A) and (B)

Part-E : Numeric Response Type Questions

Q.43 The line at 434 nm in the Balmer series of the hydrogen spectrum corresponds to a transition of an electron from the n^{th} to second Bohr orbit. What is the value of n ?

Q.44 A particle of charge equal to that of an electron and mass 400 times the mass of the electron moves in a circular orbit around the nucleus of charge $+4e$. Assuming that the Bohr model of the atom is applicable to this system find the value of n for which the

Part-F : Subjective Type Questions

Q.45 When would the wavelength associated with an electron be equal to wavelength of proton?
(mass of $e = 9 \times 10^{-28} \text{ g}$;
mass of proton = $1.6725 \times 10^{-24} \text{ g}$)

Q.46 Point out the angular momentum of an electron in
(a) 4s orbital (b) 3p orbital
(c) 4th orbit

Q.47 (a) The wave number of the first line in the Balmer series of Be^{3+} is $2.43 \times 10^5 \text{ cm}^{-1}$. What is the wave number of the second line of the Paschen series of Li^{2+} ?
(b) In ions like He^+ , Li^{2+} , Be^{3+} how and why does the value of the Rydberg constant vary ?

Q.48 Calculate the wavelength in \AA of the photon that is emitted when an electron in Bohr orbit with $n = 2$ returns to orbit with $n = 1$ in H atom. The ionisation potential of the ground state of H-atom is $2.17 \times 10^{-11} \text{ erg}$.

Q.49 Two particles A and B are in motion. If the wavelength associated with the particle A is $5 \times 10^{-8} \text{ m}$, calculate the wavelength of particle B if its momentum is half of A.

Q.50 The first ionization energy of H is $21.79 \times 10^{-19} \text{ J}$. Determine the second ionization energy of He atom.

Q.51 How many times larger is the spacing between the energy levels with $n = 3$ and $n = 8$ spacing between the energy level with $n = 8$ and $n = 9$ for the hydrogen atom ?

Q.52 Calculate the minimum uncertainty in velocity of a particle of mass $1.1 \times 10^{-27} \text{ kg}$ if uncertainty in its position is $3 \times 10^{-10} \text{ cm}$.

Q.53 Calculate the number of photons emitted in 10 hours by a 60 W sodium lamp.
($\lambda_{\text{photon}} = 5893 \text{ \AA}$).

Q.54 Calculate total spin, magnetic moment for the atoms having atomic number 7, 24, 34 and 36.

Q.55 Magnetic moment of X^{3+} ion of 3d series is $\sqrt{35} \text{ B.M.}$ What is atomic number of X^{3+} ?

Q.56 When a certain metal was irradiated with light of frequency $3.2 \times 10^{16} \text{ Hz}$, the photoelectrons emitted had twice the kinetic energy as did photoelectrons emitted when the same metal was irradiated with light of frequency $2.0 \times 10^{16} \text{ Hz}$. Calculate v_0 for the metal.

Q.57 Calculate the circumference of the 4th Bohr orbit for an electron travelling with a velocity of $2.19 \times 10^6 \text{ m/s}$.

Q.58 1.53 g of hydrogen is excited by irradiation. At a certain instant, 10% of the atoms are at the excited level of energy -328 kJ mol^{-1} and 2% of the atoms are at the excited level of energy $-146 \text{ kJ mole}^{-1}$. The remaining atoms are in the ground state. Calculate how much energy will be evolved when all the excited atoms return to the ground state.

- Q.59** Electrons of energy 12.1 eV are fired at the hydrogen atom in a gas discharge tube. Determine the wavelength of the lines that can be emitted by hydrogen.
- Q.60** Calculate the angular frequency ($\omega = v/r$) of an electron occupying the second Bohr orbit of He^+ ion.
- Q.61** A single electron atom has nuclear charge $+Ze$ where Z is atomic number and e is electronic charge. It requires 47.2 eV to excite the electron from the second Bohr orbit to third Bohr orbit. Find.
- The atomic number of element.
 - The energy required for transition of electron from third to fourth orbit.
 - The wavelength required to remove electron from first Bohr orbit to infinity.
 - The kinetic energy of electron in first Bohr orbit.
- Q.62** The de Broglie wavelength of electron of He^+ ion is 3.329 Å. If the photon emitted upon de-excitation of this He^+ ion is made to hit H-atom in its ground state so as to liberate electron from it, what will be the de-Broglie's wavelength of photoelectron.
- Q.63** The subshell that arises after f is called g subshell.
- How many g orbitals are present in the g subshell ?
 - In what principal electronic shell would the g subshell first occur and what is the total number of orbitals in this principal shell ?
- Q.64** What is the speed of an electron whose de Broglie's wavelength is 1 nm ?

EXERCISE (Level-5)

Old Examination Questions [JEE Advanced]

Q.1 The number of radial nodal surface in 3s and 2p
[IIT-2005]
(A) 2, 0 (B) 2, 1 (C) 1, 0 (D) 0, 2

Q.2 Give answer : [IIT-2005]
(a) For first orbit of hydrogen atom, calculate the velocity of electron ($r = a_0 = 0.529 \text{ \AA}$)
(b) Calculate the de-broglie wavelength of electron in first Bohr orbit
(c) Calculate the orbital angular momentum of 2p orbital in terms of $h/2\pi$ units

Q.3 According to Bohr's theory, [IIT-2006]
 E_n = Total energy ;
 K_n = Kinetic energy
 V_n = Potential energy
 r_n = Radius of n^{th} orbit
Match the following :

Column-I		Column-II	
(A)	$V_n/K_n = ?$	(P)	0
(B)	If radius of n^{th} orbital is r_n , $r_n \propto E_n^x$, $x = ?$	(Q)	-1
(C)	Angular momentum in lowest orbital	(R)	-2
(D)	$\frac{1}{r^n} \propto Z^y$, $y = ?$	(S)	1

Q.4 Match the entries in column-I with the correctly related quantum no. (s) in column-II [IIT-2008]

Column-I		Column-II	
(A)	orbital angular momentum of the electron in a hydrogen like atomic orbital	(P)	Principal quantum number
(B)	A hydrogen like one electron wave function obeying Pauli's number principle	(Q)	Azimuthal quantum number
(C)	Shape, size and orientation of hydrogen like atomic orbital	(R)	magnetic quantum number
(D)	Probability density of electron at the nucleus in hydrogen like atom	(S)	Electron spin quantum number

Passage based objective questions

Passage :1 (Ques. 5 to 7)

The hydrogen like species Li^{2+} is in a spherically symmetric state S_1 with one radial node. Upon absorbing light the ion undergoes transition to a state S_2 . The state S_2 has one radial node and its energy is equal to the ground state energy of the hydrogen atom. [IIT-2010]

Q.5 The state S_1 is -
(A) 1s (B) 2s (C) 2p (D) 3s

Q.6 Energy of the state S_1 in units of the hydrogen atom ground state energy is -
(A) 0.75 (B) 1.50 (C) 2.25 (D) 4.50

Q.7 The orbital angular momentum quantum number of the state S_2 is -
(A) 0 (B) 1 (C) 2 (D) 3

Q.8 The maximum number of electrons that can have principal quantum number, $n = 3$ and spin quantum number, $m_s = -1/2$, is. [IIT-2011]

Q.9 The work function (ϕ) of some metals is listed below. The number of metals which will show photoelectric effect when light of 300 nm wavelength falls on the metal is. [IIT-2011]

Metal	Li	Na	K	Mg	Cu	Ag	Fe	Pt	W
ϕ (eV)	2.4	2.3	2.2	3.7	4.8	4.3	4.7	6.3	4.75

Q.10 The kinetic energy of an electron in the second Bohr orbit of a hydrogen atom is [a_0 is Bohr radius] [IIT-2012]

(A) $\frac{h^2}{4\pi^2 ma_0^2}$ (B) $\frac{h^2}{16\pi^2 ma_0^2}$
(C) $\frac{h^2}{32\pi^2 ma_0^2}$ (D) $\frac{h^2}{64\pi^2 ma_0^2}$

Q.11 In an atom, the total number of electrons having quantum numbers $n = 4$, $|m_l| = 1$ and $m_s = -1/2$ is [JEE-Advance-2014]

Q.12 Not considering the electronic spin, the degeneracy of the second excited state ($n = 3$) of H atom is 9, while the degeneracy of the second excited state of H^- is - [JEE-Advance-2015]

Q.13 P is the probability of finding the 1s electron of hydrogen atom in a spherical shell of infinitesimal thickness, dr , at a distance r from the nucleus. The volume of this shell is $4\pi r^2 dr$. The qualitative sketch of the dependence of P on r is- [JEE-Advance-2016]

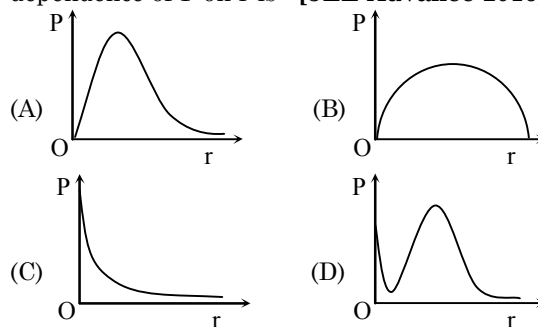

Passage - 2 : Answer Q.14, Q.15 and Q.16 by appropriately matching the information given in the three columns of the following table [JEE-Advance-2017]

The wave function, Ψ_{n,ℓ,m_1} is a mathematical function whose value depends upon spherical polar coordinates (r, θ, ϕ) of the electron and characterized by the quantum numbers n, ℓ and m_1 . Here r is distance from nucleus, θ is colatitude and ϕ is azimuth. In the mathematical functions given in the Table, Z is atomic number and a_0 is Bohr radius

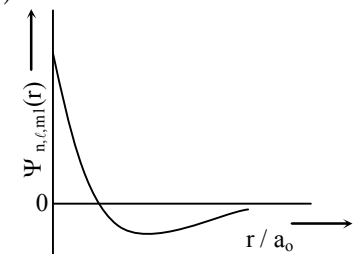
Column 1	Column 2	Column 3
(I) 1s orbital	(i) $\Psi_{n,\ell,m_1} \propto \left(\frac{Z}{a_0}\right)^{\frac{3}{2}} e^{-\left(\frac{Zr}{a_0}\right)}$	(P) 
(II) 2s orbital	(ii) One radial node	(Q) Probability density at nucleus $\propto \frac{1}{a_0^3}$
(III) 2p _z orbital	(iii) $\Psi_{n,\ell,m_1} \propto \left(\frac{Z}{a_0}\right)^{\frac{5}{2}} r e^{-\left(\frac{Zr}{2a_0}\right)} \cos \theta$	(R) Probability density is maximum at nucleus
(IV) 3d _{z²} orbital	(iv) xy- plane is a nodal plane	(S) Energy needed to excite electron from $n = 2$ state to $n = 4$ state is $\frac{27}{32}$ times the energy needed to excite electron from $n = 2$ state to $n = 6$ state

Q.14 For the given orbital in Column 1, the only **CORRECT** combination for any hydrogen-like species is

- (A) (III) (iii) (P) (B) (II) (ii) (P)
 (C) (IV) (iv) (R) (D) (I) (ii) (S)

Q.15 For He⁺ ion, the only **INCORRECT** combination is

- (A) (I) (i) (R) (B) (I) (i) (S)
 (C) (I) (iii) (R) (D) (II) (ii) (Q)

Q.16 For hydrogen atom, the only **CORRECT** combination is

- (A) (I) (i) (S) (B) (I) (iv) (R)
 (C) (I) (i) (P) (D) (II) (i) (Q)

Q.17 At 143 K, the reaction of XeF₄ with O₂F₂ produces a xenon compound Y. The total number of lone pair(s) of electron present on the whole molecule of Y is ____ [JEE-Advanced-2019]

Q.18 The ground state energy of hydrogen atom is -13.6 eV. Consider an electronic state ψ of He⁺ whose energy, azimuthal quantum number and magnetic quantum number are -3.4 eV, 2 and 0, respectively. Which of the following statement(s) is(are) true for the state ψ ?

MCQ [JEE-Advanced-2019]

(A) The nuclear charge experienced by the electron in this state is less than $2e$, where e is the magnitude of the electronic charge

- (B) It has 2 angular nodes
 (C) It has 3 radial nodes
 (D) It is a 4d state

Q.19 Consider the Bohr's model of a one-electron atom where the electron moves around the nucleus. In the following, List-I contains some quantities for the n^{th} orbit of the atom and List-II contains options showing how they depend on n .

[JEE-Advanced-2019]

LIST-I

LIST-II

- (I) Radius of the n^{th} orbit (P) $\propto n^{-2}$
 (II) Angular momentum of the electron in the n^{th} orbit (Q) $\propto n^{-1}$
 (III) Kinetic energy of the electron in the n^{th} orbit (R) $\propto n^0$
 (IV) Potential energy of the electron in the n^{th} orbit (S) $\propto n^1$

(T) $\propto n^2$

(U) $\propto n^{1/2}$

(A) (III), (P)

(B) (III), (S)

(C) (IV), (U)

(D) (IV), (Q)

- Q.20** Consider the Bohr's model of a one-electron atom where the electron moves around the nucleus. In the following, List-I contains some quantities for the n^{th} orbit of the atom and List-II contains options showing how they depend on n .
[JEE-Advanced-2019]

LIST-I

- (I) Radius of the n^{th} orbit
(II) Angular momentum of the electron in the n^{th} orbit
(III) Kinetic energy of the electron in the n^{th} orbit
(IV) Potential energy of the electron in the n^{th} orbit

LIST-II

- (P) $\propto n^{-2}$
(Q) $\propto n^{-1}$
(R) $\propto n^0$
(S) $\propto n^1$
(T) $\propto n^2$
(U) $\propto n^{1/2}$

- (A) (I), (P) (B) (I), (T)
(C) (II), (R) (D) (II), (Q)

- Q.21** The figure below is the plot of potential energy verses internuclear distance (d) of H_2 molecule in the electronic ground state. What is the value of the net potential energy E_0 (as indicated in the figure) in kJ mol^{-1} , for $d = d_0$ at which the electron-electron repulsion and the nucleus-nucleus repulsion energies are absent? as reference, the potential energy of H atom is taken as zero when its electron and the nucleus are infinitely far apart.

Use Avogadro constant as $6.023 \times 10^{23} \text{ mol}^{-1}$
[JEE-Advanced-2020]

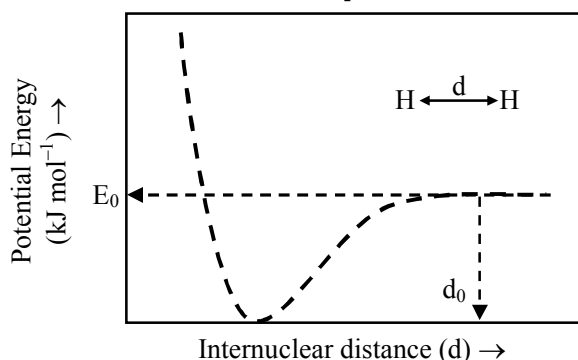

- Q.22** Consider a helium (He) atom that absorbs a photon of wavelength 330 nm. The change in the velocity (in cm s^{-1}) of He atom after the photon absorption is _____.

(Assume : Momentum is conserved when photon is absorbed.)

Use : Planck constant = $6.6 \times 10^{-34} \text{ J s}$,
Avogadro number = $6 \times 10^{23} \text{ mol}^{-1}$, Molar mass of He = 4 g mol^{-1}
[JEE-Advanced-2021]

- Q.23** For diatomic molecules, the correct statement(s) about the molecular orbitals formed by the overlap of two $2p_z$ orbitals is (are)

[JEE-Advanced-2022]

- (A) σ orbital has a total of two nodal planes.
(B) σ^* orbital has one node in the x-z plane containing the molecular axis.
(C) π orbital has one node in the plane which is perpendicular to the molecular axis and goes through the center of the molecule.
(D) π^* orbital has one node in the xy-plane containing the molecular axis.

- Q.24** For He^+ , a transition takes place from the orbit of radius 105.8 pm to the orbit of radius 26.45 pm. The wavelength (in nm) of the emitted photon during the transition is ____.

[Use: Bohr radius, $a = 52.9 \text{ pm}$; Rydberg constant, $R_H = 2.2 \times 10^{-18} \text{ J}$; Planck's constant, $h = 6.6 \times 10^{-34} \text{ J s}$; Speed of light, $c = 3 \times 10^8 \text{ m s}^{-1}$]

[JEE-Advanced-2023]

- Q.25** Among the following, the correct statement(s) for electrons in an atom is(are)

[JEE-Advanced-2024]

- (A) Uncertainty principle rules out the existence of definite paths for electrons.
(B) The energy of an electron in 2s orbital of an atom is lower than the energy of an electron that is infinitely far away from the nucleus.
(C) According to Bohr's model, the most negative energy value for an electron is given by $n = 1$, which corresponds to the most stable orbit.
(D) According to Bohr's model, the magnitude of velocity of electrons increases with increase in values of n .

- Q.26** According to Bohr's model, the highest kinetic energy is associated with the electron in the :

[JEE-Advanced-2024]

- (A) first orbit of H atom
(B) first orbit of He^+
(C) second orbit of He^+
(D) second orbit of Li^{2+}

EXERCISE (Level-6)

Review Exercise

- Q.1** An electron is accelerated from a very low velocity (\sim zero speed) by the application of a potential difference of V volts. If the de Broglie wavelength should change (i.e., decrease) by 1.0% what percent increase in V causes it-
- Q.2** An electron first accelerated through 100 volts suffers successively two retardations (i) through 19 volts and then (ii) through 32 volts. Its de Broglie wavelengths in the three situations are respectively λ_1 , λ_2 and λ_3 . Calculate $\frac{\lambda_3 - \lambda_2}{\lambda_1}$.
- Q.3** Photons having energy equivalent to binding energy of 2nd state of Li^+ ion are used at metal surface of work function 10.6 eV. If the ejected electrons are further accelerated through the potential difference of 5 V then the minimum value of de-Broglie wavelength associated with the electron is -
- Q.4** A hydrogen atom in its ground state absorbs a photon and goes into the first excited state. It then absorbs a second photon which just ionizes it. What is the ratio of the wavelengths of the first photon and the second photon ?
- Q.5** A hydrogen like atom with atomic number 'Z' is in higher excited state of quantum number 'n'. This excited state atom can make a transition to the first excited state by successively emitting two photons of energies 10 eV and 17 eV respectively. Alternatively, the atom from the same excited state can make a transition to the 2nd excited state by emitting two photons of energies 4.25 eV and 5.95 eV respectively. The 'n' and 'Z' are-
- Q.6** The Schrodinger wave equation for hydrogen atom is
- $$\Psi(\text{radial}) = \frac{1}{16\sqrt{4}} \left(\frac{Z}{a_0} \right)^{3/2} [(\sigma - 1)(\sigma^2 - 8\sigma + 12)] e^{-\sigma/2}$$
- where a_0 and Z are the constant in which answer can be expressed and $\sigma = \frac{2Zr}{a_0}$
- minimum and maximum position of radial nodes from nucleus are.....respectively.
- Q.7** For a hypothetical hydrogen like atom, the potential energy of the system is given by $U(r) = \frac{-Ke^2}{r^3}$, where r is the distance between the two particles. If Bohr's model of quantization of angular momentum is applicable then velocity of particle is given by:
- Q.8** An element undergoes a reaction as shown: $X + 2e^- \rightarrow X^{2-}$, energy released = 30.87 eV/atom. If the energy released, is used to dissociate 4 gms of H_2 molecules, equally into H^+ and H^* , where H^* is excited state of H atoms where the electron travels in orbit whose circumference equal to four times its de Broglie's wavelength. Determine the least moles of X that would be required: Given: I.E. of H = 13.6 eV/atom, bond energy of H_2 = 4.526 eV/molecule
- Q.9** In a measurement of quantum efficiency of photosynthesis in green plants, it was found that 10 quanta of red light of wavelength 6850 Å were needed to release one molecule of O_2 . The average energy storage in this process is 112 kcal/mol O_2 evolved. What is the energy conversion efficiency in this experiment ? Given: 1 cal = 4.18 J; $N_A = 6 \times 10^{23}$; $h = 6.63 \times 10^{-34}$ J. s
- Q.10** Find the value of wave number ($\bar{\nu}$) in terms of Rydberg's constant, when transition of electron takes place between two levels of He^+ ion whose sum is 4 and difference is 2.

ANSWER KEY

EXERCISE (Level-1)

- | | | | | | | |
|---------|---------|---------|---------|---------|---------|---------|
| 1. (C) | 2. (A) | 3. (C) | 4. (B) | 5. (B) | 6. (C) | 7. (C) |
| 8. (A) | 9. (B) | 10. (D) | 11. (D) | 12. (A) | 13. (D) | 14. (D) |
| 15. (B) | 16. (C) | 17. (D) | 18. (B) | 19. (C) | 20. (C) | 21. (A) |
| 22. (D) | 23. (D) | 24. (C) | 25. (C) | 26. (A) | 27. (D) | 28. (A) |
| 29. (D) | 30. (C) | 31. (A) | 32. (C) | 33. (C) | 34. (A) | 35. (C) |
| 36. (C) | 37. (C) | 38. (B) | 39. (A) | 40. (A) | | |

EXERCISE (Level-2)

- | | | | | | | |
|---------|---------|---------|-----------|---------|---------|---------|
| 1. (D) | 2. (A) | 3. (A) | 4. (D) | 5. (C) | 6. (B) | 7. (D) |
| 8. (A) | 9. (B) | 10. (D) | 11. (C) | 12. (C) | 13. (A) | 14. (A) |
| 15. (D) | 16. (A) | 17. (A) | 18. (C) | 19. (A) | 20. (D) | 21. (C) |
| 22. (B) | 23. (A) | 24. (B) | 25. (C) | 26. (D) | 27. (B) | 28. (A) |
| 29. (D) | 30. (A) | 31. (C) | 32. (B) | 33. (C) | 34. (D) | 35. (D) |
| 36. (C) | 37. (C) | 38. (B) | 39. (B,C) | 40. (C) | 41. (A) | 42. (B) |
| 43. (A) | 44. (C) | 45. (A) | 46. (D) | 47. (A) | 48. (C) | 49. (A) |
| 50. (B) | 51. (A) | 52. (C) | 53. (C) | 54. (A) | 55. (B) | 56. (A) |
| 57. (D) | 58. (A) | 59. (D) | 60. (B) | 61. (C) | 62. (A) | 63. (A) |
| 64. (C) | 65. (D) | 66. (B) | 67. (D) | 68. (B) | 69. (B) | 70. (C) |
| 71. (C) | 72. (C) | 73. (D) | 74. (D) | 75. (B) | 76. (C) | 77. (C) |
| 78. (D) | 79. (B) | | | | | |

EXERCISE (Level-3)

- | | | | | | | |
|------------|------------|---------|---------|---------|---------|-------------|
| 1. (C) | 2. (D) | 3. (C) | 4. (B) | 5. (B) | 6. (C) | 7. (C) |
| 8. (B) | 9. (C) | 10. (A) | 11. (A) | 12. (C) | 13. (B) | 14. (B) |
| 15. (B) | 16. (A) | 17. (C) | 18. (A) | 19. (B) | 20. (B) | 21. (C) |
| 22. (D) | 23. (B) | 24. (D) | 25. (D) | 26. (A) | 27. (C) | 28. (C) |
| 29. (C) | 30. (D) | 31. (B) | 32. (C) | 33. (B) | 34. (B) | 35. (D) |
| 36. (D) | 37. (D) | 38. (B) | 39. (B) | 40. (B) | 41. (B) | 42. (C) |
| 43. (B) | 44. (B) | 45. (A) | 46. (C) | 47. (B) | 48. (D) | 49. (C) |
| 50. (A) | 51. (B) | 52. (A) | 53. (C) | 54. (B) | 55. (C) | 56. (A) |
| 57. (D) | 58. (C) | 59. (C) | 60. (D) | 61. (C) | 62. (B) | 63. (D) |
| 64. (C) | 65. (D) | 66. (B) | 67. (D) | 68. (D) | 69. (A) | 70. [22.00] |
| 71. [2.00] | 72. [4.00] | 73. (B) | 74. (A) | 75. (C) | 76. (C) | 77. (5) |
| 78. (16) | 79. (C) | 80. (A) | 81. (D) | 82. (B) | | |

EXERCISE (Level-4)

Part-A

- | | | | | | | |
|--------------|---------------|-------------|---------------|-------------|-------------|-------------|
| 1. (A,B,D) | 2. (B,C,D) | 3. (A,B,C) | 4. (A,C) | 5. (A,C) | 6. (A,C) | 7. (A,C,D) |
| 8. (D) | 9. (A,C) | 10. (A,B) | 11. (A,B,C,D) | 12. (A, B) | 13. (B,C,D) | 14. (B,C) |
| 15. (A,B) | 16. (A,C,D) | 17. (A,B,D) | 18. (A,B,C) | 19. (A,C,D) | 20. (B,C) | 21. (B,C,D) |
| 22. (AB,C,D) | 23. (A,B,C,D) | | | | | |

Part-B

- | | | | |
|---------|---------|---------|---------|
| 24. (B) | 25. (B) | 26. (D) | 27. (A) |
|---------|---------|---------|---------|

Part-C

- | | | | |
|----------------|------------------|-----------------|---------------------|
| 28. A → (iii); | B → (iv); | C → (ii); | D → (i) |
| 29. A → (iii); | B → (ii); | C → (iv); | D → (i) |
| 30. A → (iii); | B → (ii), (iii); | C → (ii), (iv); | D → (i), (ii), (iv) |

Part-D

31. (D) 32. (B) 33. (A) 34. (D) 35. (A) 36. (C) 37. (D)
38. (B) 39. (A) 40. (C) 41. (B) 42. (D)

Part-E

43. $n = 5$ 44. $n = 40$

Part-F

45. $\frac{v_e}{v_p} = 1.858 \times 10^3$ 46. (a) 0 (b) $\frac{h}{\sqrt{2}\pi}$ (c) $\frac{2h}{\pi}$
47. (a) $7 \times 10^6 \text{ m}^{-1}$ (b) $R_H = R_H Z^2$
48. 1221 Å 49. $10 \times 10^{-8} \text{ m}$ 50. $87.16 \times 10^{-19} \text{ J}$
51. 3.235 52. $1.598 \times 10^{-4} \text{ m/sec.}$ 53. 6.4×10^{24}
54. Total spin = $\pm 3/2, \pm 3, \pm 1, 0$; magnetic moment = $\sqrt{15}, \sqrt{48}, \sqrt{8}, 0$ 55. 26
56. $8 \times 10^{15} \text{ Hz}$ 57. $13.297 \times 10^{-10} \text{ m}$ 58. 184.2 kJ
59. 1212 Å, 1022 Å, 5545 Å 60. $2.067 \times 10^{16} \text{ sec}^{-1}$
61. (a) 5 ; (b) $23.9 \times 10^{-19} \text{ J}$; (c) 36.5 Å ; (d) $5.45 \times 10^{-10} \text{ erg}$ 62. 2.351 Å
63. (a) 9 (b) 25 64. $7.36 \times 10^5 \text{ m/s}$

EXERCISE (Level-5)

1. (A) 2. (a) $2.18 \times 10^8 \text{ cm/sec}$ (b) 3.3 Å (C) $\sqrt{2} \frac{h}{2\pi}$ 3. $a \rightarrow R$; $b \rightarrow Q$; $c \rightarrow P$; $d \rightarrow S$
4. $a \rightarrow Q, R$; $b \rightarrow P, Q, R, S$; $c \rightarrow P, Q, R$; $d \rightarrow P, Q$
5.(B) 6.(C) 7.(B) 8.[9] 9.[4] 10. (C) 11. [6]
12. [3] 13. (A) 14.(B) 15.(C) 16.(A) 17. [19.00] 18. (B,D)
19. (A) 20. (B) 21. [-5246.50] 22. [30] 23. (A, D) 24. [30] 25. (A, B, C)
26. (B)

EXERCISE (Level-6)

1. $V = 2\%$ 2. $\frac{20}{63}$ 3. 2.45 Å 4. 0.33 5. $n \approx 6$
6. $r_1 = \frac{a_0}{2Z}, \frac{a_0}{Z}, \frac{3a_0}{Z}$ 7. $v = \frac{n^3 h^3}{24Ke^2 \pi^3 m^2}$ 8. 2 9. 26.9% 10. $\frac{32R}{9}$

STUDY MATERIAL

JEE

FOR MAIN & ADVANCED

MATHEMATICS



 CP PUBLICATION

MATHEMATICS

Study Material for JEE Main & Advanced preparation
Prepared by Career Point Kota Experts



CAREER POINT

CONTENTS OF THE PACKAGE AT A GLANCE

MATHEMATICS

Class 11

Trigonometry

- ◆ Trigonometric Ratios
- ◆ Trigonometric Equations
- ◆ Properties of Triangle
- ◆ Radii of Circle

Algebra (Part-I)

- ◆ Elementary Mathematics & Logarithm
- ◆ Quadratic Equation
- ◆ Progressions
- ◆ Binomial Theorem
- ◆ Permutation & Combination
- ◆ Statistics
- ◆ Set & Relation

Coordinate Geometry

- ◆ Point & Straight Line
- ◆ Circle
- ◆ Parabola
- ◆ Ellipse
- ◆ Hyperbola

Class 12

Differential Calculus

- ◆ Function
- ◆ Inverse Trigonometric Functions
- ◆ Limit
- ◆ Continuity
- ◆ Differentiation
- ◆ Tangent & Normal
- ◆ Monotonicity
- ◆ Maxima & Minima

Integral Calculus

- ◆ Indefinite Integration
- ◆ Definite Integration
- ◆ Area Under the Curve
- ◆ Differential Equation

Algebra (Part-II)

- ◆ Complex Number
- ◆ Probability
- ◆ Determinants
- ◆ Matrices
- ◆ Vector
- ◆ Three Dimensional Geometry

Note to the Students

Career Point offers this must have Study Package in Physics to meet the complete curriculum needs of engineering aspirants. The set comprises of 6 books: **Mathematics** - set of 3 books for class 11 and set of 3 books for Class 12. The set caters to the different requirements of students in classes XI and XII. It offers complete and systematic coverage of **JEE Main** and **JEE Advanced** syllabi and aims to provide firm foundation in learning and develop competitive edge in preparation of the JEE and other engineering entrance examinations.

COMPONENTS OF EACH CHAPTER

These books are designed with an engaging and preparation-focused pedagogy and offer a perfect balance of conceptual learning and problem solving skills.

Theory & Concepts

Each chapter consists of high quality theory that covers all the topics, sub-topics and concepts of JEE syllabus.

Function

1. PRELIMINARIES

◆ Tricotomy Law

The real numbers are ordered in magnitude means. If x and y be two real numbers then there will be one and only one of the following relation will hold.

$$x < y, x = y, x > y$$

◆ Interval

The set of numbers between any two real numbers is called interval. The following are the types of interval.

(a) Closed Interval

$$[a, b] = \{x, a \leq x \leq b\}$$

(b) Open Interval

$$(a, b) \text{ or }]a, b[= \{x, a < x < b\}$$

(c) Semi open or semi closed interval

$$[a, b[\text{ or }]a, b] = \{x; a \leq x < b\}$$

$$]a, b] \text{ or } (a, b] = \{x; a < x \leq b\}$$

2. DEFINITION OF FUNCTION

Let A and B be two non-empty sets. Then a function ' f ' from set A to set B is a rule which associates elements of set A to elements of set B such that

- All elements of set A are associated to element in set B .
- An element of set A is associated to a unique element in set B .

Terms such as "map" (or "mapping"), "correspondence" are used as synonyms for "function". If f is a function from a set A to set B , then we write $f: A \rightarrow B$ or $A \xrightarrow{f} B$, which is read as f is a function from A to B or f maps A to B .

◆ Pre Image / f Image

If an element $a \in A$ is associated to an element $b \in B$, then b is called 'the f -image of a ' or 'image of a under f ' or 'the value of the function f at a '. Also, a is called the pre-image of b under the function f . We write it as : $b = f(a)$.

🔍 Example. 1

Let $A = \{2, 4, 6, 8\}$ and $B = \{s, t, u, v, w\}$ be two sets and let f_1, f_2, f_3 and f_4 be rules associating elements of A to elements of B as shown in the following figures.

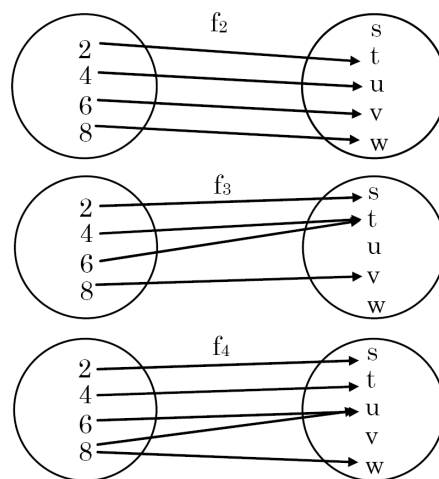
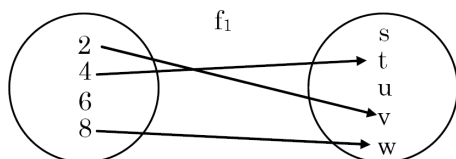

Now see that f_1 is not function from set A to set B , since there is an element $6 \in A$ which is not associated to any element of B . But f_2 and f_3 are the functions from A to B , because under f_2 and f_3 each element of A is associated to a unique element in B . But f_4 is not a function from A to B because an element $8 \in A$ is associated to two element u and w in B .

3. WAYS OF REPRESENTING FUNCTIONS

◆ Analytical Representation

$$y = \sqrt{x^2 - 1}, f(x) = \frac{\log_e x + e^x}{\sin x}$$

$$f(x) = \frac{ax^2 + bx + c}{e^{2x} \sin^{-1} x}, \dots\dots\dots$$

Representation of a function in above way is called analytical representation. i.e. when function is denoted like $y = f(x)$ or $f(x, y) = 0$, then it is called **Analytical Representation**.

◆ Graphical Representation

In 2D a set of points $M(x, y)$ provided no two or more points lie in same straight line parallel to axis of y . Then $M(x, y)$ represents a function, where x 's denotes arguments and y denotes the value of function.

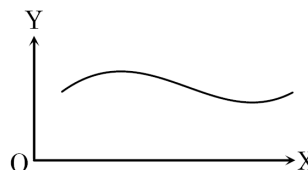

Important Points

This part contains important concepts & formulas of chapter at one place in short manner, So that student can revise all these in short time.



Points to Remember

The function whose period is 2π

1. $(\sin x)^{2n+1}, (\cos x)^{2n+1}, (\sec x)^{2n+1}, (\operatorname{cosec} x)^{2n+1}$

The function whose period is π

2. $(\sin x)^{2n}, (\cos x)^{2n}, (\sec x)^{2n}, (\operatorname{cosec} x)^{2n}$

3. $(\tan x)^n, (\cot x)^n$

4. $|\sin x|, |\cos x|, |\tan x|, |\cot x|, |\sec x|, |\operatorname{cosec} x|$

5. If $f(x)$ has the period T , then $f(\pm ax + b)$ will have the period $\frac{T}{|a|}$

6. If $f_1(x)$ has the period T_1

$f_2(x)$ has the period T_2

Then period of $af_1(x) + bf_2(x)$ will be

Solved Examples (JEE Main/Advanced)

To understand the application of concepts, there is a solved example section. It contains large variety of all types of solved examples with explanation to ensure understanding the application of concepts.

SOLVED EXAMPLES

Ex.1 Find the domain and range of the function

$$f(x) = \sqrt{2-x} + \sqrt{1+x}$$

Sol. Domain of $f(x) = \{x \mid 2-x \geq 0 \text{ and } 1+x \geq 0\}$

$$\therefore \text{domain of } f(x) = [-1, 2]$$

$$\begin{aligned} \text{Again, } \{f(x)\}^2 &= (\sqrt{2-x} + \sqrt{1+x})^2 \\ &= 3 + 2\sqrt{(2-x)(1+x)} \\ &= 3 + 2\sqrt{2+x-x^2} \\ &= 3 + 2\sqrt{\frac{9}{4} - \left(x - \frac{1}{2}\right)^2} \end{aligned}$$

\therefore the greatest value of $\{f(x)\}^2$

$$= 3 + 2 \cdot \sqrt{\frac{9}{4}} = 6, \text{ when } x = \frac{1}{2}$$

the least value of $\{f(x)\}^2 = 3 + 0 = 3$,

$$\text{when } x - \frac{1}{2} = \frac{3}{2}, \text{ i.e. } x = 2$$

\therefore the greatest value of $f(x) = \sqrt{6}$

and the least value of $f(x) = \sqrt{3}$

\therefore range of $f(x) = [\sqrt{3}, \sqrt{6}]$

Ex.2 Find the range of the following function

$$f(x) = \frac{3}{2-x^2}$$

$$= \log_2 \left(\sin \left(\pi - \frac{\pi}{4} \right) + 3 \right) = y \text{ (let)}$$

$$\Rightarrow 2^y = \sin \left(\pi - \frac{\pi}{4} \right) + 3$$

$$\Rightarrow 2^y - 3 = \sin \left(\pi - \frac{\pi}{4} \right)$$

$$\text{But } -1 \leq \sin \left(\pi - \frac{\pi}{4} \right) \leq 1$$

$$\therefore -1 \leq 2^y - 3 \leq 1$$

$$\Rightarrow 2 \leq 2^y \leq 4$$

$$\Rightarrow 2^1 \leq 2^y \leq 2^2$$

$$\text{Hence } y \in [1, 2].$$

Hence Range of $f(x)$ is $[1, 2]$.

Ex.4 Find the period of the following function

$$f(x) = e^{x-[x]} + |\cos \pi x| + |\cos 2\pi x| + \dots + |\cos n\pi x|,$$

$[\]$ is greatest integer function.

Sol. $f(x) = e^{x-[x]} + |\cos \pi x| + |\cos 2\pi x| + \dots + |\cos n\pi x|$

$$\text{Period of } x - [x] = 1$$

$$\text{Period of } |\cos \pi x| = 1$$

$$\text{Period of } |\cos 2\pi x| = 1/2$$

$$\dots \dots \dots$$

$$\dots \dots \dots$$

$$\text{Period of } |\cos n\pi x| = 1/n$$

So period of $f(x)$ will be

Practice Exercises

Exercise Level - 1 : It contains objective questions with single correct choice to ensure sufficient practice to accurately apply formulae and concepts.

Exercise Level - 2 : It contains single objective type questions with moderate difficulty level to enhance the conceptual and application level of the student.

Exercise Level - 3 : It contains previous years question of JEE Main from Year 2005 to 2024.

EXERCISE (Level-3) Old Examination Questions [JEE Main]

- Q.1** Let $f : (-1, 1) \rightarrow \mathbb{B}$, be a function defined by $f(x) = \tan^{-1} \frac{2x}{1-x^2}$, then f is both one-one and onto when \mathbb{B} is the interval [AIEEE-2005]
- (A) $\left(0, \frac{\pi}{2}\right)$ (B) $\left[0, \frac{\pi}{2}\right)$
 (C) $\left[-\frac{\pi}{2}, \frac{\pi}{2}\right)$ (D) $\left[-\frac{\pi}{2}, \frac{\pi}{2}\right]$
- Q.2** A real valued function $f(x)$ satisfies the functional equation $f(x-y) = f(x)f(y) - f(a-x)f(a+y)$ where a is a given constant and $f(0) = 1$, then $f(2a-x)$ is equal to - [AIEEE-2005]
- (A) $-f(x)$ (B) $f(x)$
 (C) $f(a) + f(a-x)$ (D) $f(-x)$
- Q.3** The largest interval lying in $\left(-\frac{\pi}{2}, \frac{\pi}{2}\right)$ for which the function $f(x) = 4^{-x^2} + \cos^{-1}\left(\frac{x}{2} - 1\right) + \log(\cos x)$ defined, is - [AIEEE 2007]
- (A) $[0, \pi]$ (B) $\left(-\frac{\pi}{2}, \frac{\pi}{2}\right)$
 (C) $\left[-\frac{\pi}{4}, \frac{\pi}{2}\right)$ (D) $\left[0, \frac{\pi}{2}\right)$
- Q.4** Let $f : \mathbb{N} \rightarrow \mathbb{Y}$ be a function defined as $f(x) = 4x + 3$ where $\mathbb{Y} = \{y \in \mathbb{N} : y = 4x + 3 \text{ for some } x \in \mathbb{N}\}$. Inverse of f is - [AIEEE 2008]
- (A) $g(y) = 4 + \frac{y+3}{4}$ (B) $g(y) = \frac{y+3}{4}$
 (C) $g(y) = \frac{y-3}{4}$ (D) $g(y) = \frac{3y+4}{3}$
- Q.5** For real x , let $f(x) = x^3 + 5x + 1$, then - [AIEEE 2009]
- (A) f is one - one but not onto on \mathbb{R}
 (B) f is onto on \mathbb{R} but not one - one
 (C) f is one - one and onto on \mathbb{R}
 (D) f is neither one - one nor onto on \mathbb{R}
- Q.6** Let $f(x) = (x+1)^2 - 1, x \geq -1$
Statement - 1 : The set $\{x : f(x) = f^{-1}(x)\} = \{0, -1\}$.
Statement - 2 : f is a bijection. [AIEEE 2009]
- (A) Statement -1 is true, Statement-2 is true; Statement-2 is a correct explanation for Statement -1
 (B) Statement-1 is true, Statement-2 is true; Statement-2 is **not** a correct explanation for Statement -1.
 (C) Statement -1 is true, Statement-2 is false.
 (D) Statement -1 is false, Statement-2 is true
- Q.7** The domain of the function $f(x) = \frac{1}{\sqrt{|x|-x}}$ is : [AIEEE 2011]
- (A) $(-\infty, \infty)$ (B) $(0, \infty)$
 (C) $(-\infty, 0)$ (D) $(-\infty, \infty) - \{0\}$
- Q.8** Let A and B be nonempty set in \mathbb{R} and $f : A \rightarrow B$ be a bijective function.
Statement-1: f is an onto function
Statement-2 : There exists a function $g : B \rightarrow A$ such that $f \circ g = I_B$. [AIEEE Online- 2012]
- (A) Statement-1 is true, Statement-2 is true and Statement-2 is the correct explanation of Statement-1
 (B) Statement-1 is true, Statement-2 is true and Statement-2 is not the correct explanation of statement-1
 (C) Statement-1 is true, Statement-2 is false
 (D) Statement-1 is false, Statement-2 is true
- Q.9** The range of the function $f(x) = \frac{x}{1+|x|}, x \in \mathbb{R}$ is : [AIEEE Online- 2012]
- (A) $[-1, 1]$ (B) \mathbb{R} (C) $\mathbb{R} - \{0\}$ (D) $(-1, 1)$
- Q.10** If $P(S)$ denotes the set of all subsets of a given set S , then the number of one to one functions from the set $S = \{1, 2, 3\}$ to the set $P(S)$ is : [AIEEE Online- 2012]
- (A) 24 (B) 8 (C) 336 (D) 320
- Q.11** Let $A = \{1, 2, 3, 4\}$ and $R : A \rightarrow A$ be the relation defined by $R = \{(1, 1), (2, 3), (3, 4), (4, 2)\}$. The correct statements is : [JEE Main Online -2013]
- (A) R does not have an inverse
 (B) R is not a one to one function
 (C) R is an onto function
 (D) R is not a function
- Q.12** If $a \in \mathbb{R}$ and the equation $-3(x-[x])^2 + 2(x-[x]) + a^2 = 0$ (where $[x]$ denotes the greatest integer $\leq x$) has no integral solution, then all possible values of a lie in the interval : [JEE Main -2014]
- (A) $(-\infty, -2) \cup (2, \infty)$ (B) $(-1, 0) \cup (0, 1)$
 (C) $(1, 2)$ (D) $(-2, -1)$

Exercise Level - 4 : It contains all variety of questions as per level of JEE Advanced such as MCQ, Column match, Passage based & Numerical type etc.

EXERCISE (Level-4)

Part-A : Multiple correct answer type questions

- Q.1** If $f(x) = \sqrt{x^2 - |x|}$, $g(x) = \frac{1}{\sqrt{9 - x^2}}$ then D_{f+g} contains
 (A) $(-3, -1)$ (B) $[1, 3)$
 (C) $[-3, 3]$ (D) $\{0\} \cup [1, 3)$
- Q.2** If $f(x) = \frac{3x-1}{3x^3+2x^2-x}$ and $S = \{x \mid f(x) > 0\}$ then S contains
 (A) $(-\infty, -2)$ (B) $(\frac{1}{3}, 5)$
 (C) $(-\infty, -1)$ (D) $(0, \infty) - \{\frac{1}{3}\}$
- Q.3** If D is the domain of the function $f(x) = \sqrt{1-2x} + 3 \sin^{-1}\left(\frac{3x-1}{2}\right)$ then D contains-
 (A) $\left[-\frac{1}{3}, \frac{1}{2}\right]$ (B) $\left[-\frac{1}{3}, 0\right]$
 (C) $\left[-\frac{1}{3}, 1\right]$ (D) $\left[\frac{1}{2}, 1\right]$
- Q.4** Let $A = R - \{2\}$ and $B = R - \{1\}$.
 Let $f: A \rightarrow B$ be defined by $f(x) = \frac{x-3}{x-2}$ then-
 (A) f is one-one (B) f is onto
 (C) f is bijective (D) None of these
- Q.5** If $F(x) = \frac{\sin \pi[x]}{\{x\}}$, then $F(x)$ is:
 (A) Periodic with fundamental period 1
 (B) Even
 (C) Range is singleton
 (D) Identical to $\operatorname{sgn}\left(\operatorname{sgn}\frac{\{x\}}{\sqrt{\{x\}}}\right) - 1$, where $\{x\}$ denotes fractional part function and $[.]$ denotes greatest integer function and $\operatorname{sgn}(x)$ is a signum function.
- Q.6** Let $f: [-1, 1] \rightarrow [0, 2]$ be a linear function which is onto then $f(x)$ is/are
 (A) $1-x$ (B) $1+x$ (C) $x-1$ (D) $x+2$
- Q.7** In the following functions defined from $[-1, 1]$ to $[-1, 1]$ the functions which are not bijective are:
 (A) $\sin(\sin^{-1}x)$ (B) $\frac{2}{\pi} \sin^{-1}(\sin x)$
 (C) $(\operatorname{sgn} x) \ln e^x$ (D) $x^3 \operatorname{sgn} x$
- Q.8** Which of the following function is periodic?
 (A) $\operatorname{sgn}(e^{-x})$
 (B) $\sin x + |\sin x|$
 (C) $\min(\sin x, |x|)$
 (D) $\left[x + \frac{1}{2}\right] + \left[x - \frac{1}{2}\right] + 2[-x]$
 Where $[x]$ denotes greatest integer function.
- Q.9** If $f(x) = \begin{cases} 2x+3 & x \leq 1 \\ a^2x+1 & x > 1 \end{cases}$ then values of 'a' for which $f(x)$ is injective is
 (A) -3 (B) 3 (C) 0 (D) 1
- Q.10** Consider the function $y = f(x)$ satisfying the condition $f\left(x + \frac{1}{x}\right) = x^2 + \frac{1}{x^2}$ ($x \neq 0$), then
 (A) domain of $f(x)$ is R
 (B) domain of $f(x)$ is $R - (-2, 2)$
 (C) range of $f(x)$ is $[-2, \infty)$
 (D) range of $f(x)$ is $[2, \infty)$
- Q.11** Consider the real-valued function satisfying $2f(\sin x) + f(\cos x) = x$. Then
 (A) domain of $f(x)$ is R
 (B) domain of $f(x)$ is $[-1, 1]$
 (C) range of $f(x)$ is $\left[-\frac{2\pi}{3}, \frac{\pi}{3}\right]$
 (D) range of $f(x)$ is R
- Q.12** Let $f(x) = x^2 - 2ax + a(a+1)$, $f: [a, \infty) \rightarrow [a, \infty)$. If one of the solutions of the equation $f(x) = f^{-1}(x)$ is 5049, then the other may be
 (A) 5051 (B) 5048 (C) 5052 (D) 5050
- Q.13** If $f: R^+ \rightarrow R^+$ is a polynomial function satisfying the functional equation $f(f(x)) = 6x - f(x)$, then $f(17)$ is equal to -
 (A) 17 (B) -51 (C) 34 (D) -34
- Q.14** $f: R \rightarrow [-1, \infty)$ and $f(x) = \ln(|\sin 2x| + |\cos 2x|)$ (where $[.]$ is the greatest integer function)
 (A) $f(x)$ has range Z
 (B) $f(x)$ is periodic with fundamental period $\pi/4$
 (C) $f(x)$ is invertible in $\left[0, \frac{\pi}{4}\right]$
 (D) $f(x)$ is into function
- Q.15** Let $f(x) = \operatorname{sgn}(\cot^{-1}x) + \tan\left(\frac{\pi}{2}[x]\right)$, where $[x]$ is the greatest integer function less than or equal x . Then which of the following alternatives is/are true?
 (A) $f(x)$ is many one but not even function
 (B) $f(x)$ is periodic function
 (C) $f(x)$ is bounded function
 (D) Graph of $f(x)$ remains above the x -axis

Exercise Level - 5 : It contains previous years question of JEE Advanced from Year 2005 to 2024.

EXERCISE (Level-5)

Old Examination Questions [JEE Advanced]

- Q.1** $f(x) = \begin{cases} x, & x \in Q \\ 0, & x \notin Q \end{cases}; g(x) = \begin{cases} 0 & x \in Q \\ x & x \notin Q \end{cases}$
 then $(f - g)$ is [IIT Scr. 2005]
 (A) one-one, onto
 (B) neither one-one, nor onto
 (C) one-one but not onto
 (D) onto but not one-one

- Q.2** If X and Y are two non-empty sets where $f: X \rightarrow Y$ is function is defined such that $f(C) = \{f(x): x \in C\}$ for $C \subseteq X$ and $f^{-1}(D) = \{x: f(x) \in D\}$ for $D \subseteq Y$ for any $A \subseteq X$ and $B \subseteq Y$ then- [IIT 2005]
 (A) $f^{-1}(f(A)) = A$
 (B) $f^{-1}(f(A)) = A$ only if $f(X) = Y$
 (C) $f(f^{-1}(B)) = B$ only if $B \subseteq f(X)$
 (D) $f(f^{-1}(B)) = B$

- Q.3** Find the range of values of t for which $2 \sin t = \frac{1 - 2x + 5x^2}{3x^2 - 2x - 1}; t \in \left[-\frac{\pi}{2}, \frac{\pi}{2}\right]$
[IIT 2005]

- Q.4** Let $f(x) = \frac{x^2 - 6x + 5}{x^2 - 5x + 6}$ [IIT 2007].

- | Column-I | Column-II |
|---|--------------------|
| (A) If $-1 < x < 1$, then $f(x)$ satisfies | (P) $0 < f(x) < 1$ |
| (B) If $1 < x < 2$, then $f(x)$ satisfies | (Q) $f(x) < 0$ |
| (C) If $3 < x < 5$, then $f(x)$ satisfies | (R) $f(x) > 0$ |
| (D) If $x > 5$, then $f(x)$ satisfies | (S) $f(x) < 1$ |

- Q.5** Let $f(x) = x^2$ and $g(x) = \sin x$ for all $x \in R$. Then the set of all x satisfying $(f \circ g \circ g \circ f)(x) = (g \circ g \circ f \circ f)(x)$, where $(f \circ g)(x) = f(g(x))$, is [IIT 2011]

- (A) $\pm\sqrt{n\pi}, n \in \{0, 1, 2, \dots\}$
 (B) $\pm\sqrt{n\pi}, n \in \{1, 2, \dots\}$
 (C) $\frac{\pi}{2} + 2n\pi, n \in \{\dots, -2, -1, 0, 1, 2, \dots\}$
 (D) $2n\pi, n \in \{\dots, -2, -1, 0, 1, 2, \dots\}$

- Q.6** The function $f: [0, 3] \rightarrow [1, 29]$, defined by $f(x) = 2x^3 - 15x^2 + 36x + 1$, is [IIT 2012]
 (A) one-one and onto.
 (B) onto but not one-one.
 (C) one-one but not onto.
 (D) neither one-one nor onto.

- Q.7** Let $f: (-1, 1) \rightarrow \mathbb{R}$ be such that $f(\cos 4\theta) = \frac{2}{2 - \sec^2 \theta}$ for $\theta \in \left(0, \frac{\pi}{4}\right) \cup \left(\frac{\pi}{4}, \frac{\pi}{2}\right)$.
 Then the value(s) of $f\left(\frac{1}{3}\right)$ is (are)

MCQ [IIT 2012]

- (A) $1 - \sqrt{\frac{3}{2}}$ (B) $1 + \sqrt{\frac{3}{2}}$
 (C) $1 - \sqrt{\frac{2}{3}}$ (D) $1 + \sqrt{\frac{2}{3}}$

- Q.8** Let $f: \left(-\frac{\pi}{2}, \frac{\pi}{2}\right) \rightarrow \mathbb{R}$ be given by

- $f(x) = (\log(\sec x + \tan x))^3$. Then [MCQ [IIT-Advance 2014]]
 (A) $f(x)$ is an odd function
 (B) $f(x)$ is a one-one function
 (C) $f(x)$ is an onto function
 (D) $f(x)$ is an even function

- Q.9** Let $f(x) = \sin\left(\frac{\pi}{6} \sin\left(\frac{\pi}{2} \sin x\right)\right)$ for all $x \in R$

and $g(x) = \frac{\pi}{2} \sin x$ for all $x \in R$. Let $(f \circ g)(x)$

denote $f(g(x))$ and $(g \circ f)(x)$ denote $g(f(x))$. Then which of the following is (are) true?

MCQ [IIT-Advance 2015]

- (A) Range of f is $\left[-\frac{1}{2}, \frac{1}{2}\right]$
 (B) Range of $f \circ g$ is $\left[-\frac{1}{2}, \frac{1}{2}\right]$

(C) $\lim_{x \rightarrow 0} \frac{f(x)}{g(x)} = \frac{\pi}{6}$

- (D) There is an $x \in R$ such that $(g \circ f)(x) = 1$

- Q.10** Let X be a set with exactly 5 elements and Y be a set with exactly 7 elements. If α is the number of one-one functions from X to Y and β is the number of onto functions from Y to X , then the value of $\frac{1}{5!}(\beta - \alpha)$ is _____. [JEE - Advance 2018]

Exercise Level - 6 : Advanced level a bit complex questions for students for solid rock preparation for Top Rankers.

Answer key

Answer key is provided at the end of the exercise sheets.

ANSWER KEY						
EXERCISE (Level-1)						
1. (A)	2. (D)	3. (C)	4. (D)	5. (A)	6. (C)	7. (B)
8. (C)	9. (C)	10. (B)	11. (C)	12. (A)	13. (D)	14. (C)
15. (A)	16. (D)	17. (B)	18. (D)	19. (B)	20. (A)	21. (B)
22. (C)	23. (B)	24. (C)	25. (A)	26. (A)	27. (A)	28. (B)
29. (B)	30. (B)	31. (A)	32. (D)	33. (B)	34. (D)	35. (A)
36. (A)	37. (A)	38. (D)	39. (C)	40. (A)	41. (A)	

Revision Plan

We emphasize that every student should prepare his/her own revision plan. For this purpose there is Revision Plan Section in each chapter which student should prepare while going through the study material. This will be useful at the time of final revision before final exam for quick & effective revision.

Revision Plan

Prepare Your Revision plan today!

After attempting Exercise Sheet, please fill below table as per the instruction given.

- Write Question Number (QN) which you are unable to solve at your own in **column A**.
- After discussing the Questions written in **column A** with faculty, strike off them in the manner so that you can see at the time question number during Revision, to solve such questions again.
- Write down the Question Number you feel are important or good in the **column B**.

EXERCISE	COLUMN A	COLUMN B
	Questions unable to solve in first attempt	Good or Important questions
Topic wise practice questions		
Level-1		
Level-2		
Level-3		
Level-4		
Level-5		
Level-6		

Revision Strategy:

Whenever you wish to revision this chapter, follow the following steps-

Step-1: Review your theory notes.

Step-2: Solve Questions of column A

Online Solutions

Self explanatory and detailed solution of all exercises above are available on Career Point website www.careerpoint.ac.in

FUNCTION EXERCISE (Level-1)

Answer Key & Solution

Question Number	Solution
1	Click Here
2	Click Here
3	Click Here
4	Click Here
5	Click Here
6	Click Here
7	Click Here
8	Click Here
9	Click Here
10	Click Here
11	Click Here
12	Click Here
13	Click Here
14	Click Here
15	Click Here
16	Click Here
17	Click Here
18	Click Here
19	Click Here
20	Click Here
21	Click Here

Question Number	Solution
22	Click Here
23	Click Here
24	Click Here
25	Click Here
26	Click Here
27	Click Here
28	Click Here
29	Click Here
30	Click Here
31	Click Here
32	Click Here
33	Click Here
34	Click Here
35	Click Here
36	Click Here
37	Click Here
38	Click Here
39	Click Here
40	Click Here
41	Click Here

FUNCTION

JEE ADVANCED SYLLABUS

1. *Domain and range of functions*
2. *Into, Onto and one-to-one function*
3. *Sum, Difference, Product and quotient of two functions*
4. *Composite Function*
5. *Absolute value*
6. *Greatest integer, Polynomial, Rational, Trigonometric, Exponential and logarithmic functions*
7. *Even and odd functions*
8. *Inverse of a function*

Revision Plan

Prepare Your Revision plan today!

After attempting Exercise Sheet, please fill below table as per the instruction given.

- A. Write Question Number (QN) which you are unable to solve at your own in **column A**.
- B. After discussing the Questions written in **column A** with faculty, strike off them in the manner so that you can see at the time question number during Revision, to solve such questions again.
- C. Write down the Question Number you feel are important or good in the **column B**.

EXERCISE	COLUMN A	COLUMN B
	Questions unable to solve in first attempt	Good or Important questions
Level-1		
Level-2		
Level-3		
Level-4		
Level-5		
Level-6		

Revision Strategy:

Whenever you wish to revision this chapter, follow the following steps-

Step-1: Review your theory notes.

Step-2: Solve Questions of Column A

Step-3: Solve Questions of Column B

Step-4: Solve questions from other Question Bank, Problem book etc.

Function

1. PRELIMINARIES

◆ Tricotomy Law

The real numbers are ordered in magnitude means. If x and y be two real numbers then there will be one and only one of the following relation will hold.

$$x < y, x = y, x > y$$

◆ Interval

The set of numbers between any two real numbers is called interval. The following are the types of interval.

(a) Closed Interval

$$[a, b] = \{x, a \leq x \leq b\}$$

(b) Open Interval

$$(a, b) \text{ or }]a, b[= \{x, a < x < b\}$$

(c) Semi open or semi closed interval

$$[a, b[\text{ or } [a, b) = \{x; a \leq x < b\}$$

$$]a, b] \text{ or } (a, b] = \{x; a < x \leq b\}$$

2. DEFINITION OF FUNCTION

Let A and B be two non-empty sets. Then a function ' f ' from set A to set B is a rule which associates elements of set A to elements of set B such that

- All elements of set A are associated to element in set B .
- An element of set A is associated to a unique element in set B .

Terms such as "map" (or "mapping"), "correspondence" are used as synonyms for "function". If f is a function from a set A to set B , then we write $f : A \rightarrow B$ or $A \xrightarrow{f} B$, which is read as f is a function from A to B or f maps A to B .

◆ Pre Image / f Image

If an element $a \in A$ is associated to an element $b \in B$, then b is called 'the f -image of a ' or 'image of a under f ' or 'the value of the function f at a '. Also, a is called the pre-image of b under the function f . We write it as : $b = f(a)$.

✎ Example. 1

Let $A = \{2, 4, 6, 8\}$ and $B = \{s, t, u, v, w\}$ be two sets and let f_1, f_2, f_3 and f_4 be rules associating elements of A to elements of B as shown in the following figures.

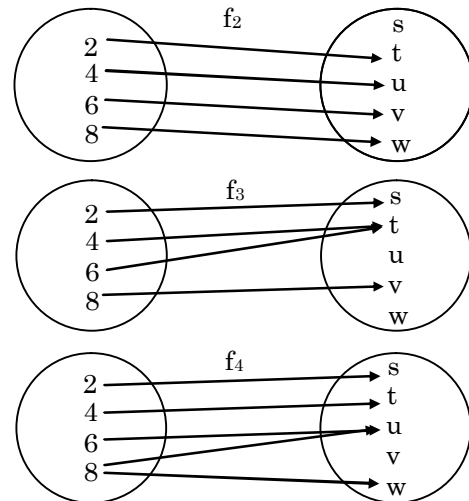
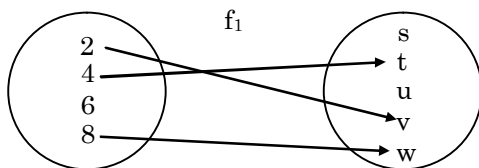

Now see that f_1 is not function from set A to set B , since there is an element $6 \in A$ which is not associated to any element of B . But f_2 and f_3 are the functions from A to B , because under f_2 and f_3 each element of A is associated to a unique element in B . But f_4 is not a function from A to B because an element $8 \in A$ is associated to two element u and w in B .

3. WAYS OF REPRESENTING FUNCTIONS

◆ Analytical Representation

$$y = \sqrt{x^2 - 1}, f(x) = \frac{\log_e x + e^x}{\sin x}$$

$$f(x) = \frac{ax^2 + bx + c}{e^{2x} \sin^{-1} x}, \dots\dots$$

Representation of a function in above way is called analytical representation. i.e. when function is denoted like $y = f(x)$ or $f(x, y) = 0$, then it is called **Analytical Representation**.

◆ Graphical Representation

In 2D a set of points $M(x, y)$ provided no two or more points lie in same straight line parallel to axis of y . Then $M(x, y)$ represents a function, where x 's denotes arguments and y denotes the value of function.

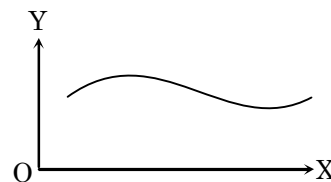

◆ Mapping

A mapping $f : X \rightarrow Y$ is said to be function if each element in the set X has its image in set Y . This may be possible that the set Y may contain same such elements which may not be the images of any element of set X .

Each element in set X can not have more than one image. But this is possible that more than one element of X can have the same image.

- **Domain, Co-domain :** Set X is called domain of f i.e. Set of those elements from which functions is to be define and set Y is called Co-domain of f i.e. Set of those elements into which the function is to be define.
- **Range of f :** Set of images of each element of X , is called range of f .

NOTE → Range \subseteq Co domain

◆ Function as an ordered pair

Let A and B be two non - empty sets. A relation from A to B , i.e., a sub -set of $A \times B$, is called a function (or a mapping or a map) from A to B if

- For each $a \in A$ there exists $b \in B$ such that $(a, b) \in f$,
- $(a, b) \in f$ and $(a, c) \in f \Rightarrow b = c$.

Thus, a non - empty subset f of $A \times B$ is a function from A to B if each element of A appear in some ordered pair in f and no two ordered pairs in f have the same first element.

If $(a, b) \in f$, then b is called the image of a under f .

✎ Example. 2

Let $A = \{a, b, c\}$, $B = \{2, 3, 4\}$ and f_1, f_2 and f_3, \dots be subsets of $A \times B$ then

$$f_1 = \{(a, 2), (b, 3), (c, 4)\}$$

$$f_2 = \{(a, 2), (a, 3), (b, 3), (c, 4)\},$$

$$f_3 = \{(a, 3), (a, 4)\}$$

$$f_4 = \{(a, 2), (c, 3), (b, 4)\}$$

Then f_1 and f_4 is a function from A to B but f_2 and f_3 are not functions from A to B .

Reason :

The element in f_2 has two images as 2 and 3 also in f_3 also is the same that is why f_2 and f_3 are not the functions.

4. DOMAIN

Set of those values of x for which $f(x)$ is defined called domain of $y = f(x)$. For example $y = \log_e x$ is defined for $x > 0$ therefore domain of $y = \log_e x$ is \mathbb{R}^+ . $y = \sin x$ is defined $\forall x$ therefore domain of $\sin x$ is \mathbb{R} .

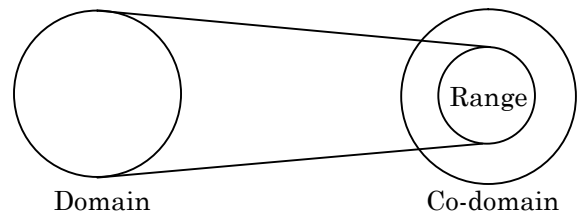

REMEMBER

$$\begin{aligned} \text{Dom } (f + g + h \dots) &= \text{Dom } f \cap \text{Dom } g \cap \text{Dom } h \dots \\ \text{Dom } (f - g) &= \text{Dom } f \cap \text{Dom } g \\ \text{Dom } (f \times g \times h \dots) &= \text{Dom } f \cap \text{Dom } g \cap \text{Dom } h \dots \\ \text{Dom } (f/g) &= \text{Dom } f \cap \text{Dom } g - \{x : g(x) = 0\} \end{aligned}$$

Example Based on

Domain of Definition

✎ Example. 3

Find the domain of $f(x) = \log_{10} \sin x$

Solution.

For existence of $f(x)$, $\sin x > 0$ and from the graph of $y = \sin x$ it is clear that $\sin x$ is +ve when $2n\pi < x < (2n + 1)\pi$

Hence $\text{Dom } f(x) = (2n\pi, (2n + 1)\pi)$, where $n \in \mathbb{I}$.

✎ Example. 4

Find the domain of definition of $f(x) = \frac{1}{\sqrt{x - |x|}}$

Solution.

$$x - |x| > 0$$

$$\Rightarrow x > |x|$$

and already we know $|x| \geq x$.
this contradiction

$$\Rightarrow \text{Dom } f(x) = \phi.$$

✎ Example. 5

Find the domain of $f(x) = \sin x + \cos x + e^x \tan x$.

Solution.

$$\text{Dom } \sin x = \mathbb{R}$$

$$\text{Dom } \cos x = \mathbb{R}$$

$$\text{Dom } \tan x = \mathbb{R} - \left\{ \frac{2n+1}{2} \pi \right\}$$

$$\text{Dom } e^x = \mathbb{R}$$

$$\therefore \text{Dom } f = \text{Dom } \sin x \cap \text{Dom } \cos x \cap \text{Dom } e^x \tan x$$

$$= \mathbb{R} \cap \mathbb{R} \cap \mathbb{R} - \left\{ \frac{2n+1}{2} \pi \right\} = \mathbb{R} - \left\{ \frac{2n+1}{2} \pi \right\}$$

5. RANGE

Set of values of $f(x)$ which it attains at points in its domain is called as range of $f(x)$.

Example Based on

Range of Function

✎ Example. 6

Find the range of function $f(x) = \sqrt{\sin x}$

Solution.

$$-1 \leq \sin x \leq 1 \Rightarrow 0 \leq \sqrt{\sin x} \leq 1$$

\therefore Range $f = [0, 1]$

Example. 7

Find the range of $f(x) = 3^{\sin^{-1} x}$

Solution.

$$-\frac{\pi}{2} \leq \sin^{-1} x \leq \frac{\pi}{2}$$

$$3^{-\pi/2} \leq f(x) \leq 3^{\pi/2}$$

\therefore Range $f = [3^{-\pi/2}, 3^{\pi/2}]$

6. KINDS OF FUNCTION

The following are the kinds of functions :

◆ **One-One Function (Injective)**

If each element in the domain of a function has a distinct image in the co-domain, the function is said to be One-One. One-One function is also known as Injective Function.

e.g. $f : \mathbb{R} \rightarrow \mathbb{R}^+$ given by $y = e^x$ $y = 2^{-x}$,
 $g : \mathbb{R} \rightarrow \mathbb{R}$ given & $g(x) = 3x - 7$ are One-One functions.

or, $f : A \rightarrow B$ is one-one
 $\Leftrightarrow a \neq b \Rightarrow f(a) \neq f(b)$ for all $a, b \in A$
 $\Leftrightarrow f(a) = f(b) \Rightarrow a = b$ for all $a, b \in A$

e.g. $y = \sin^{-1} x, y = \cos^{-1} x,$
 $y = e^x, y = \log_e x, \dots\dots\dots$

◆ **Many-One Function**

If two or more than two elements of domain have the same image. Then $f(x)$ is called Many-One.

e.g. $f : \mathbb{R} \rightarrow \mathbb{R}^+ ; f(x) = x^2 + 4$
 $g : \mathbb{R} \rightarrow \mathbb{R}^+ ; g(x) = x^8 + x^4 + x^2 + 4$
 Many one
 eg $f(x) = x^2$

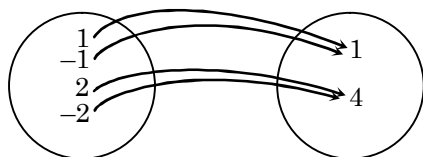

• **Horizontal line Test :**
 If the graph of $y = f(x)$ is given and the line parallel to x - axis cuts the curve at more than one point then function is many-one.

or, $f : A \rightarrow B$ is a many - one function if there exist $x, y \in A$ such that $x \neq y$ but $f(x) = f(y)$.

e.g $y = \sin x, y = \cos x, y = \tan x, y = x^2,$
 $y = x^4, \dots\dots\dots$

◆ **Onto Function (Surjective)**

Let, $f : X \rightarrow Y$ be a function. If each element in the co-domain Y has at least one pre-image in the domain X . i.e.

Range $f =$ Co domain

Then f is called **Onto**.

Onto function are also called surjective and if function be both One-One and Onto then function is called **Bijjective**.

or, $f : A \rightarrow B$ is a surjection iff for each $b \in B,$
 $\exists a \in A$ such that $f(a) = b$.

e.g. Let $f : \mathbb{R}^+ \rightarrow \mathbb{R}$ is defined by $y = \log_2 x,$ then $f(x)$ is Onto function.

But when $f : \mathbb{R} \rightarrow \mathbb{R}$ is defined by $f(x) = \sin x,$ then $f(x)$ is not Onto function.

◆ **Into Function**

If there exist one or more than one element in the Co-domain Y which is not an image of any element in the domain X . Then f is Into.

In other words $f : A \rightarrow B$ is an into function if it is not an onto function.

e.g. Let $f : \mathbb{R} \rightarrow \mathbb{R}$ is defined by $y = x^2 + 1,$ then $f(x)$ is an Into function.

But when $f : \mathbb{R} \rightarrow [0, \infty)$ is defined by $y = x^2,$ then $f(x)$ is not Into function. (**Note it**)

REMEMBER

- (i) If $\frac{dy}{dx} > 0, \forall x$ in domain then f is One One.
- (ii) If $\frac{dy}{dx} < 0, \forall x$ in domain then f is One-One.
- (iii) If a continuous function $f(x)$ which has either local minima or maxima or both then $f(x)$ will be Many-One.
- (iv) Every even function is Many-one.
- (v) Every periodic function is Many-one.

7. WHEN THE FUNCTION IS CALLED 'DEFINED' OR 'NOT DEFINED'

If

- (i) $f(x)$ gives some imaginary value at some point.
- (ii) $f(x)$ gives set of imaginary values in an interval.
- (iii) $f(x)$ is indeterminate form like $\frac{0}{0}, \frac{\infty}{\infty}, \dots\dots$

Then $f(x)$ is said to be not defined or undefined.

If

- (i) $f(x)$ is real and unique at some point (say $x = a$)
- (ii) $f(x)$ is real and unique for corresponding values in an interval.

Then $f(x)$ is said to be defined.

Consider $f(x) = \frac{x^2 - a^2}{x - a},$ obviously $f(x)$ is not defined

at $x = a,$ because $f(a) = \frac{0}{0}.$

At other point is well defined because $f(x)$ is real and unique other than $x = a$ i.e. for $x \neq a.$

Again Let, $f(x) = \frac{1}{x-a}$, At $x = a$, $f(x) = \infty$. Therefore

$f(x)$ is not defined at $x = a$ and defined for $x \neq a$ because $f(x)$ is real for x .

Let $f(x) = \sqrt{x}$,

Here $f(x)$ gives imaginary values for $x < 0$.

Therefore $f(x)$ is not defined for $x < 0$ and $f(x)$ is defined for $x \geq 0$.

Let, $f(x) = \log_e x$

For $x < 0$; $f(x)$ is imaginary

For $x = 0$; $f(x) = -\infty$

For $x > 0$; $f(x)$ is real

Here $f(x)$ is not defined for $x \leq 0$ and defined for $x > 0$

Example Based on

When the Function is Called 'Defined' or 'Not Defined'

Example. 8

Let $f(x) = 3^{\cos^{-1}(\log_e \sqrt{1-e^{2x}})}$ where $f(x)$ is not defined

Solution.

$$\log_e \sqrt{1-e^{2x}} > 1, \text{ or } \log_e \sqrt{1-e^{2x}} < -1$$

$$\text{Also } 1 - e^{2x} > 0 \Rightarrow x < 0, \dots(i)$$

$$\Rightarrow \sqrt{1-e^{2x}} > e, \text{ or } \sqrt{1-e^{2x}} < e^{-1}$$

$$\Rightarrow 1 - e^{2x} > e^2, \text{ or } 1 - e^{2x} < e^{-2}$$

$$\Rightarrow -e^{2x} > e^2 - 1, \text{ or } -e^{2x} < e^{-2} - 1$$

$$\Rightarrow e^{2x} < 1 - e^2, \text{ or } e^{2x} > 1 - e^{-2}$$

$$\Rightarrow \text{but } e^{2x} > 0,$$

$$\Rightarrow x > \frac{1}{2} (\log 1 - e^{-2}) \dots(ii)$$

From (i) and (ii), $f(x)$ is defined for $x \in (1/2 \log_e (1 - e^{-2}), 0)$

8. BASIC ELEMENTARY FUNCTIONS

The basic elementary function are the following functions with analytic representation.

Power Function

$y = x^n$, n is Rational (Note)

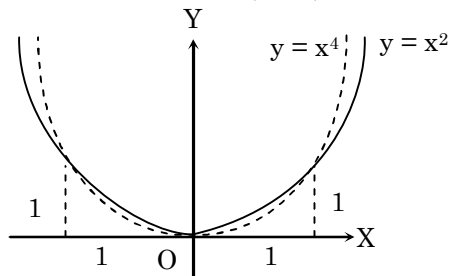

Domain : \mathbb{R}
Range : $\mathbb{R}^+ \cup \{0\}$
Nature : Many one into

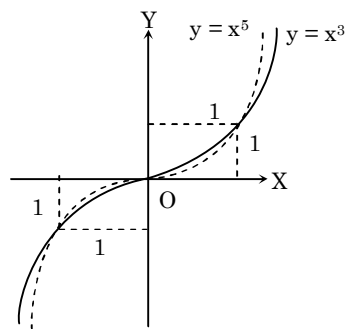

Domain : \mathbb{R}
Range : \mathbb{R}
Nature : one one onto

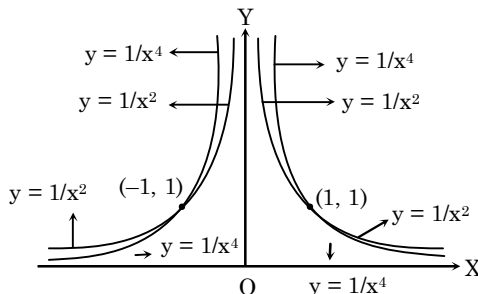

Domain : $\mathbb{R} - \{0\}$
Range : \mathbb{R}^+
Nature : Many one into

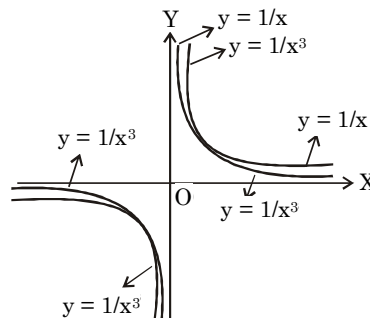

Domain : $\mathbb{R} - \{0\}$
Range : $\mathbb{R} - \{0\}$
Nature : one - one, into

General Exponential Function

$y = a^x$, $a > 0$, $a \neq 1$

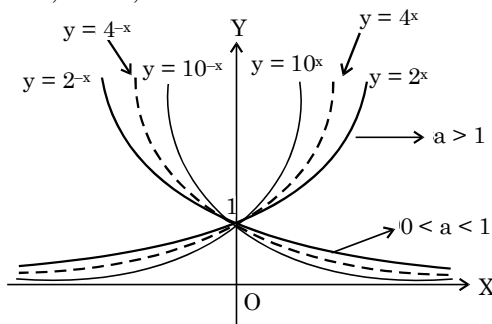

Domain : \mathbb{R}
Range : \mathbb{R}^+
Nature : one one into

NOTE For a < 0, The graph of function is not defined.

◆ **Logarithmic Function**

$y = \log_a x, \quad a > 0, \quad a \neq 1$

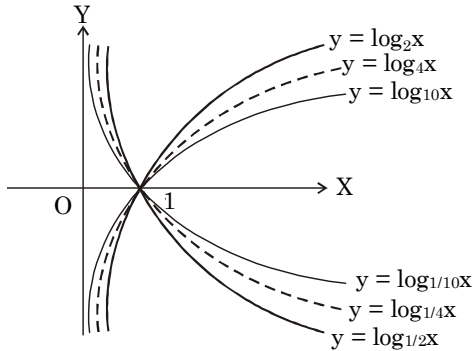

Domain : \mathbb{R}^+
 Range : \mathbb{R}
 Nature : one one into

NOTE As the base increases curve is more near to both the axis.

◆ **Trigonometric Function or Circular Function**

$y = \sin x, \quad y = \cos x, \quad y = \tan x$
 $y = \sec x, \quad y = \cot x, \quad y = \operatorname{cosec} x$
 $y = \sin x$

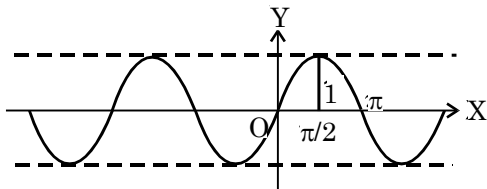

Domain : \mathbb{R}
 Range : $[-1, 1]$
 Nature : Many one into
 Principle value of x : $[-\pi/2, \pi/2]$

NOTE The graph of $y = \sin x$ is symmetric about origin i.e. symmetric in opposite quadrants.

Reason :
 $\sin x$ is odd function and every odd function is symmetric about origin.

$y = \cos x$

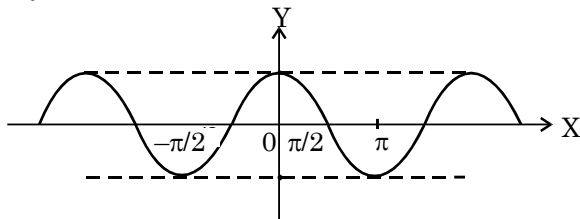

Domain : \mathbb{R}
 Range : $[-1, 1]$
 Nature : Many one into
 Principle value of x : $[0, \pi]$
 Clearly $\cos x$ is an even function therefore it is symmetrical about axis of y.
 $y = \tan x$

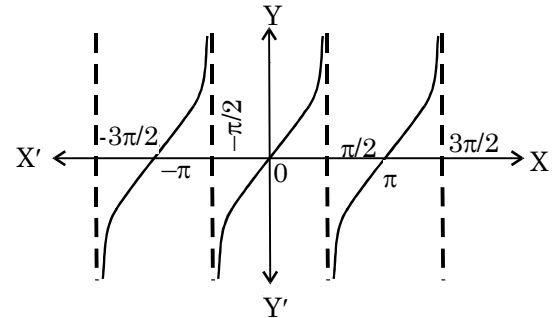

Domain : $\mathbb{R} - \left(\frac{2n+1}{2}\right)\pi$
 Range : $(-\infty, \infty)$
 Nature : Many one onto
 Principle value : $(-\pi/2, \pi/2)$
 $y = \cot x$

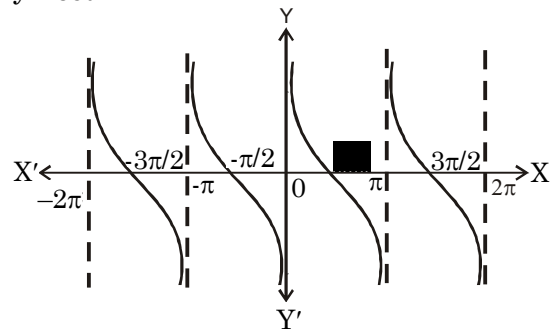

Domain : $\mathbb{R} - \pi$
 Range : $(-\infty, \infty)$
 Nature : Many one onto
 Principle value : $(0, \pi)$
 $y = \sec x$

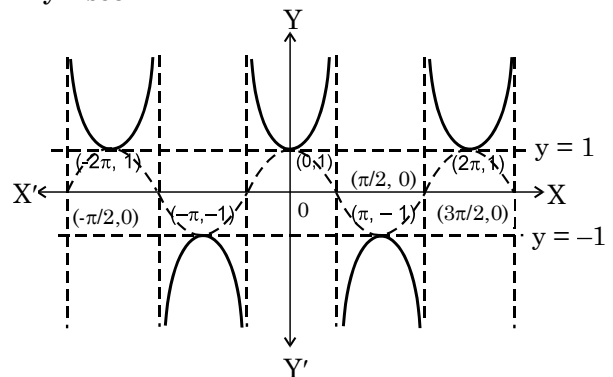

Domain : $\mathbb{R} - (2n+1)\pi/2$
 Range : $\mathbb{R} - (-1, 1) \text{ or } (-\infty, -1] \cup [1, \infty)$
 Nature : Many one into
 Principle value : same as $y = \cos x$
 $y = \operatorname{cosec} x$

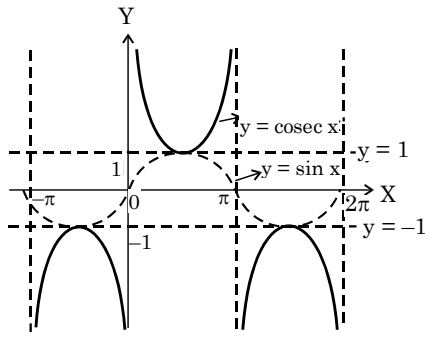

Domain : $\mathbb{R} - n\pi$
 Range : $\mathbb{R} - (-1, 1)$ or $(-\infty, -1] \cup [1, \infty)$
 Nature : Many one into
 Principle value : same as $y = \sin x$

◆ Inverse Circular Function or Inverse Trigonometric Functions

$y = \sin^{-1}x$, $y = \cos^{-1}x$, $y = \tan^{-1}x$
 $y = \cot^{-1}x$, $y = \sec^{-1}x$, $y = \operatorname{cosec}^{-1}x$
 $y = \sin^{-1}x$

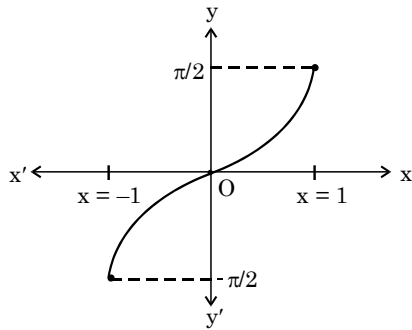

$y = \cos^{-1}x$

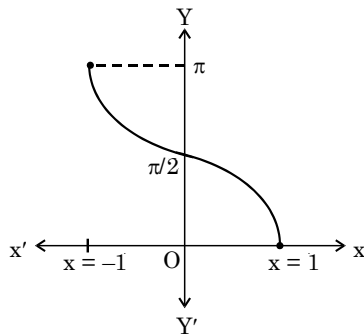

$y = \tan^{-1}x$ and $\cot^{-1}x$

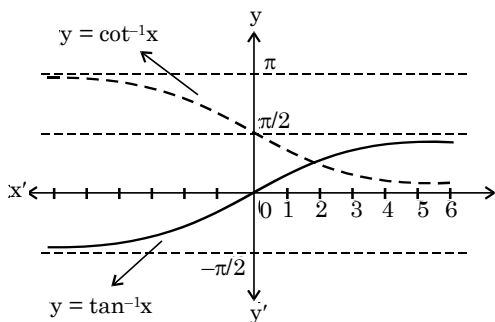

NOTE All inverse function, $f^{-1}(x)$ are drawn by taking reflection of $f(x)$ in line $y = x$.

$y = \sec^{-1}x$

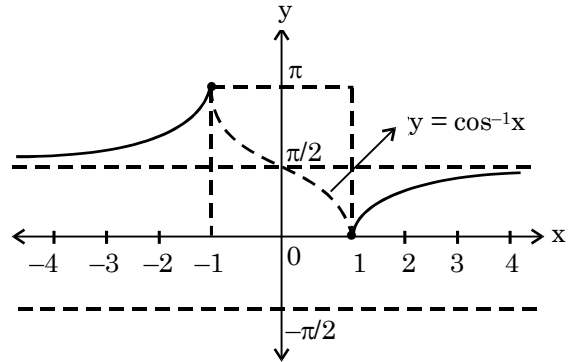

$y = \operatorname{cosec}^{-1}x$

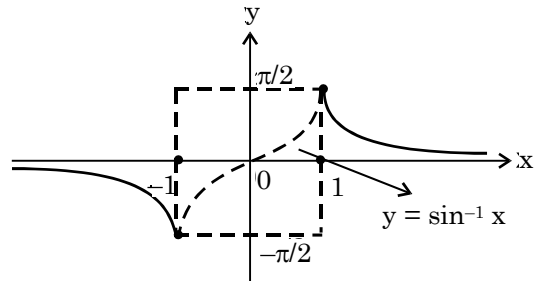

Function	Domain	Range
$\sin^{-1} x$	$[-1, 1]$	$[-\pi/2, \pi/2]$
$\cos^{-1} x$	$[-1, 1]$	$[0, \pi]$
$\tan^{-1} x$	\mathbb{R}	$(-\pi/2, +\pi/2)$
$\cot^{-1} x$	\mathbb{R}	$(0, \pi)$
$\sec^{-1} x$	$\mathbb{R} - (-1, 1)$	$[0, \pi] - \{\pi/2\}$
$\operatorname{cosec}^{-1} x$	$\mathbb{R} - (-1, 1)$	$[-\pi/2, \pi/2] - \{0\}$

9. SOME SPECIAL FUNCTION AND THEIR GRAPHS

◆ Linear Function

$f(x) = ax + b$, $a \neq 0$ and $x \in \mathbb{R}$

Where a and b are constant

Domain : \mathbb{R} , Range : \mathbb{R}

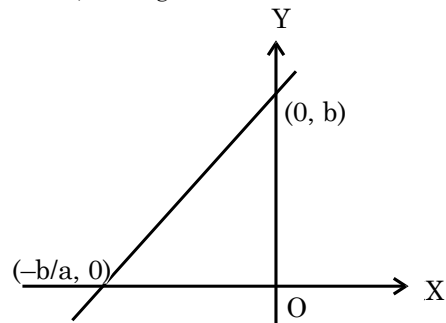

◆ Modulus Function

$$f(x) = |x| = \begin{cases} x & x \geq 0 \\ -x & x < 0 \end{cases}$$

Domain : R

Range : $[0, \infty)$

It is an even, continuous and many-one function.

Graph is symmetrical with respect to y-axis.

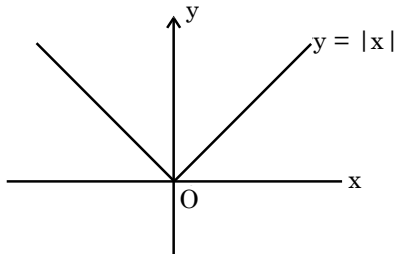

◆ Signum Function

$$f(x) = \frac{|x|}{x}, \quad x \neq 0$$

$$\text{or } f(x) = \begin{cases} -1, & x < 0 \\ 1, & x > 0 \\ 0, & x = 0 \end{cases}$$

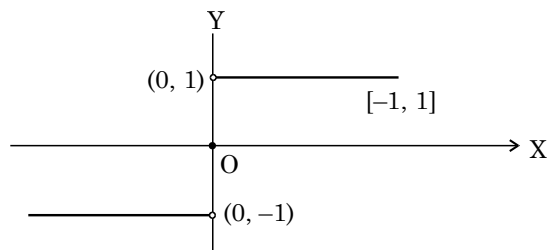

Domain : R

Range : $\{-1, 0, 1\}$

It is a many one and discontinuous function.

◆ Greatest Integer Function

A function is said to be greatest integer function if it is of the form of $f(x) = [x]$ where $[x]$ = integer equal or less than x.

The graph of this function is as follows

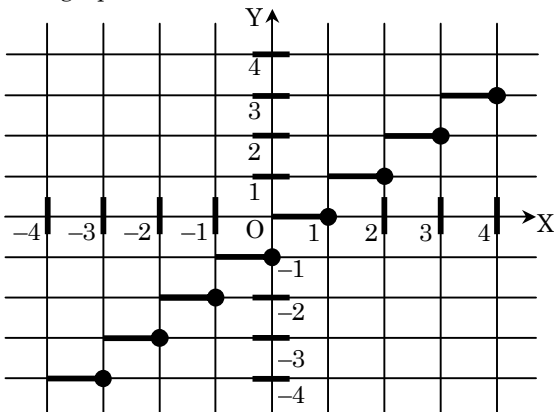

✎ Example. 9

$$[4.2] = 4, [3.6] = 3, \quad [-4.4] = -5, [-5.8] = -6$$

$$f(x) = y = [x]$$

$$0 \leq x < 1 \Rightarrow y = 0$$

$$1 \leq x < 2 \Rightarrow y = 1$$

$$2 \leq x < 3 \Rightarrow y = 2$$

\vdots

and so on

NOTE Important Identities :

(i) $x - 1 < [x] \leq x$

(ii) $[x] + 1 > x$

(iii) If $f(x) = [x + n]$, where $n \in I$ and $[.]$ denotes the greatest integer function, then $f(x) = n + [x]$

(iv) $x = [x] + \{x\}$, $[.]$ & $\{.\}$ denotes the integral and fractional part of x respectively.

(v) $x - 1 < [x] \leq x$

$$[-x] = -[x], \text{ if } x \in I$$

$$[-x] = -[x] - 1, \text{ if } x \notin I$$

$$[x] - [-x] = 2n, \text{ if } x = n, n \in I$$

$$[x] - [-x] = 2n + 1, \text{ if } x = n + \{x\}, n \in I$$

$$[x] \geq n \Rightarrow x \geq n, n \in I$$

$$[x] \leq n \Rightarrow x < n + 1, n \in I$$

$$[x] > n \Rightarrow x \geq n + 1, n \in I$$

$$[x] < n \Rightarrow x < n, n \in I$$

◆ Rectangular Hyperbola

$$f(x) = 1/x.$$

Domain : $R - \{0\}$

Range : $R - \{0\}$

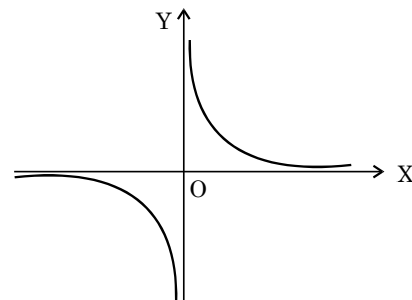

It is a continuous in its domain and one-one into function.

◆ Fractional Part of x :

$$f(x) = x - [x], \quad x \in R.$$

i.e. $f(x) = \{x\}$

$$f(x) = \begin{cases} x+1, & x \in [-1, 0) \\ x, & x \in [0, 1) \\ x-1, & x \in [1, 2) \\ 0, & x \in Z \end{cases}$$

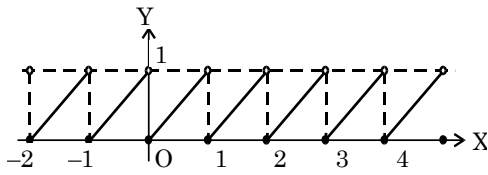

Domain : \mathbb{R}
 Range : $[0, 1)$
 Nature : Many one into
 This is a many one function with period 1. It is discontinuous at every integer.

10. TRANSFORMATION

If graph of $y = f(x)$ be known then to find the graph of

◆ $y = f(x - a)$ or $y = f(x + a)$

To find $y = f(x - a)$ (Let $a = 2$)

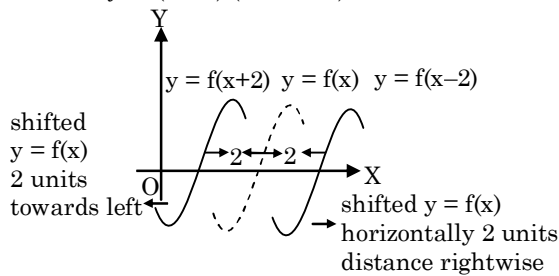

◆ $y = f(x) + a$: or $y = f(x) - a$

(Let $a = 2$)

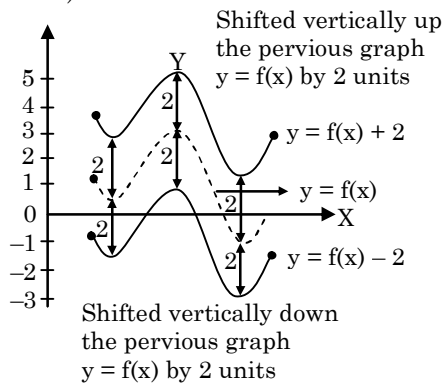

◆ $y = f\left(\frac{x}{a}\right)$ or $y = f(ax)$: (Let $a = 2, 1/2$)

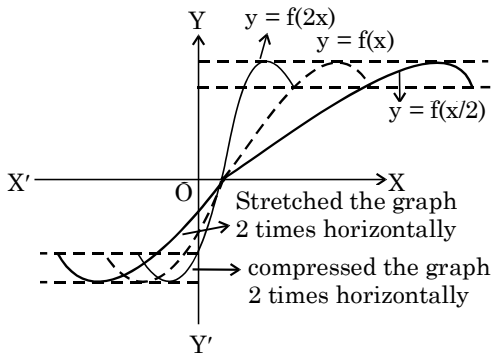

See more examples about the same :

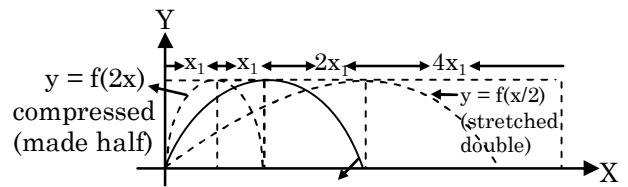

◆ $y = f(-x)$

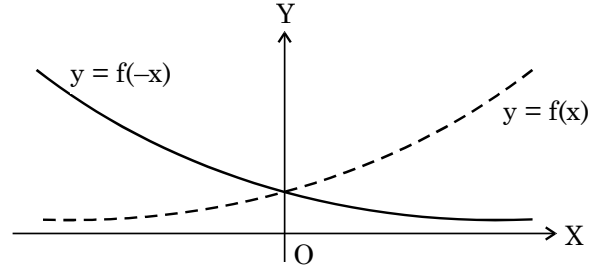

Reflection of $y = f(x)$ w. r. t. axis of y is $y = f(-x)$

◆ To Find $y = k f(x)$

Rule - Stretch the previous graph k times vertically
 e.g. see below $y = 2 \sin x, y = 3 \sin x$

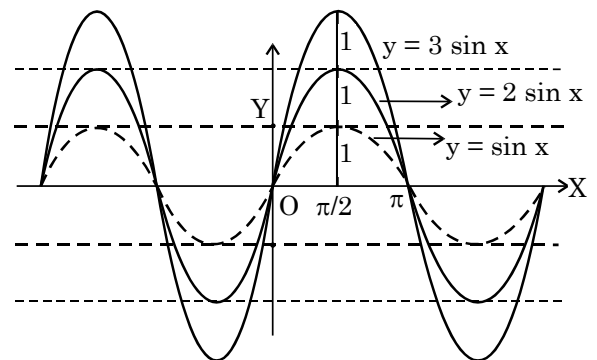

(i) $y = -f(x)$:

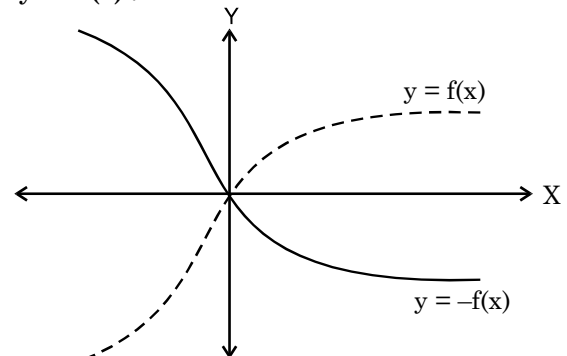

Reflection of $y = f(x)$ w. r. t. axis of x is $y = -f(x)$

◆ To Find $y = f | x |$

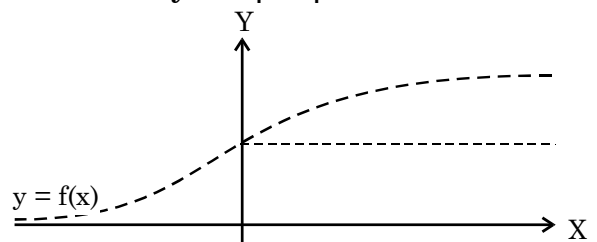

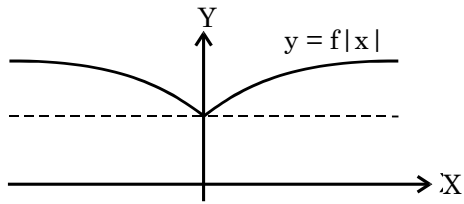

RULE :

Neglect the graph lying in IInd and IIIrd quadrant and, Take the image of graph lying in I and IVth quadrant w. r. t. axis of y.

The original graph including its image is called $y = f |x |$.

Here we took the image of the portion lying in first quadrant about axis of y and left the portion which was lying in second quadrant.

◆ **To Find $y = | f(x) |$**

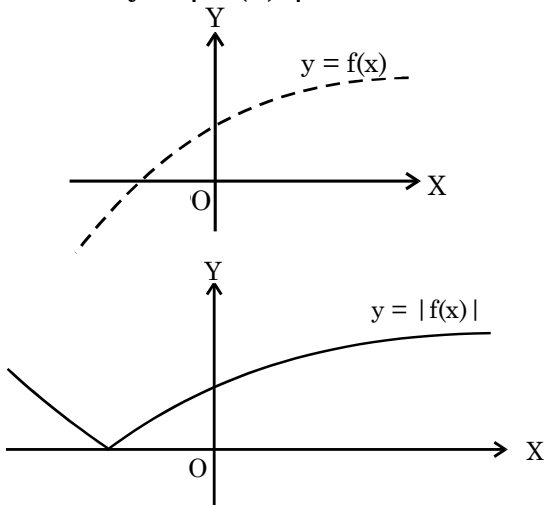

Rule : Take the image of the portion line below axis of x about axis of x. Remain as it is the portion above the axis of x.

Example Based on

Transformation

✎ **Example. 10**

Draw the graph of $| y | = \sin x$

Solution.

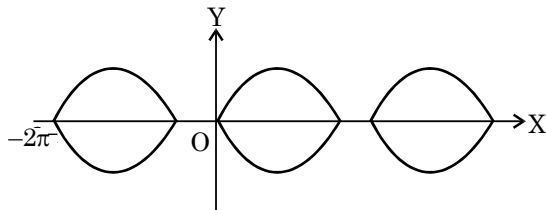

NOTE You can draw $| y | = \sin | x |$ just by taking mirror image of portion lying in I and IV quadrant w.r.t. axis of y.

✎ **Example. 11**

Draw the graph of $| y | = \cos x$

Solution.

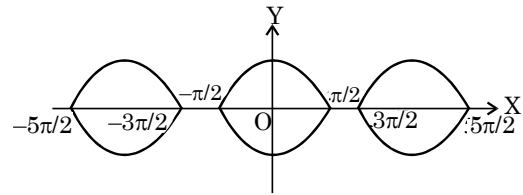

✎ **Example. 12**

Draw $y = e^{-x}$, $y = e^{|x|}$, $y = e^{-|x|}$.

Solution.

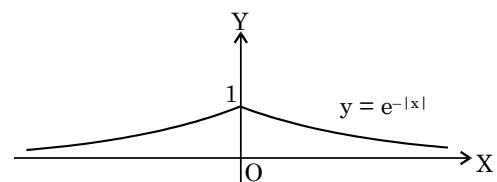
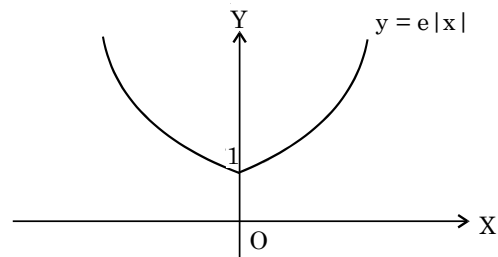
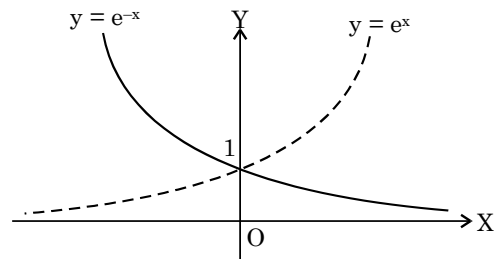

✎ **Example. 13**

Draw $y = -\log_e x$, $y = | \log_e x |$, $y = \log_e | x |$

Solution.

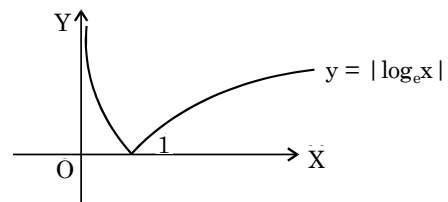
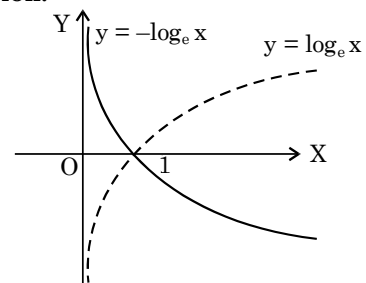

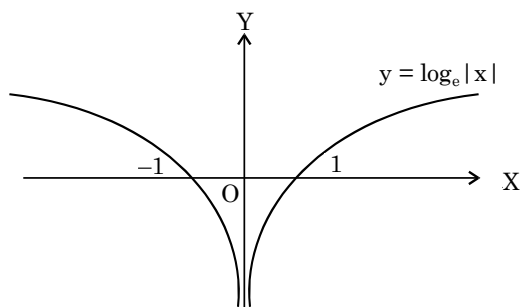

11. ELEMENTARY FUNCTION

If arithmetical operations i.e. (operation of addition, subtraction, multiplication, division) and the operation of function of a function is used finite times over basic elementary function then resulting function is called basic elementary function.

For examples :

$$f(x) = \frac{x^2 \log_e x}{\sin x}$$

$$\phi(x) = \frac{x^2 + e^x + 5}{\sqrt{1 - \cos^{-1} x}}$$

$$\psi(x) = \sin(\sin \sin \log_e x)$$

$$\alpha(x) = \cos(\sin e^x)$$

12. FURTHER REPRESENTATION OF A FUNCTION

◆ Explicit Function

If y be clearly directly defined in terms of x only i.e. $y = f(x)$. Then y is called explicit function of x .

e.g. $y = x^2$, $y = \log_e x$, $y = \tan x$

◆ Implicit Function

A function $y = f(x)$ is said to be an implicit function of x if y cannot be written in terms of x only.

e.g. $ax^2 + by^2 + 2hxy + 2gx + 2fy + c = 0$,

$$xy = \sin(x + y).$$

◆ Parametric Function

If x and y both becomes dependent and they are defined by a new independent variable (say t) as

$$x = \phi(t), \quad y = \psi(t), \quad \text{where } t \text{ is parameter}$$

such functions are called parametric function.

e. g. $x = t^2$, $y = 2t$

NOTE These are not kinds of functions. Simply ways of representing functions.

13. INVERSE FUNCTION

If $f : A \rightarrow B$ be a one-one onto (bijection) function, then the mapping $f^{-1} : B \rightarrow A$ which associates each element $b \in B$ with element $a \in A$, such that $f(a) = b$, is called the inverse function of the function $f : A \rightarrow B$

$$f^{-1} : B \rightarrow A, \quad f^{-1}(b) = a \quad f(a) = b$$

When function is given in ordered pair form then its inverse is defined as -

$$f^{-1} = \{ (b, a) \mid (a, b) \in f \}$$

NOTE

- (1) For the existence of inverse function, it should be one-one and onto.
- (2) One one onto functions are also called bijective. i.e. when the function is surjective as well as injective then function is said to be bijective.

◆ Properties

- (a) Inverse of a bijection is also a bijection function.
- (b) Inverse of a bijection is unique.
- (c) $(f^{-1})^{-1} = f$
- (d) If f and g are two bijections such that $(g \circ f)$ exists then $(g \circ f)^{-1} = f^{-1} \circ g^{-1}$
- (e) If $f : A \rightarrow B$ is a bijection then $f^{-1} : B \rightarrow A$ is an inverse function of f .
 $f^{-1} \circ f = I$ and $f \circ f^{-1} = I$.

Here I , is an identity function ($y = x$ is called an Identity function) i.e.,

$$f^{-1} \circ f = f \circ f^{-1} = x.$$

Example Based on

Inverse Function

Example. 14

If $f : \mathbb{R} \rightarrow \mathbb{R}$, $f(x) = 2x + 3$, then find $f^{-1}(x)$

Solution.

Since f is a bijection therefore its inverse mapping exists if

$$y = 2x + 3 \Rightarrow x = (y - 3) / 2$$

$$\Rightarrow y = \frac{x - 3}{2} \quad \therefore f^{-1}(x) = \frac{x - 3}{2}$$

Example. 15

If $f : \mathbb{R} \rightarrow \mathbb{R}$ where $f(x) = x^2 + 3x + 7$ then find $f^{-1}(7)$.

Solution.

Since $y = f(x)$ is many one therefore inverse of $f(x)$ will not exist i.e. $f^{-1}(7) = \phi$.

Example. 16

If $f : \mathbb{R} \rightarrow \mathbb{R}$, $f(x) = x^3 + 2$ then find $f^{-1}(x)$.

Solution.

$$f(x) = x^3 + 2, \quad x \in \mathbb{R}.$$

Since this is a one-one onto function therefore inverse of this function (f^{-1}) exists.

$$\text{Let } f^{-1}(x) = y$$

$$x = f(y) \Rightarrow x = y^3 + 2 \Rightarrow y = (x - 2)^{1/3}$$

$$f^{-1}(x) = (x - 2)^{1/3}.$$

14. COMPOSITE FUNCTION

Let A , B and C be three non void sets and let $f : A \rightarrow B$, $g : B \rightarrow C$ be two functions. Since f is a function from A to B , therefore for each $x \in A$ there exists a unique element $g(f(x)) \in C$.

Thus, for each $x \in A$ there exists a unique element $g(f(x)) \in C$.

It follows from the above discussion that f and g when considered together define a new function from A to C . This function is called the composition of f and g and is denoted by $g \circ f$. We define it formally as follows -

Definition :

Let $f : A \rightarrow B$ and $g : B \rightarrow C$ be two functions.

Then a function $g \circ f : A \rightarrow C$ defined by

$g \circ f(x) = g(f(x))$ for all $x \in A$ is called the composition of f and g .

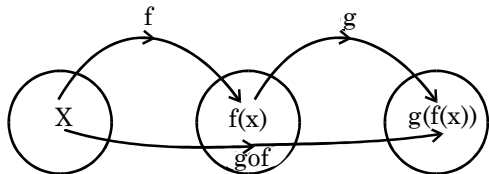

NOTE It is evident from the definition that $g \circ f$ is defined only if for each $x \in A$, $f(x)$ is an element of B so that we can take its g -image. Hence, for the composition $g \circ f$ to exist, the range of f must be a subset of the domain of g .

15. PERIODIC FUNCTION

A function on $y = f(x)$ is said to be periodic. If there exist a series of integral multiple of positive constant (say T) such that

$$f(x + T) = f(x + 2T) = f(x + 3T) = \dots \dots f(x + nT) = f(x).$$

Then period of $f(x)$ is $T, 2T, 3T, 4T, \dots \dots nT$. But fundamental period is T . In numerical problems if the word '**Period**' comes sense goes to fundamental period.



Points to Remember

The function whose period is 2π

- $(\sin x)^{2n+1}, (\cos x)^{2n+1}, (\sec x)^{2n+1}, (\csc x)^{2n+1}$

The function whose period is π

- $(\sin x)^{2n}, (\cos x)^{2n}, (\sec x)^{2n}, (\csc x)^{2n}$
- $(\tan x)^n, (\cot x)^n$
- $|\sin x|, |\cos x|, |\tan x|, |\cot x|, |\sec x|, |\csc x|$
- If $f(x)$ has the period T , then $f(\pm ax + b)$ will have the period $\frac{T}{|a|}$
- If $f_1(x)$ has the period T_1
 $f_2(x)$ has the period T_2
Then period of $af_1(x) + bf_2(x)$ will be

LCM of T_1 and T_2 , provided there should not exist a number ' r ' such that

$$f_1(x + r) = f_2(x) \text{ \& } f_2(x + r) = f_1(x) \text{ and } r \nmid \text{LCM of } T_1 \text{ and } T_2.$$

(In this case period = r) (**Note it**)

e.g. The period of $|\sin x| + |\cos x|$ is $\pi/2$.
LCM of two or more fractional number.

$$\text{LCM of } \frac{a}{b}, \frac{c}{d}, \frac{e}{f} = \frac{\text{LCM of } (a, c, e)}{\text{HCF}(b, d, f)}$$

- Period of $f(x) = T$
 \Rightarrow Period of $1/f(x) = T$

Example Based on Periodic Function

Example. 17

Find the period of $f(x) = x + \sin x - [x]$

Solution.

Given $f(x) = \sin x + \{x$
 $= g(x) + h(x)$

Period of $g(x) = 2\pi$

Period of $h(x) = 1$

2π is irrational and 1 is rational. Therefore LCM will not exist. Note that if irrational quantities be

like $\pi, 2\pi$ or $\pi, \frac{\pi}{3}, \frac{\pi}{6}$ or $\sqrt{3}, 3\sqrt{3}, 9\sqrt{3}$. LCM or

HCF is existing i.e. if there be multiple of a particular irrational quantities then LCM or HCF exist.

Example. 18

Find the period of $f(x) = x - [x - m]$, $m \in \mathbb{I}$, where $[]$ denotes the greatest integer function.

Solution.

Given $f(x) = x - [x - m]$
 $= (x - m) - [x - m] + m$
 $= \{x - m\} + m$

$\therefore \{x - m\}$ is periodic

$\therefore m + \{x - m\}$ will also be periodic and period will be 1.

\therefore Period of $\{x\} =$ Period of $\{x - a\} = 1$

Example. 19

Draw the graph of $y = [\sin x]$ and also find the period, if possible.

Solution.

$$[\sin x] = 0, 0 \leq x < \frac{\pi}{2}$$

$$= 1, x = \frac{\pi}{2}$$

$$= 0, \frac{\pi}{2} < x < \pi$$

$$= -1, \pi \leq x \leq \frac{3\pi}{2}, \dots \dots \dots$$

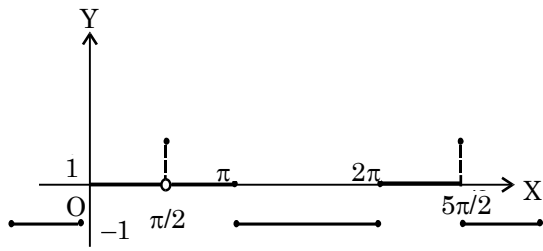

Clearly $f(x)$ is periodic and its period is 2π .

Example. 20

Draw $f(x) = \sin\left[\frac{x}{\pi}\right]$ Is it periodic? If periodic find

its period.

Solution.

$$0 \leq x < \pi \Rightarrow \left[\frac{x}{\pi}\right] = 0$$

$$\pi \leq x < 2\pi \Rightarrow \left[\frac{x}{\pi}\right] = 1$$

$$2\pi \leq x < 3\pi \Rightarrow \left[\frac{x}{\pi}\right] = 2$$

$$3\pi \leq x < 4\pi \Rightarrow \left[\frac{x}{\pi}\right] = 3$$

Clearly $f(x)$ is not periodic.

16. EVEN AND ODD FUNCTIONS

Definition

If, $f(-x) = f(x)$, then $y = f(x)$ is said to be even function and if $f(-x) = -f(x)$, then $y = f(x)$ is called an odd function.

Properties of Even and Odd Function

- The product of two even functions is even function.
- The sum and difference of two even functions is even function.
- The sum and difference of two odd functions is odd function.
- The product of two odd functions is even function.
- The product of an even and an odd function is odd function.
- The sum of even and odd function is neither even nor odd function.
- It is not essential that every function is even or odd. It is possible to have some functions which are neither even nor odd function.
- Even functions are symmetric w.r.t. y-axis and odd functions are symmetric w.r.t. origin.

e.g. $f(x) = x^2 + x^3$, $f(x) = \log_e x$, $f(x) = e^x$

Neither odd nor even functions.

e.g. $f(x) = \cos x$, $f(x) = \sec x$, $f(x) = x^4$, these are the examples of even functions.

e.g. $f(x) = \sin x$, $f(x) = \cot x$, $f(x) = x^3$, these are the examples of odd functions.

NOTE Zero function $f(x) = 0$ is the only function which is even and odd both.

Example Based on

Even and Odd Function

Example. 21

If $f(x) = \frac{a^x + 1}{a^x - 1}$ then is it an even or odd function -

Solution.

$$f(-x) = \frac{a^{-x} + 1}{a^{-x} - 1} = -\frac{a^x + 1}{a^x - 1}$$

$$\therefore f(-x) = -f(x)$$

$\therefore f(x)$ is an odd function.

17. ALGEBRAIC FUNCTION

Rational Integral Function or Polynomial:

A function having the form

$$y = a_0 + a_1x + a_2x^2 + a_3x^3 + \dots + a_nx^n, \text{ where } a_0, a_1, a_2, \dots, a_n$$

are real constant called rational integral function or polynomial of degree n .

Fractional Rational Function :

The ratio of two polynomial is called Fraction Rational function or simply rational function.

$$\text{e.g. } y = \frac{x^{12} + x^2 - 1}{x^6 + x^4 + 1}$$

Irrational Function :

Functions with operations of addition, subtraction, multiplication, division and raising to power with non-integral rational exponent are called irrational functions.

$$y = \sqrt{x}, y = \frac{\sqrt{x^3 + 1} - \sqrt{x^{11}}}{\sqrt{x^2 + x + 1}}$$

$$y = \frac{x^{17/3} + x^{103/7} - x}{\sqrt[3]{x^{17} + x^5} - 3}$$

$$y = \frac{\sqrt{\sqrt{x^2 + 5} + x^{16.5} + x^{1/3}}}{\sqrt{x^2 - 7} - \sqrt{\sqrt{x^{2/3}} - 1}}$$

Such type of function are called **Irrational function**.

◆ **Transcendental Function :**

The function which are not algebraic called transcendental function.

e.g. $f(x) = \sin x$

$$y = \cos^{-1}x$$

$$y = \log_e x, y = \sqrt{\log_e x - \sin^{-1} x}$$

$$y = \frac{\log_e x + \tan x}{\sin^{-1} x + 2^x} \text{ etc.}$$

18. BOUNDED FUNCTION

The function $f(x)$ is said to be bounded above if there exists M such that $y = f(x) \leq M$ (i.e. not greater than M) for all x of the domain and M is called upper bound. Similarly $f(x)$ is said to be bounded below if there exists m such that $y = f(x) \geq m$ (i.e. never less than m) for all x of the domain and m is called the lower bound.

If however, there does not exist M and m as stated above, the function is said to be unbounded.

19. EXTENSION OF A FUNCTION

Let $f : A \rightarrow B$ s. t. $f(x) = y \forall x \in A$

If $X \supset A$ i.e. X is a super set of A and $Y \supset f(A)$ then another function

$g : X \rightarrow Y$ s. t. $g(x) = f(x) \forall x \in A$
is called an extension of f from A to X .

◆ **Even and Odd extension**

Let $f(x)$ be a function defined on $A = [0, a]$ and $X = [-a, a]$ is a super set of A then an extension of $f(x)$ on $X = [-a, a]$ will be even or odd extension if $f(x)$ becomes an even or odd function on X .

Example Based on

Extension of Function

✎ **Example. 22**

Let $f(x) = x^2 + 5x - 2$ defined on $A = [0, 2]$. Find even and odd extension of $f(x)$ in $[-2, 2]$

Solution.

$$f(x) = x^2 + 5x - 2, \quad f(-x) = x^2 - 5x - 2$$

Let g_e and g_o denote even and odd extension

$$g_e(x) =$$

$$\begin{cases} f(x) : x \in [0, 2] \\ f(-x) : x \in [-2, 0] [\because f(-x) = f(x) \text{ for even}] \end{cases}$$

$$g_o(x) =$$

$$\begin{cases} f(x) : x \in [0, 2] \\ -f(-x) : x \in [-2, 0] [\because -f(-x) = f(x) \text{ for odd}] \end{cases}$$

$$g_e(x) = \begin{cases} x^2 + 5x - 2 & : x \in [0, 2] \\ x^2 - 5x - 2 & : x \in [-2, 0[\end{cases}$$

$$g_o(x) = \begin{cases} x^2 + 5x - 2 & : x \in [0, 2] \\ -x^2 + 5x + 2 & : x \in [-2, 0[\end{cases}$$

SOLVED EXAMPLES

Ex.1 Find the domain and range of the function

$$f(x) = \sqrt{2-x} + \sqrt{1+x}$$

Sol. Domain of $f(x) = \{x \mid 2-x \geq 0 \text{ and } 1+x \geq 0\}$

$$\therefore \text{domain of } f(x) = [-1, 2]$$

$$\begin{aligned} \text{Again, } \{f(x)\}^2 &= (\sqrt{2-x} + \sqrt{1+x})^2 \\ &= 3 + 2\sqrt{(2-x)(1+x)} \\ &= 3 + 2\sqrt{2+x-x^2} \\ &= 3 + 2\sqrt{\frac{9}{4} - \left(x - \frac{1}{2}\right)^2} \end{aligned}$$

\therefore the greatest value of $\{f(x)\}^2$

$$= 3 + 2\sqrt{\frac{9}{4}} = 6, \text{ when } x = \frac{1}{2}$$

the least value of $\{f(x)\}^2 = 3 + 0 = 3$,

$$\text{when } x - \frac{1}{2} = \frac{3}{2}, \text{ i.e. } x = 2$$

\therefore the greatest value of $f(x) = \sqrt{6}$

and the least value of $f(x) = \sqrt{3}$

\therefore range of $f(x) = [\sqrt{3}, \sqrt{6}]$

Ex.2 Find the range of the following function

$$f(x) = \frac{3}{2-x^2}$$

Sol. Let $y = \frac{3}{2-x^2} = f(x)$ (1)

The function y is not defined for

$$x = \pm \sqrt{2}$$

$$\text{From (1), } x^2 = \frac{2y-3}{y}$$

since for real x , $x^2 \geq 0$,

$$\text{We have } \frac{2y-3}{y} \geq 0$$

$\therefore y \geq 3/2$ or $y < 0$ (Note that $y \neq 0$)

Hence the range of the function is

$$]-\infty, 0[\cup [3/2, \infty)$$

Ex.3 Find the range of the following function:

$$f(x) = \log_2 \left(\frac{\sin x - \cos x + 3\sqrt{2}}{\sqrt{2}} \right)$$

Sol. $\therefore f(x) = \log_2 \left(\frac{\sin x - \cos x + 3\sqrt{2}}{\sqrt{2}} \right)$

$$= \log_2 \left(\sin \left(\pi - \frac{\pi}{4} \right) + 3 \right) = y \text{ (let)}$$

$$\Rightarrow 2^y = \sin \left(\pi - \frac{\pi}{4} \right) + 3$$

$$\Rightarrow 2^y - 3 = \sin \left(\pi - \frac{\pi}{4} \right)$$

$$\text{But } -1 \leq \sin \left(\pi - \frac{\pi}{4} \right) \leq 1$$

$$\therefore -1 \leq 2^y - 3 \leq 1$$

$$\Rightarrow 2 \leq 2^y \leq 4$$

$$\Rightarrow 2^1 \leq 2^y \leq 2^2$$

Hence $y \in [1, 2]$.

Hence Range of $f(x)$ is $[1, 2]$.

Ex.4 Find the period of the following function

$$f(x) = e^{x-[x]} + |\cos \pi x| + |\cos 2\pi x| + \dots + |\cos n\pi x|,$$

[.] is greatest integer function.

Sol. $f(x) = e^{x-[x]} + |\cos \pi x| + |\cos 2\pi x| + \dots + |\cos n\pi x|$

Period of $x - [x] = 1$

Period of $|\cos \pi x| = 1$

Period of $|\cos 2\pi x| = 1/2$

.....

.....

Period of $|\cos n\pi x| = 1/n$

So period of $f(x)$ will be

L.C.M. of all periods = 1.

Ex.5 Let a function $f : \mathbb{R} \rightarrow \mathbb{R}$ be defined as $f(x) = x - [x]$, (where $[x]$ is a greatest integer $\leq x$), for all $x \in \mathbb{R}$. Is the function bijective?

Sol. Let $x_1, x_2 \in \mathbb{R}$

$$f(x_1) = f(x_2) \Rightarrow x_1 - [x_1] = x_2 - [x_2]$$

$$\Rightarrow x_1 \neq x_2$$

\therefore The function is not bijective.

Ex.6 If $f(x) = \begin{cases} x^3 + 1, & x < 0 \\ x^2 + 1, & x \geq 0 \end{cases}$,

$$g(x) = \begin{cases} (x-1)^{1/3}, & x < 1 \\ (x-1)^{1/2}, & x \geq 1 \end{cases}$$

Compute $\text{gof}(x)$.

Sol. We have

$$\text{gof}(x) = g(f(x))$$

Ex.7 The value of $n \in \mathbb{I}$ for which the function

$$f(x) = \frac{\sin nx}{\sin(x/n)}$$

has 4π as its period is -

- (A) 2 (B) 3 (C) 5 (D) 4

Sol. For $n = 2$,
 we have $\frac{\sin 2x}{\sin(x/2)} = 4(\cos x/2) \cos x$.
 The period of $\cos x$ is 2π , & that of $\cos(x/2)$ is 4π .
 Hence the period of $\frac{\sin 2x}{\sin(x/2)}$ is 4π .
 Also, the period of $\frac{\sin 3x}{\sin(x/3)}$, $\frac{\sin 5x}{\sin(x/5)}$ and
 $\frac{\sin 4x}{\sin(x/4)}$ cannot be 4π . **Ans. [A]**

Ex.8 Prove that even functions do not have inverse.
Sol. Even functions are many one function and for the existence of inverse function should be one-one. Hence inverse of an even function will not exist.

Ex.9 Prove that periodic functions do not have inverse.

Sol. $f(x)$ is periodic
 $\Rightarrow f$ is many one
 $\Rightarrow f^{-1}$ does not exist.
 $= \begin{cases} g(x^3 + 1), & x < 0 \\ g(x^2 + 1), & x \geq 0 \end{cases}$
 $= \begin{cases} (x^3 + 1 - 1)^{1/3} & x < 0 \\ (x^2 + 1 - 1)^{1/2}, & x \geq 0 \end{cases}$
 $= \begin{cases} x, & x < 0 \\ x, & x \geq 0 \end{cases} = x \text{ for all } x.$

Hence, $gof(x) = x$ for all x .

Ex.10 Show that the function $f : R \rightarrow R$ defined by $f(x) = 3x^3 + 5$ for all $x \in R$ is a bijection.

Sol. Injectivity : Let x, y be any two elements of $R(\text{domain})$.
 Then,
 $f(x) = f(y) \Rightarrow 3x^3 + 5 = 3y^3 + 5$
 $\Rightarrow x^3 = y^3 \Rightarrow x = y$
 Thus, $f(x) = f(y)$
 $\Rightarrow x = y$ for all $x, y \in R$.
 so, f is an injective map.
 Surjectivity : Let y be an arbitrary element of $R(\text{co-domain})$.
 Then,
 $f(x) = y \Rightarrow 3x^3 + 5 = y \Rightarrow x^3 = \frac{y-5}{3}$
 $\Rightarrow x = \left(\frac{y-5}{3}\right)^{1/3}$

Thus we find that for all $y \in R$ (co-domain) there exists $x = \left(\frac{y-5}{3}\right)^{1/3} \in R$ (domain) such that

$$f(x) = f\left(\left(\frac{y-5}{3}\right)^{1/3}\right) = 3\left[\left(\frac{y-5}{3}\right)^{1/3}\right]^3 + 5$$

$$= y - 5 + 5 = y$$

This shows that every element in the co-domain has its pre-image in the domain. So, f is a surjection. Hence, f is a bijection.

Ex.11 Let, $f(x) = x + 1, \quad x \leq 1$
 $= 2x + 1, \quad 1 < x \leq 2$
 $g(x) = x^2, \quad -1 \leq x < 2$
 $= x + 2, \quad 2 \leq x \leq 3$

Find fog and gof .

Sol. $f\{g(x)\} = g(x) + 1, \quad g(x) \leq 1$
 $= 2g(x) + 1, \quad 1 < g(x) \leq 2$
 $\Rightarrow f\{g(x)\} = x^2 + 1, \quad -1 \leq x \leq 1$
 $= 2x^2 + 1, \quad 1 < x \leq \sqrt{2}$
 $g\{f(x)\} = \{f(x)\}^2, \quad -1 \leq f(x) < 2$
 $= f(x) + 2, \quad 2 \leq f(x) \leq 3$
 $gof(x) = (x + 1)^2, \quad -2 \leq x < 1$
 $= (x + 1)^2 \quad -2 \leq x \leq 1$

Ex.12 Find the inverse of the following function :

$$f(x) = \begin{cases} x, & x < 1 \\ x^2, & 1 \leq x \leq 4 \\ 8\sqrt{x}, & x > 4 \end{cases}$$

Sol. Let $f(x) = \begin{cases} x, & x < 1 \\ x^2, & 1 \leq x \leq 4 \\ 8\sqrt{x}, & x > 4 \end{cases}$

Let $f(x) = y \quad \therefore x = f^{-1}(y)$

$$\Rightarrow x = \begin{cases} y, & y < 1 \\ \sqrt{y}, & 1 \leq y \leq 16 \\ y^2/64, & y > 16 \end{cases}$$

$$\Rightarrow f^{-1}(y) = \begin{cases} y, & y < 1 \\ \sqrt{y}, & 1 \leq y \leq 16 \\ y^2/64, & y > 16 \end{cases}$$

$$\Rightarrow f^{-1}(x) = \begin{cases} x, & x < 1 \\ \sqrt{x}, & 1 \leq x \leq 16 \\ x^2/64, & x > 16 \end{cases}$$

Ex.13 Let $f(x) = x^2 + x$ be defined on the interval $[0, 2]$. Find the odd and even extensions of $f(x)$ in the interval $[-2, 2]$.

Sol. Odd extension.

$$f(x) = \begin{cases} f(x), & 0 \leq x \leq 2 \\ -f(-x), & -2 \leq x < 0 \end{cases}$$

$$= \begin{cases} x^2 + x, & 0 \leq x \leq 2 \\ -x^2 + x, & -2 \leq x < 0 \end{cases}$$

Even extension

$$f(x) = \begin{cases} f(x), & 0 \leq x \leq 2 \\ f(-x), & -2 \leq x < 0 \end{cases}$$

$$= \begin{cases} x^2 + x, & 0 \leq x \leq 2 \\ x^2 - x, & -2 \leq x < 0 \end{cases}$$

Ex.14 Let $f: R \rightarrow R$ be given by

$f(x) = (x+1)^2 - 1, x \geq -1$. Show that f is invertible. Also, find the set

$$S = \{x : f(x) = f^{-1}(x)\}.$$

Sol. In order to show that $f(x)$ is invertible, it is sufficient to show that $f(x)$ is a bijection.

f is an injection : For any $x, y \in R$ satisfying $x \geq -1, y \geq -1$,

We have $f(x) = f(y)$

$$\Rightarrow (x+1)^2 - 1 = (y+1)^2 - 1$$

$$\Rightarrow x^2 + 2x = y^2 + 2y$$

$$\Rightarrow x^2 - y^2 = -2(x-y)$$

$$\Rightarrow (x-y)(x+y) = -2(x-y)$$

$$\Rightarrow (x-y)[x+y+2] = 0$$

$$\Rightarrow x-y=0 \text{ or } x+y+2=0$$

$$\Rightarrow x=y \text{ or } x=y=-1$$

Thus, $f(x) = f(y) \Rightarrow x = y$ for all

$x \geq -1, y \geq -1$.

So, $f(x)$ is an injection.

f is a surjection : For all $y \geq -1$ there exists.

$$x = -1 + \sqrt{y+1} \geq -1 \text{ such that } f(x) = y$$

So, $f(x)$ is a surjection.

Hence, f is a bijection. Consequently, it is invertible.

$$f(x) = f^{-1}(x) \Rightarrow f(x) = x$$

$$(x+1)^2 - 1 = x \Rightarrow x = 0, -1$$

Ex.15 If f, g, h are function from R to R such that

$$f(x) = x^2 - 1, g(x) = \sqrt{x^2 + 1},$$

$$h(x) = 0, \text{ if } x \leq 0$$

$$= x, \text{ if } x \geq 0$$

then find the composite function $h \circ (f \circ g)$ and determine whether the function $f \circ g$ is invertible and the function h is the identity function.

Sol. Here $f(x) = x^2 - 1$ for all x

and $g(x) = \sqrt{x^2 + 1}$ for all x

$$\therefore f \{g(x)\} = \{g(x)\}^2 - 1$$

$$= x^2 + 1 - 1 = x^2 \text{ for all } x$$

$$\therefore h \{f \{g(x)\}\} = h(x^2) = x^2$$

because $x^2 \geq 0$ [from definition of $h(x)$.]

Now, $f \{g(x)\} = x^2$ for all x

As $x^2 \geq 0$, $(f \circ g)(x)$ cannot be negative.

So $f \circ g$ is not an onto function.

Hence $f \circ g$ is not invertible.

Again, $h(x) = x$ for $x \geq 0$.

But, by definition $h(x) \neq x$ for $x < 0$.

Hence h is not the identity function.

Ex.16 Let $f(x) = \tan x, x \in \left[-\frac{\pi}{2}, \frac{\pi}{2}\right]$ and

$$g(x) = \sqrt{1-x^2}. \text{ Determine } f \circ g \text{ and } g \circ f.$$

Sol. From the given domain of $f \left[-\frac{\pi}{2}, \frac{\pi}{2}\right]$ we

conclude that its range $]-\infty, \infty[$ [i.e. whole of R

Domain of g is $1-x^2 \geq 0$ or $x^2 - 1 \leq 0$

or $(x+1)(x-1) \leq 0$ or $-1 \leq x \leq 1$ or $[-1, 1]$

and for range of $g, y = \sqrt{1-x^2}$

since $x^2 \leq 1 \therefore y \in [0, 1]$

$$(f \circ g)x = f(g(x)) = f\{\sqrt{1-x^2}\}$$

$$= f(t), \text{ where } t = \sqrt{1-x^2} \in [0, 1]$$

range of $g \subset \left[-\frac{\pi}{2}, \frac{\pi}{2}\right]$ which is domain of f .

$$= \tan t = \tan \sqrt{1-x^2}$$

$(g \circ f)x = g(f(x)) = g(\tan x) = g(t)$ where $t = \tan x \in \text{range of } f = R$. But R is not a subset of domain of $g = [-1, 1]$

Hence $g \circ f$ is not defined.

Ex.17 Let $f_1(x) = \frac{x}{3} + 10$ for all $x \in R$, and

$f_n(x) = f_1(f_{n-1}(x))$ for $n \geq 2$. Then find $f_n(x)$.

Sol. We have

$$f_n(x) = f_1(f_{n-1}(x)), n \geq 2$$

$$\Rightarrow f_2(x) = f_1(f_1(x)) = \frac{1}{3} f_1(x) + 10$$

$$= \frac{1}{3} \left(\frac{x}{3} + 10 \right) + 10$$

$$= \frac{x}{3^2} + \frac{10}{3} + 10$$

$$f_3(x) = f_1(f_2(x))$$

$$= \frac{1}{3} f_2(x) + 10$$

$$= \frac{1}{3} \left(\frac{x}{3^2} + \frac{10}{3} + 10 \right) + 10$$

$$= \frac{x}{3^3} + \frac{10}{3^2} + \frac{10}{3} + 10$$

$$\begin{aligned}
 f_4(x) &= f_1(f_3(x)) = \frac{1}{3}f_3(x) + 10 \\
 &= \frac{1}{3}\left(\frac{x}{3^3} + \frac{10}{3^2} + \frac{10}{3} + 10\right) + 10 \\
 &= \frac{x}{3^4} + \frac{10}{3^3} + \frac{10}{3^2} + \frac{10}{3} + 10
 \end{aligned}$$

Continuing in this manner, we obtain

$$\begin{aligned}
 f_n(x) &= \frac{x}{3^n} + \frac{10}{3^{n-1}} + \frac{10}{3^{n-2}} + \dots + \frac{10}{3} + 10 \\
 &= \frac{x}{3^n} + 10 \left(\frac{1 - \frac{1}{3^n}}{1 - \frac{1}{3}} \right) \\
 &= \frac{x}{3^n} + 15 \left(1 - \frac{1}{3^n} \right) = \frac{x - 15}{3^n} + 15
 \end{aligned}$$

Ex.18 Knowing the graph of $y = f(x)$ draw
 $y = \frac{f(x) + |f(x)|}{2}$ and $y = \frac{f(x) - |f(x)|}{2}$

Sol. Let graph

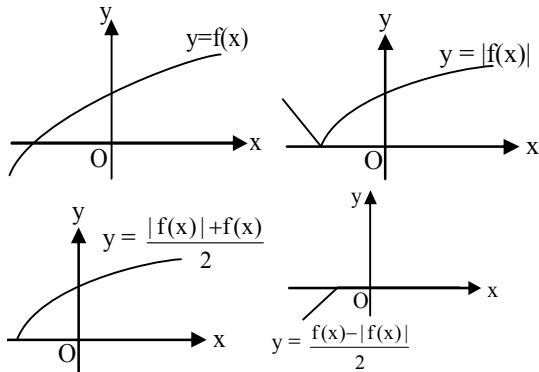

Ex.19 Draw following graphs:

(i) $|y| = \cos x$ (ii) $|y| = \sin x$

Sol. (i) $|y| = \cos x$

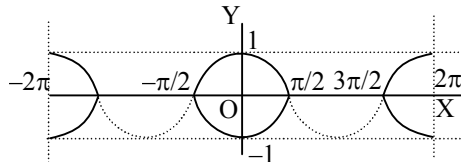

(ii) $|y| = \sin x$

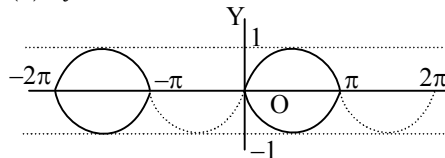

EXERCISE (Level-1)

Question based on

Domain

- Q.1** Domain of $y = \log_{10} \left(\frac{5x - x^2}{4} \right)$ is
- (A) (0, 5)
 (B) [1, 4]
 (C) $(-\infty, 0) \cup (5, \infty)$
 (D) $(-\infty, 1) \cup (4, \infty)$
- Q.2** The domain of definition of $f(x) = \frac{\sqrt{-\log_{0.3}(x-1)}}{\sqrt{x^2 + 2x + 8}}$ is:
- (A) (1, 4) (B) (-2, 4)
 (C) (2, 4) (D) [2, ∞)
- Q.3** The function $f(x) = \cot^{-1} \sqrt{(x+3)x} + \cos^{-1} \sqrt{x^2 + 3x + 1}$ is defined on the set S, where S is equal to:
- (A) {0, 3} (B) (0, 3)
 (C) {-3, 0} (D) [-3, 0]
- Q.4** The domain of $\sqrt{\sec^{-1} \left(\frac{2-|x|}{4} \right)}$ is
- (A) R (B) $R - (-1, 1)$
 (C) $R - (-3, 3)$ (D) $R - (-6, 6)$
- Q.5** The domain of the function $f(x) = {}^{24-x}C_{3x-1} + {}^{40-6x}C_{8x-10}$ is -
- (A) {2, 3} (B) {1, 2, 3}
 (C) {1, 2, 3, 4} (D) None of these
- Q.6** Domain of the function $f(x) = (1-3x)^{1/3} + 3\cos^{-1} \left(\frac{2x-1}{3} \right) + 3^{3\tan^{-1}x}$ is
- (A) $\left[-\frac{1}{3}, \frac{1}{3} \right]$ (B) $\left[-\frac{1}{2}, 1 \right]$
 (C) [-1, 2] (D) $\left[-\frac{1}{4}, \frac{1}{2} \right]$
- Q.7** The function $f(x) = \frac{\sec^{-1}x}{\sqrt{x-[x]}}$, where [x] denotes the greatest integer less than or equal to x, is defined for all x belonging to -
- (A) R
 (B) $R - \{(-1, 1) \cup \{n : n \in \mathbb{Z}\}\}$
 (C) $R^+ - (0, 1)$
 (D) $R^+ - \{n : n \in \mathbb{N}\}$

Q.8

The function

$$f(x) = \cos^{-1} \left(\frac{|x|-3}{2} \right) + [\log_e(4-x)]^{-1}$$

is defined for -

- (A) $[-1, 0] \cup [1, 5]$
 (B) $[-5, -1] \cup [1, 4]$
 (C) $[-5, -1] \cup ([1, 4] - \{3\})$
 (D) $[1, 4] - \{3\}$

Q.9

The domain of function $f(x) = \log |\log x|$ is -

- (A) (0, ∞) (B) (1, ∞)
 (C) $(0, 1) \cup (1, \infty)$ (D) $(-\infty, 1)$

Q.10

The domain of function

$$f(x) = \frac{1}{\log_{10}(3-x)} + \sqrt{x+2}$$

- is -
- (A) [-2, 3] (B) $[-2, 3] - \{2\}$
 (C) [-3, 2] (D) $[-2, 3] - \{2\}$

Question based on

Range

- Q.11** The range of the function $y = \frac{1}{2 - \sin 3x}$ is :
- (A) $\left(\frac{1}{3}, 1 \right)$ (B) $\left[\frac{1}{3}, 1 \right]$
 (C) $\left[\frac{1}{3}, 1 \right]$ (D) None of these
- Q.12** The value of the function $f(x) = \frac{x^2 - 5x + 6}{x^2 - 4x + 3}$ lies in the interval -
- (A) $(-\infty, \infty) - \left\{ \frac{1}{2}, 1 \right\}$ (B) $(-\infty, \infty)$
 (C) $(-\infty, \infty) - \{1\}$ (D) None of these
- Q.13** The range of the function, $y = \log_{\sqrt{7}}(\sqrt{2}(\sin x - \cos x) + 5)$ is
- (A) R (B) Z
 (C) $[\log_7 4, \log_7 5]$ (D) $[2 \log_7 3, 2]$
- Q.14** Which of the following function(s) has the range [-1, 1]
- (A) $f(x) = \cos(2 \sin x)$
 (B) $g(x) = \cos \left(1 - \frac{1}{1+x^2} \right)$
 (C) $h(x) = \sin(\log_2 x)$
 (D) $k(x) = \tan(e^x)$

- Q.15** The range of the function $f(x) = \cos(\cos^{-1}\{x\})$ is (where $\{ \cdot \}$ denotes the fractional part function)
 (A) $[0, 1]$ (B) $[0, 1]$
 (C) $(0, 1)$ (D) $(0, 1]$

- Q.16** Let $f(x) = \frac{x - [x]}{1 - [x] + x}$, then range of $f(x)$ is- (where $[\cdot]$ represent greatest integer function)
 (A) $[0, 1]$ (B) $\left[0, \frac{1}{2}\right]$
 (C) $\left[\frac{1}{2}, 1\right]$ (D) $\left[0, \frac{1}{2}\right)$

- Q.17** The range of the function $y = \log_3(5 + 4x - x^2)$ is-
 (A) $(0, 2]$ (B) $(-\infty, 2]$
 (C) $(0, 9]$ (D) None of these

Question based on

Classification of functions

- Q.18** Let $f: R \rightarrow R$ be a function defined by $f(x) = \frac{x^2 + 2x + 5}{x^2 + x + 1}$ is :
 (A) one-one and into
 (B) one-one and onto
 (C) many-one and onto
 (D) many-one and into
- Q.19** The function $f: [2, \infty) \rightarrow Y$ defined by $f(x) = x^2 - 4x + 5$ is both one-one & onto if:
 (A) $Y = R$ (B) $Y = [1, \infty)$
 (C) $Y = [4, \infty)$ (D) $Y = [5, \infty)$
- Q.20** Let $f: R \rightarrow R$ be a function defined by $f(x) = x^3 + x^2 + 3x + \sin x$. Then f is :
 (A) one - one & onto (B) one - one & into
 (C) many one & onto (D) many one & into
- Q.21** Which of the following function from $A = \{x: -1 \leq x \leq 1\}$ to itself are bijections-
 (A) $f(x) = \frac{x}{2}$ (B) $g(x) = \sin\left(\frac{\pi x}{2}\right)$
 (C) $h(x) = |x|$ (D) $k(x) = x^2$
- Q.22** If $f: \left[\frac{\pi}{4} - \frac{1}{2}, \frac{3\pi}{4} - \frac{1}{2}\right] \rightarrow [-1, 1]$ is defined by $f(x) = \sin(2x + 1)$, then f is
 (A) one one into (B) many one onto
 (C) one one onto (D) many one into
- Q.23** The number of bijective functions from set A to itself when A contains 106 elements is
 (A) 106 (B) 106!
 (C) 106^{106} (D) $106^{106} - 106!$

Question based on

Inverse function

- Q.24** If $f(x) = x^3 - 1$ and domain of $f = \{0, 1, 2, 3\}$, then domain of f^{-1} is -
 (A) $\{0, 1, 2, 3\}$ (B) $\{1, 0, -7, -26\}$
 (C) $\{-1, 0, 7, 26\}$ (D) $\{0, -1, -2, -3\}$
- Q.25** The inverse of the function $y = \frac{e^x - e^{-x}}{e^x + e^{-x}}$ is
 (A) $\frac{1}{2} \log \frac{1+x}{1-x}$ (B) $\frac{1}{2} \log \frac{2+x}{2-x}$
 (C) $\frac{1}{2} \log \frac{1-x}{1+x}$ (D) $2 \log(1+x)$

Question based on

Composite function

- Q.26** The function $f(x)$ is defined in $[0, 1]$ then the domain of definition of the function $f[\ln(1-x^2)]$ is given by :
 (A) $x \in \{0\}$
 (B) $x \in [-\sqrt{1+e}-1] \cup [1+\sqrt{1+e}]$
 (C) $x \in (-\infty, \infty)$
 (D) None of these
- Q.27** If $f: R \rightarrow R$, $f(x) = x^3 + 3$, and $g: R \rightarrow R$, $g(x) = 2x + 1$, then $f^{-1} \circ g^{-1}(23)$ equals-
 (A) 2 (B) 3
 (C) $(14)^{1/3}$ (D) $(15)^{1/3}$
- Q.28** If $f(x) = e^{3x}$ and $g(x) = \ln x$, $x > 0$, then $(f \circ g)(x)$ is equal to-
 (A) $3x$ (B) x^3
 (C) $\log 3x$ (D) $3 \log x$
- Q.29** If $f(x) = x^3 - x$ and $g(x) = \sin 2x$, then-
 (A) $g[f(1)] = 1$ (B) $f\left(g\left(\frac{\pi}{12}\right)\right) = -\frac{3}{8}$
 (C) $g\{f(2)\} = \sin 2$ (D) None of these

Question based on

Periodic function

- Q.30** If $f: R \rightarrow R$ is a function satisfying the property $f(x+1) + f(x+3) = 2 \forall x \in R$ then the period (may not be fundamental period) of $f(x)$ is
 (A) 3 (B) 4 (C) 7 (D) 6
- Q.31** The fundamental period of the function:
 $f(x) = x + a - [x + b] + \sin \pi x + \cos 2\pi x$
 $+ \sin 3\pi x + \cos 4\pi x + \dots + \sin(2i-1)\pi x$
 $+ \cos 2n\pi x$ for every $a, b \in R$ is:
 (where $[\cdot]$ denotes the greatest integer function)
 (A) 2 (B) 4 (C) 1 (D) 0

- Q.32** Let $f(x) = \sin \sqrt{[a]} x$ (where $[]$ denotes the greatest integers function). If f is periodic with fundamental period π , then a belongs to -
 (A) $[2, 3)$ (B) $\{4, 5\}$
 (C) $[4, 5)$ (D) $[4, 5]$
- Q.33** The function $f(x) = \left| \cos^5 \left(\frac{x}{2} \right) \right|$ is periodic with fundamental period
 (A) π (B) 2π
 (C) $\frac{\pi}{2}$ (D) 4π
- Q.34** The fundamental period of $f(x) = \cos(\sin x) + \cos(\cos x)$ is
 (A) $\frac{\pi}{3}$ (B) $\frac{\pi}{6}$
 (C) π (D) $\frac{\pi}{2}$
- Q.35** Fundamental period of the function $f(x) = |\sin \pi x| + e^{3(x - [x])}$ (where $[]$ represent greatest integer function) is -
 (A) 1 (B) 2
 (C) $\frac{1}{3}$ (D) None of these

Question based on

Even and odd function

- Q.36** Which of the following is an even function?
 (A) $x \frac{a^x - 1}{a^x + 1}$ (B) $\tan x$
 (C) $\frac{a^x - a^{-x}}{2}$ (D) $\frac{a^x + 1}{a^x - 1}$
- Q.37** Which of the following function is an odd function
 (A) $f(x) = \sqrt{1+x+x^2} - \sqrt{1-x+x^2}$
 (B) $f(x) = x \left(\frac{a^x + 1}{a^x - 1} \right)$
 (C) $f(x) = \log \left(\frac{1-x}{1+x^2} \right)$
 (D) $f(x) = k$ (constant)

Question based on

Miscellaneous points

- Q.38** The set of points for which $f(x) = \cos(\sin x) > 0$ contains -
 (A) $(-\infty, 0]$ (B) $[-1, 1]$
 (C) $(-\infty, \infty)$ (D) All are correct
- Q.39** If $[x]$ stands for the greatest integer function, then the value of
 $\left[\frac{1}{2} + \frac{1}{1000} \right] + \left[\frac{1}{2} + \frac{2}{1000} \right] + \dots + \left[\frac{1}{2} + \frac{999}{1000} \right]$
 (A) 498 (B) 499
 (C) 500 (D) 501
- Q.40** Let the function $f(x) = 3x^2 - 4x + 8 \log(1 + |x|)$ be defined on the interval $[0, 1]$. The even extension of $f(x)$ to the interval $[-1, 0]$ is -
 (A) $3x^2 + 4x + 8 \log(1 + |x|)$
 (B) $3x^2 - 4x + 8 \log(1 + |x|)$
 (C) $3x^2 + 4x - 8 \log(1 + |x|)$
 (D) $3x^2 - 4x - 8 \log(1 + |x|)$
- Q.41** Let $f: \mathbb{N} \rightarrow \mathbb{N}$ where $f(x) = x + (-1)^{x-1}$ then f is -
 (A) Inverse of itself (B) Even function
 (C) Periodic (D) Identity

EXERCISE (Level-2)

Single correct answer type questions

- Q.1** If fundamental period of $\frac{\cos(\sin nx)}{\tan(x/n)}$ ($n \in N$) is 6π then n is equal to
 (A) 3 (B) 2 (C) 6 (D) 1
- Q.2** Let $f(x) = \sin^2\left(\frac{x}{2}\right) + \cos^2\left(\frac{x}{2}\right)$ and $g(x) = \sec^2 x - \tan^2 x$. The two functions are equal over the set -
 (A) ϕ
 (B) $R - \left\{x : x = (2n+1)\frac{\pi}{2}, n \in Z\right\}$
 (C) R
 (D) None of these
- Q.3** Domain and range of $\sin\left(\log\left(\frac{\sqrt{4-x^2}}{1-x}\right)\right)$ is
 (A) $[-2, 1), (-1, 1)$ (B) $(-2, 1), [-1, 1]$
 (C) $(-2, 1), R$ (D) None of these
- Q.4** The range of $\sin^{-1}\left[x^2 + \frac{1}{2}\right] + \cos^{-1}\left[x^2 - \frac{1}{2}\right]$ where $[]$ represent greatest integer function
 (A) $\left\{\frac{\pi}{2}, \pi\right\}$ (B) $\{\pi\}$
 (C) $\left\{\frac{\pi}{2}\right\}$ (D) None of these
- Q.5** Let $f(x) = \frac{9^x}{9^x + 3}$ and $f(x) + f(1-x) = 1$ then find value of $f\left(\frac{1}{1996}\right) + f\left(\frac{2}{1996}\right) + \dots + f\left(\frac{1995}{1996}\right)$ is -
 (A) 998 (B) 997
 (C) 997.5 (D) 998.5
- Q.6** If $f(x)$ be a polynomial satisfying $f(x) \cdot f\left(\frac{1}{x}\right) = f(x) + f\left(\frac{1}{x}\right)$ and $f(4) = 65$ then $f(6) = ?$
 (A) 176 (B) 217
 (C) 289 (D) None of these
- Q.7** Let $f: R \rightarrow R$ defined by $f(x) = \frac{\sin([x]\pi)}{x^2 + 2x + 4}$, where $[]$ represent greatest integer function, then which one is not true -
 (A) f is periodic (B) f is even
 (C) f is many-one (D) f is onto
- Q.8** Let $f: R \rightarrow R$ be a function defined by $f(x) = x + \sqrt{x^2}$, then f is -
 (A) Injective (B) Surjective
 (C) Bijective (D) None of these
- Q.9** Which of the following functions are equal?
 (A) $f(x) = x, g(x) = \sqrt{x^2}$
 (B) $f(x) = \log x^2, g(x) = 2 \log x$
 (C) $f(x) = 1, g(x) = \sin^2 x + \cos^2 x$
 (D) $f(x) = \frac{x}{x}, g(x) = 1$
- Q.10** Let $f: (4, 6) \rightarrow (6, 8)$ be a function defined by $f(x) = x + \left[\frac{x}{2}\right]$, where $[]$ represent greatest integer function then $f^{-1}(i)$ is equal to -
 (A) $x - 2$ (B) $x - \left[\frac{x}{2}\right]$
 (C) $-x - 2$ (D) None of these
- Q.11** The interval for which $\sin^{-1}\sqrt{x} + \cos^{-1}\sqrt{x} = \frac{\pi}{2}$ holds -
 (A) $[0, \infty)$ (B) $[0, 3]$
 (C) $[0, 1]$ (D) $[0, 2]$
- Q.12** The function $f(x) = \sqrt{\log_{10} \cos(2\pi x)}$ exists -
 (A) for any rational x
 (B) only when x is a positive integer
 (C) only when x is fractional
 (D) for any integer value of x including zero
- Q.13** The domain of the function $\sec^{-1}[x^2 - x + 1]$, is given by (where $[]$ is greatest integer function)-
 (A) $[0, 1]$ (B) $(-\infty, 0] \cup [1, \infty)$
 (C) $\left[\frac{1-\sqrt{5}}{2}, \frac{1+\sqrt{5}}{2}\right]$ (D) None of these
- Q.14** The domain of definition of the function $f(x) = \frac{\cot^{-1} x}{\sqrt{\{x^2 - [x^2]\}}}$, where $[x]$ denotes the greatest integer less than or equal to x is -
 (A) R
 (B) $R - \{\pm \sqrt{n} : n \in I^+ \cup \{0\}\}$
 (C) $R - \{0\}$
 (D) $R - \{n : n \in I\}$
- Q.15** The domain of the definition of $f(x) = \log\{(\log x)^2 - 5 \log x + 6\}$ is equal to -
 (A) $(0, 10^2)$ (B) $(10^3, \infty)$
 (C) $(10^2, 10^3)$ (D) $(0, 10^2) \cup (10^3, \infty)$

- Q.16** If $A = \left\{ x : \frac{\pi}{6} \leq x \leq \frac{\pi}{3} \right\}$ and $f(x) = \cos x - x(1+x)$ then $f(A)$ is equal to-
- (A) $\left[\frac{\pi}{6}, \frac{\pi}{3} \right]$
 (B) $\left[-\frac{\pi}{3}, -\frac{\pi}{6} \right]$
 (C) $\left[\frac{1}{2} - \frac{\pi}{3} \left(1 + \frac{\pi}{3} \right), \frac{\sqrt{3}}{2} - \frac{\pi}{6} \left(1 + \frac{\pi}{6} \right) \right]$
 (D) $\left[\frac{1}{2} + \frac{\pi}{3} \left(1 - \frac{\pi}{3} \right), \frac{\sqrt{3}}{2} + \frac{\pi}{6} \left(1 - \frac{\pi}{6} \right) \right]$
- Q.17** If A be the set of all triangles and B that of positive real numbers, then the mapping $f: A \rightarrow B$ given by $f(\Delta) = \text{area of } \Delta, (\Delta \in A)$ is
- (A) one-one into mapping
 (B) one-one onto mapping
 (C) many-one into mapping
 (D) many-one onto mapping
- Q.18** Let $f: R \rightarrow A = \left\{ y \mid 0 \leq y < \frac{\pi}{2} \right\}$ be a function such that $f(x) = \tan^{-1}(x^2 + x + k)$, where k is a constant. The value of k for which f is an onto function, is -
- (A) 1 (B) 0 (C) $\frac{1}{4}$ (D) None
- Q.19** Which of the following functions are not injective mapping-
- (A) $f(x) = |x+1|, x \in [-1, \infty)$
 (B) $g(x) = x + \frac{1}{x}; x \in (0, \infty)$
 (C) $h(x) = x^2 + 4x - 5; x \in (0, \infty)$
 (D) $k(x) = e^{-x}; x \in [0, \infty)$
- Q.20** Let f be an injective map. with domain $\{x, y, z\}$ and range $\{1, 2, 3\}$, such that exactly one of the following statements is correct and the remaining are false : $f(x) = 1, f(y) \neq 1, f(z) \neq 2$. The value of $f^{-1}(1)$ is -
- (A) x (B) y (C) z (D) None
- Q.21** Let $f: R \rightarrow R$ and $g: R \rightarrow R$ be two one-one onto functions such that they are mirror image of each other about the line $y = 0$, then $h(x) = f(x) + g(x)$ is-
- (A) One-one and onto
 (B) One-one but not onto
 (C) Not one-one but onto
 (D) Neither one-one nor onto
- Q.22** Fundamental period of $f(x) = e^{\cos(x)} + \sin \pi[x]$ is (where $[.]$ and $\{ \}$ denote the greatest integer function and fractional part of function respectively).
- (A) 1 (B) 2 (C) π (D) 2π

- Q.23** If $f(x) = \cos(ax) + \sin(bx)$ is periodic, then which of the followings is false -
- (A) a and b both are rational
 (B) non-periodic if a is rational but b is irrational
 (C) non-periodic if a is irrational but b is rational
 (D) None of these
- Q.24** If $f: [-20, 20] \rightarrow R$ is defined by $f(x) = \left[\frac{x^2}{a} \right] \sin x + \cos x$, is an even function, then the set of values of a is (Where $[.]$ denotes greatest integer function)-
- (A) $(-\infty, 100)$ (B) $(400, \infty)$
 (C) $(-400, 400)$ (D) None of these
- Q.25** Let f be a function satisfying $f(x+y) = f(x) \cdot f(y)$ for all $x, y \in R$. If $f(1) = 3$ then $\sum_{r=1}^n f(r)$ is equal to-
- (A) $\frac{3}{2}(3^n - 1)$ (B) $\frac{3}{2}n(n+1)$
 (C) $3^{n+1} - 3$ (D) None of these
- Q.26** If $f(x) = [x^2] - [x]^2$ where $[.]$ denotes the greatest integer function and $x \in [0, 2]$, the set of values of $f(x)$ is -
- (A) $\{-1, 0\}$ (B) $\{-1, 0, 1\}$ (C) $\{0\}$ (D) $\{0, 1, 2\}$
- Q.27** Domain of definition of the function $f(x) = \frac{3}{4-x^2} + \log_{10}(x^3 - x)$, is-
- (A) $(-1, 0) \cup (1, 2) \cup (2, \infty)$ (B) $(1, 2)$
 (C) $(-1, 0) \cup (1, 2)$ (D) $(1, 2) \cup (2, \infty)$
- Q.28** If $f: R \rightarrow R$ satisfies $f(x+y) = f(x) + f(y)$, for all $x, y \in R$ and $f(1) = 7$, then $\sum_{r=1}^n f(r)$ is-
- (A) $\frac{7n(n+1)}{2}$ (B) $\frac{7n}{2}$
 (C) $\frac{7(n+1)}{2}$ (D) $7n(n+1)$
- Q.29** Which of the following functions is inverse of itself -
- (A) $f(x) = \frac{1-x}{1+x}$ (B) $g(x) = 5^{\log x}$
 (C) $h(x) = 2^{x(x-1)}$ (D) None of these
- Q.30** If $f(\theta) = \frac{(2 \cos \theta - 1)(2 \cos 2\theta - 1)(2 \cos 4\theta - 1) \dots (2 \cos 2^{n-1}\theta - 1)}{2 \cos 2^n \theta + 1}$ for $n \in N$ and $\theta \neq 2m\pi \pm \frac{2\pi}{3}, m \in I$, then $f\left(\frac{\pi}{4}\right) =$
- (A) $1 - \sqrt{2}$ (B) $\sqrt{2} - 1$
 (C) $\sqrt{2} + 1$ (D) None of the

EXERCISE (Level-3)

Old Examination Questions [JEE Main]

Q.1 Let $f : (-1, 1) \rightarrow \mathbb{B}$, be a function defined by $f(x) = \tan^{-1} \frac{2x}{1-x^2}$, then f is both one-one and onto when \mathbb{B} is the interval [AIEEE-2005]

- (A) $\left(0, \frac{\pi}{2}\right)$ (B) $\left[0, \frac{\pi}{2}\right)$
 (C) $\left[-\frac{\pi}{2}, \frac{\pi}{2}\right)$ (D) $\left(-\frac{\pi}{2}, \frac{\pi}{2}\right)$

Q.2 A real valued function $f(x)$ satisfies the functional equation $f(x-y) = f(x)f(y) - f(a-x)f(a+y)$ where a is a given constant and $f(0) = 1$, then $f(2a-x)$ is equal to - [AIEEE-2005]

- (A) $-f(x)$ (B) $f(x)$
 (C) $f(a) + f(a-x)$ (D) $f(-x)$

Q.3 The largest interval lying in $\left(-\frac{\pi}{2}, \frac{\pi}{2}\right)$ for which the function

$f(x) = 4^{-x^2} + \cos^{-1}\left(\frac{x}{2} - 1\right) + \log(\cos x)$ defined, is - [AIEEE 2007]

- (A) $[0, \pi]$ (B) $\left(-\frac{\pi}{2}, \frac{\pi}{2}\right)$
 (C) $\left[-\frac{\pi}{4}, \frac{\pi}{2}\right)$ (D) $\left[0, \frac{\pi}{2}\right)$

Q.4 Let $f : \mathbb{N} \rightarrow \mathbb{Y}$ be a function defined as $f(x) = 4x + 3$ where $\mathbb{Y} = \{y \in \mathbb{N} : y = 4x + 3 \text{ for some } x \in \mathbb{N}\}$. Inverse of f is - [AIEEE 2008]

- (A) $g(y) = 4 + \frac{y+3}{4}$ (B) $g(y) = \frac{y+3}{4}$
 (C) $g(y) = \frac{y-3}{4}$ (D) $g(y) = \frac{3y+4}{3}$

Q.5 For real x , let $f(x) = x^3 + 5x + 1$, then - [AIEEE 2009]

- (A) f is one - one but not onto on \mathbb{R}
 (B) f is onto on \mathbb{R} but not one - one
 (C) f is one - one and onto on \mathbb{R}
 (D) f is neither one - one nor onto on \mathbb{R}

Q.6 Let $f(x) = (x+1)^2 - 1, x \geq -1$
Statement - 1 :
 The set $\{x : f(x) = f^{-1}(x)\} = \{0, -1\}$.

Statement - 2 :
 f is a bijection. [AIEEE 2009]

- (A) Statement -1 is true, Statement-2 is true; Statement-2 is a correct explanation for Statement -1
 (B) Statement-1 is true, Statement-2 is true; Statement-2 is **not** a correct explanation for Statement -1.
 (C) Statement -1 is true, Statement-2 is false.
 (D) Statement -1 is false, Statement-2 is true

Q.7 The domain of the function

$f(x) = \frac{1}{\sqrt{|x|-x}}$ is : [AIEEE 2011]

- (A) $(-\infty, \infty)$ (B) $(0, \infty)$
 (C) $(-\infty, 0)$ (D) $(-\infty, \infty) - \{0\}$

Q.8 Let A and B be nonempty set in \mathbb{R} and $f : A \rightarrow B$ be a bijective function.

Statement-1: f is an onto function

Statement-2 : There exists a function

$g : B \rightarrow A$ such that $f \circ g = I_B$.

[AIEEE Online- 2012]

- (A) Statement-1 is true, Statement-2 is true and Statement-2 is the correct explanation of Statement-1
 (B) Statement-1 is true, Statement-2 is true and Statement-2 is not the correct explanation of statement-1
 (C) Statement-1 is true, Statement-2 is false
 (D) Statement-1 is false, Statement-2 is true

Q.9 The range of the function $f(x) = \frac{x}{1+|x|}, x \in \mathbb{R}$ is :

[AIEEE Online- 2012]

- (A) $[-1, 1]$ (B) \mathbb{R} (C) $\mathbb{R} - \{0\}$ (D) $(-1, 1)$

Q.10 If $P(S)$ denotes the set of all subsets of a given set S , then the number of one to one functions from the set $S = \{1, 2, 3\}$ to the set $P(S)$ is :

[AIEEE Online- 2012]

- (A) 24 (B) 8 (C) 336 (D) 320

Q.11 Let $A = \{1, 2, 3, 4\}$ and $R : A \rightarrow A$ be the relation defined by $R = \{(1, 1), (2, 3), (3, 4), (4, 2)\}$. The correct statements is : [JEE Main Online -2013]

- (A) R does not have an inverse
 (B) R is not a one to one function
 (C) R is an onto function
 (D) R is not a function

Q.12 If $a \in \mathbb{R}$ and the equation $-3(x-[x])^2 + 2(x-[x]) + a^2 = 0$ (where $[x]$ denotes the greatest integer $\leq x$) has no integral solution, then all possible values of a lie in the interval : [JEE Main -2014]

- (A) $(-\infty, -2) \cup (2, \infty)$ (B) $(-1, 0) \cup (0, 1)$
 (C) $(1, 2)$ (D) $(-2, -1)$

Q.13 If $f(x) = \left(\frac{3}{5}\right)^x + \left(\frac{4}{5}\right)^x - 1$, $x \in \mathbb{R}$, then the equation $f(x) = 0$ has :

[JEE Main Online -2014]

- (A) no solution
 (B) one solution
 (C) two solution
 (D) more than two solutions

Q.14 Let f be an odd function defined on the set of real numbers such that for $x \geq 0$, $f(x) = 3 \sin x + 4 \cos x$. Then $f(x)$ at $x = -\frac{11\pi}{6}$ is equal to :

[JEE Main Online -2014]

- (A) $\frac{3}{2} + 2\sqrt{3}$ (B) $-\frac{3}{2} + 2\sqrt{3}$
 (C) $\frac{3}{2} - 2\sqrt{3}$ (D) $-\frac{3}{2} - 2\sqrt{3}$

Q.15 Let $f: \mathbb{R} \rightarrow \mathbb{R}$ be defined by $f(x) = \frac{|x| - 1}{|x| + 1}$ then f is

[JEE Main Online -2014]

- (A) Both one – one and onto
 (B) One – one but not onto
 (C) Onto but not one – one
 (D) Neither one – one nor onto

Q.16 Let $f(n) = \left[\frac{1}{3} + \frac{3n}{100}\right]n$, where $[n]$ denotes the greatest integer less than or equal to n . Then $\sum_{n=1}^{56} f(n)$ is equal to:

[JEE Main Online -2014]

- (A) 56 (B) 689 (C) 1287 (D) 1399

Q.17 The function $f(x) = |\sin 4x| + |\cos 2x|$, is a periodic function with period.

[JEE Main Online -2014]

- (A) 2π (B) π (C) $\frac{\pi}{2}$ (D) $\frac{\pi}{4}$

Q.18 If $f(x) + 2f\left(\frac{1}{x}\right) = 3x$, $x \neq 0$, and $S = \{x \in \mathbb{R} : f(x) = f(-x)\}$; then S :

[JEE Main - 2016]

- (A) is an empty set
 (B) contains exactly one element
 (C) contains exactly two elements
 (D) contains more than two elements

Q.19 For $x \in \mathbb{R}$, $x \neq 0$, $x \neq 1$, let $f_0(x) = \frac{1}{1-x}$ and $f_{n+1}(x) = f_0(f_n(x))$, $n = 0, 1, 2, \dots$. Then the value of $f_{100}(3) + f_1\left(\frac{2}{3}\right) + f_2\left(\frac{3}{2}\right)$ is equal to -

[JEE Main Online -2016]

- (A) $\frac{8}{3}$ (B) $\frac{5}{3}$ (C) $\frac{4}{3}$ (D) $\frac{1}{3}$

Q.20 The function $f: \mathbb{R} \rightarrow \left[-\frac{1}{2}, \frac{1}{2}\right]$ defined as

$f(x) = \frac{x}{1+x^2}$, is [JEE Main - 2017]

- (A) injective but not surjective
 (B) surjective but not injective
 (C) neither injective nor surjective
 (D) invertible

Q.21 Let $f(x) = 2^{10}x + 1$ and $g(x) = 3^{10}x - 1$. If $(f \circ g)(x) = x$, then x is equal to-

[JEE Main Online -2017]

- (A) $\frac{2^{10} - 1}{2^{10} - 3^{-10}}$ (B) $\frac{1 - 2^{-10}}{3^{10} - 2^{-10}}$
 (C) $\frac{3^{10} - 1}{2^{10} - 3^{-10}}$ (D) $\frac{1 - 3^{-10}}{2^{10} - 3^{-10}}$

Q.22 The function $f: \mathbb{N} \rightarrow \mathbb{N}$ defined by

$f(x) = x - 5\left[\frac{x}{5}\right]$, where \mathbb{N} is the set of natural numbers and $[x]$ denotes the greatest integer less than or equal to x , is -

[JEE Main Online -2017]

- (A) one-one but not onto
 (B) one-one and onto
 (C) neither one-one nor onto
 (D) onto but not one-one

Q.23 Let $f: A \rightarrow B$ be a function defined as

$f(x) = \frac{x-1}{x-2}$, where $A = \mathbb{R} - \{2\}$ and $B = \mathbb{R} - \{1\}$. Then f is -

[JEE-Main Online-2018]

- (A) invertible and $f^{-1}(y) = \frac{2y+1}{y-1}$
 (B) invertible and $f^{-1}(y) = \frac{3y-1}{y-1}$
 (C) no invertible
 (D) invertible and $f^{-1}(y) = \frac{2y-1}{y-1}$

Q.24 For $x \in \mathbb{R} - \{0, 1\}$, let $f_1(x) = \frac{1}{x}$, $f_2(x) = 1 - x$ and

$f_3(x) = \frac{1}{1-x}$ be three given functions. If a function, $J(x)$ satisfies $(f_2 \circ J \circ f_1)(x) = f_3(x)$ then $J(x)$ is equal to :

[JEE Main - 2019]

- (A) $\frac{1}{x} f_3(x)$ (B) $f_2(x)$
 (C) $f_3(x)$ (D) $f_1(x)$

- Q.25** Let $A = \{x \in \mathbb{R} : x \text{ is not a positive integer}\}$. Define a function $f : A \rightarrow \mathbb{R}$ as $f(x) = \frac{2x}{x-1}$, then f is : **[JEE Main - 2019]**
 (A) not injective
 (B) surjective but not injective
 (C) injective but not surjective
 (D) neither injective nor surjective
- Q.26** Let N be the set of natural numbers and two functions f and g be defined as $f, g : N \rightarrow N$ such that **[JEE Main - 2019]**

$$f(n) = \begin{cases} \frac{n+1}{2} & ; \text{ if } n \text{ is odd} \\ \frac{n}{2} & ; \text{ if } n \text{ is even} \end{cases} ; \text{ and}$$
 $g(n) = n - (-1)^n$. Then $f \circ g$ is
 (A) neither one-one nor onto
 (B) onto but not one-one
 (C) both one-one and onto
 (D) one-one but not onto
- Q.27** Let $f : \mathbb{R} \rightarrow \mathbb{R}$ be defined by $f(x) = \frac{x}{1+x^2}$, $x \in \mathbb{R}$. Then the range of f is **[JEE Main - 2019]**
 (A) $\left[-\frac{1}{2}, \frac{1}{2}\right]$ (B) $\mathbb{R} - \left[-\frac{1}{2}, \frac{1}{2}\right]$
 (C) $(-1, 1) - \{0\}$ (D) $\mathbb{R} - [-1, 1]$
- Q.28** Let $f_k(x) = \frac{1}{k}(\sin^k x + \cos^k x)$ for $k = 1, 2, 3, \dots$. Then for all $x \in \mathbb{R}$, the value of $f_4(x) - f_6(x)$ is equal to **[JEE Main - 2019]**
 (A) $\frac{1}{4}$ (B) $\frac{5}{12}$ (C) $-\frac{1}{12}$ (D) $\frac{1}{12}$
- Q.29** Let a function $f : (0, \infty) \rightarrow (0, \infty)$ be defined by $f(x) = \left|1 - \frac{1}{x}\right|$. Then f is : **[JEE Main - 2019]**
 (A) not injective but it is surjective
 (B) neither injective nor surjective
 (C) injective only
 (D) both injective as well as surjective
- Q.30** If $f(x) = \log_e \left(\frac{1-x}{1+x}\right)$, $|x| < 1$, then $f\left(\frac{2x}{1+x^2}\right)$ is equal to - **[JEE Main - 2019]**
 (A) $2f(x)$ (B) $2f(x^2)$
 (C) $(f(x))^2$ (D) $-2f(x)$
- Q.31** Let $f(x) = a^x$ ($a > 0$) be written as $f(x) = f_1(x) + f_2(x)$, where $f_1(x)$ is an even function and $f_2(x)$ is an odd function. Then $f_1(x+y) + f_1(x-y)$ equals **[JEE Main - 2019]**
 (A) $2f_1(x+y)f_2(x-y)$ (B) $2f_1(x+y)f_1(x-y)$
 (C) $2f_1(x)f_2(y)$ (D) $2f_1(x)f_1(y)$
- Q.32** Let $\sum_{k=1}^{10} f(a+k) = 16(2^{10} - 1)$, where the function f satisfies $f(x+y) = f(x)f(y)$ for all natural numbers x, y and $f(1) = 2$. Then the natural number 'a' is : **[JEE Main - 2019]**
 (A) 2 (B) 3 (C) 16 (D) 4
- Q.33** If the function $f : \mathbb{R} - \{1, -1\} \rightarrow A$ defined by $f(x) = \frac{x^2}{1-x^2}$, is surjective, then A is equal to : **[JEE Main - 2019]**
 (A) $\mathbb{R} - \{-1\}$ (B) $\mathbb{R} - [-1, 0)$
 (C) $\mathbb{R} - (-1, 0)$ (D) $[0, \infty)$
- Q.34** The domain of the definition of the function $f(x) = \frac{1}{4-x^2} + \log_{10}(x^3 - x)$ is : **[JEE Main - 2019]**
 (A) $(1, 2) \cup (2, \infty)$
 (B) $(-2, -1) \cup (-1, 0) \cup (2, \infty)$
 (C) $(-1, 0) \cup (1, 2) \cup (2, \infty)$
 (D) $(-1, 0) \cup (1, 2) \cup (3, \infty)$
- Q.35** Let $f(x) = x^2$, $x \in \mathbb{R}$. For any $A \subseteq \mathbb{R}$, define $g(A) = \{x \in \mathbb{R} : f(x) \in A\}$. If $S = [0, 4]$, then which one of the following statements is not true? **[JEE Main - 2019]**
 (A) $g(f(S)) \neq S$ (B) $f(g(S)) = S$
 (C) $f(g(S)) \neq f(S)$ (D) $g(f(S)) = g(S)$
- Q.36** For $x \in (0, 3/2)$, let $f(x) = \sqrt{x}$, $g(x) = \tan x$ and $h(x) = \frac{1-x^2}{1+x^2}$. If $\phi(x) = (h \circ f \circ g)(x)$, then $\phi\left(\frac{\pi}{3}\right)$ is equal to : **[JEE Main - 2019]**
 (A) $\tan \frac{7\pi}{12}$ (B) $\tan \frac{11\pi}{12}$
 (C) $\tan \frac{\pi}{12}$ (D) $\tan \frac{5\pi}{12}$
- Q.37** If $g(x) = x^2 + x - 1$ and $(g \circ f)(x) = 4x^2 - 10x + 5$, then $f\left(\frac{5}{4}\right)$ is equal to : **[JEE Main - 2020]**
 (A) $-\frac{3}{2}$ (B) $-\frac{1}{2}$ (C) $\frac{3}{2}$ (D) $\frac{1}{2}$
- Q.38** Let $f : \mathbb{R} \rightarrow \mathbb{R}$ be a function which satisfies $f(x+y) = f(x) + f(y) \forall x, y \in \mathbb{R}$. If $f(1) = 2$ and $g(n) = \sum_{k=1}^{(n-1)} f(k)$, $n \in \mathbb{N}$ then the value of n , for which $g(n) = 20$, is : **[JEE Main - 2020]**
 (A) 5 (B) 9 (C) 20 (D) 4

Q.39 Let $f : \mathbb{R} \rightarrow \mathbb{R}$ be defined as $f(x) = 2x - 1$ and $g : \mathbb{R} - \{1\} \rightarrow \mathbb{R}$ be defined as $g(x) = \frac{x-1}{x-1}$. Then the composition function $f(g(x))$ is :
[JEE Main - 2021]

- (1) onto but not one-one
- (2) both one-one and onto
- (3) one-one but not onto
- (4) neither one-one nor onto

Q.40 Let $A = \{2, 3, 4, 5, \dots, 30\}$ and ' \simeq ' be an equivalence relation on $A \times A$, defined by $(a, b) \simeq (c, d)$, if and only if $ad = bc$. Then the number of ordered pairs which satisfy this equivalence relation with ordered pair $(4, 3)$ is equal to :
[JEE Main - 2021]

- (1) 5
- (2) 6
- (3) 8
- (4) 7

Q.41 Let $f : \mathbb{R} - \{3\} \rightarrow \mathbb{R} - \{1\}$ be defined by $f(x) = \frac{x-2}{x-3}$. Let $g : \mathbb{R} \rightarrow \mathbb{R}$ be given as $g(x) = 2x - 3$. Then, the sum of all the values of x for which $f^{-1}(x) + g^{-1}(x) = \frac{13}{2}$ is equal to
[JEE Main - 2021]

- (1) 7
- (2) 2
- (3) 5
- (4) 3

Q.42 Let $f : \mathbb{N} \rightarrow \mathbb{R}$ be a function such that $f(x + y) = 2f(x)f(y)$ for natural numbers x and y . If $f(A) = 2$, then the value of α for which $\sum_{k=1}^{10} f(\alpha + k) = \frac{512}{3}(2^{20} - 1)$ holds, is :
[JEE Main-2022]

- (A) 2
- (B) 3
- (C) 4
- (D) 6

Q.43 Let $f(x) = \frac{x-1}{x+1}$, $x \in \mathbb{R} - \{0, -1, 1\}$. If $f^{n+1}(x) = f(f^n(x))$ for all $n \in \mathbb{N}$, then $f^6(6) = f^7(7)$ is equal to
[JEE Main-2022]

- (A) $\frac{7}{6}$
- (B) $-\frac{3}{2}$
- (C) $\frac{7}{12}$
- (D) $-\frac{11}{12}$

Q.44 Let $f : \mathbb{R} \rightarrow \mathbb{R}$ be defined as $f(x) = x - 1$ and $g : \mathbb{R} - \{1, -1\} \rightarrow \mathbb{R}$ be defined as $g(x) = \frac{x^2}{x^2 - 1}$. Then the function $f \circ g$ is :
[JEE Main-2022]

- (A) One-one but not onto
- (B) Onto but not one-one
- (C) Both one-one and onto
- (D) Neither one-one nor onto

Q.45 Let a function $f : \mathbb{N} \rightarrow \mathbb{N}$ be defined by $f(n) = \begin{cases} 2n, & n = 2, 4, 6, 8, \dots \\ n-1, & n = 3, 7, 11, 15, \dots \\ \frac{n+1}{2}, & n = 1, 5, 9, 13, \dots \end{cases}$

then, f is **[JEE Main-2022]**
 (A) One-one but not onto
 (B) Onto but not one-one
 (C) Neither one-one nor onto
 (D) One-one and onto

Q.46 Let $f : \mathbb{R} \rightarrow \mathbb{R}$ be a continuous function such that $f(3x) - f(x) = x$. If $f(8) = 7$, then $f(14)$ is equal to
[JEE Main-2022]

- (A) 4
- (B) 10
- (C) 11
- (D) 16

Q.47 Let $f(x)$ and $g(x)$ be two real polynomials of degree 2 and 1 respectively. If $f(g(x)) = 8x^2 - 2x$ and $g(f(x)) = 4x^2 + 6x + 1$, then the value of $f(B) + g(B)$ is _____.
[JEE Main-2022]

Q.48 The number of functions f , from the set $A = \{x \in \mathbb{N} : x^2 - 10x + 9 \leq 0\}$ to the set $B = \{n^2 : n \in \mathbb{N}\}$ such that $f(x) \leq (x - 3)^2 + 1$, for every $x \in A$, is _____.
[JEE Main-2022]

Q.49 If $f(x) = \frac{2^{2x}}{2^{2x} + 2}$, $x \in \mathbb{R}$, then $f\left(\frac{1}{2023}\right) + f\left(\frac{2}{2023}\right) + \dots + f\left(\frac{2022}{2023}\right)$ is equal to
[JEE Main-2023]

- (A) 1010
- (B) 2011
- (C) 1011
- (D) 2010

Q.50 Let $f(x)$ be a function such that $f(x + y) = f(x) \cdot f(y)$ for all $x, y \in \mathbb{N}$. If $f(1) = 3$ and $\sum_{k=1}^n f(k) = 3279$, then the value of n is
[JEE Main-2023]

- (A) 8
- (B) 9
- (C) 6
- (D) 7

Q.51 Let f, g and h be the real valued functions defined of \mathbb{R} as

$$f(x) = \begin{cases} \frac{x}{|x|}, & x \neq 0 \\ 1, & x = 0 \end{cases}, \quad g(x) = \begin{cases} \frac{\sin(x+1)}{(x+1)}, & x \neq -1 \\ 1, & x = -1 \end{cases}$$

and $h(x) = 2[x] - f(x)$, where $[x]$ is the greatest integer $\leq x$.

Then the value of $\lim_{x \rightarrow 1} g(h(x - 1))$ is
[JEE Main-2023]

- (A) 1
- (B) -1
- (C) $\sin(1)$
- (D) 0

Q.52 Let $f : (0, 1) \rightarrow \mathbb{R}$ be a function defined by $f(x) = \frac{1}{1 - e^{-x}}$, and $g(x) = (f(-x) - f(x))$. Consider

two statements

(I) g is an increasing function in $(0, 1)$

(II) g is one-one in $(0, 1)$

Then, **[JEE Main-2023]**

(A) Only (I) is true

(B) Both (I) and (II) are true

(C) Only (II) is true

(D) Neither (I) nor (II) is true

Q.53 Let $f : \mathbb{R} - \{0, 1\} \rightarrow \mathbb{R}$ be a function such that

$$f(x) + f\left(\frac{1}{1-x}\right) = 1 + x. \text{ then } f(2) \text{ is equal to:}$$

[JEE Main-2023]

- (A) $\frac{9}{2}$ (B) $\frac{9}{4}$ (C) $\frac{7}{3}$ (D) $\frac{7}{4}$

Q.54 The function $f : \mathbb{N} - \{1\} \rightarrow \mathbb{N}$; defined by $f(n) =$ the highest prime factor of n , is:

[JEE Main-2024]

(A) Both one-one and onto

(B) Neither one-one nor onto

(C) One-one only

(D) Onto only

Q.55 Let $f : \mathbb{R} - \left\{-\frac{1}{2}\right\} \rightarrow \mathbb{R}$ and $g : \mathbb{R} - \left\{-\frac{5}{2}\right\} \rightarrow \mathbb{R}$ be

defined as $f(x) = \frac{2x+3}{2x+1}$ and $g(x) = \frac{|x|+1}{2x+5}$. Then,

the domain of the function $f \circ g$ is:

[JEE Main-2024]

(A) \mathbb{R} (B) $\mathbb{R} - \left\{-\frac{5}{2}\right\}$

(C) $\mathbb{R} - \left\{-\frac{7}{4}\right\}$ (D) $\mathbb{R} - \left\{-\frac{5}{2}, -\frac{7}{4}\right\}$

Q.56 If $f(x) = \begin{cases} 2+2x, & -1 \leq x < 0 \\ 1-\frac{x}{3}, & 0 \leq x \leq 3 \end{cases}$;

$$g(x) = \begin{cases} -x, & -3 \leq x \leq 0 \\ x, & 0 < x \leq 1 \end{cases},$$

then range of $(f \circ g)(x)$ is- **[JEE Main-2024]**

- (A) $[0, 1]$ (B) $(0, 1]$ (C) $[0, 1)$ (D) $[0, 3)$

Q.57 Let the sum of the maximum and the minimum values of the function $f(x) = \frac{2x^2 - 3x + 8}{2x^2 + 3x + 8}$ be

$\frac{m}{n}$ where $\gcd(m, n) = 1$. Then $m + n$ is equal to :

[JEE Main-2024]

- (A) 182 (B) 217 (C) 195 (D) 201

Q.58 Let $f(x) = 3\sqrt{x-2} + \sqrt{4-x}$ be a real valued function. If α and β are respectively the minimum and the maximum values of f , then $\alpha^2 + 2\beta^2$ is equal to **[JEE Main-2024]**

- (A) 44 (B) 42 (C) 24 (D) 38

EXERCISE (Level-4)

Part-A : Multiple correct answer type questions

Q.1 If $f(x) = \sqrt{x^2 - |x|}$, $g(x) = \frac{1}{\sqrt{9-x^2}}$ then D_{f+g}

contains

- (A) $(-3, -1)$ (B) $[1, 3)$
(C) $[-3, 3]$ (D) $\{0\} \cup [1, 3)$

Q.2 If $f(x) = \frac{3x-1}{3x^3+2x^2-x}$ and $S = \{x \mid f(x) > 0\}$

then S contains

- (A) $(-\infty, -2)$ (B) $(\frac{1}{3}, 5)$
(C) $(-\infty, -1)$ (D) $(0, \infty) - \{\frac{1}{3}\}$

Q.3 If D is the domain of the function

$$f(x) = \sqrt{1-2x} + 3 \sin^{-1}\left(\frac{3x-1}{2}\right) \text{ then D}$$

contains-

- (A) $[-\frac{1}{3}, \frac{1}{2}]$ (B) $[-\frac{1}{3}, 0]$
(C) $[-\frac{1}{3}, 1]$ (D) $[\frac{1}{2}, 1]$

Q.4 Let $A = R - \{2\}$ and $B = R - \{1\}$.

Let $f: A \rightarrow B$ be defined by $f(x) = \frac{x-3}{x-2}$ then-

- (A) f is one-one (B) f is onto
(C) f is bijective (D) None of these

Q.5 If $F(x) = \frac{\sin \pi[x]}{\{x\}}$, then $F(x)$ is:

- (A) Periodic with fundamental period 1
(B) Even
(C) Range is singleton
(D) Identical to $\operatorname{sgn}\left(\operatorname{sgn}\frac{\{x\}}{\sqrt{\{x\}}}\right) - 1$, where $\{x\}$ denotes fractional part function and $[.]$ denotes greatest integer function and $\operatorname{sgn}(x)$ is a signum function.

Q.6 Let $f: [-1, 1] \rightarrow [0, 2]$ be a linear function which is onto then $f(x)$ is/are

- (A) $1-x$ (B) $1+x$ (C) $x-1$ (D) $x+2$

Q.7 In the following functions defined from $[-1, 1]$ to $[-1, 1]$ the functions which are not bijective are:

- (A) $\sin(\sin^{-1}x)$ (B) $\frac{2}{\pi} \sin^{-1}(\sin x)$
(C) $(\operatorname{sgn} x) \ln e^x$ (D) $x^3 \operatorname{sgn} x$

Q.8 Which of the following function is periodic ?

- (A) $\operatorname{sgn}(e^{-x})$
(B) $\sin x + |\sin x|$
(C) $\min(\sin x, |x|)$
(D) $\left[x + \frac{1}{2}\right] + \left[x - \frac{1}{2}\right] + 2[-x]$

Where $[x]$ denotes greatest integer function.

Q.9 If $f(x) = \begin{cases} 2x+3 & x \leq 1 \\ a^2x+1 & x > 1 \end{cases}$ then values of 'a' for

which $f(x)$ is injective is

- (A) -3 (B) 3 (C) 0 (D) 1

Q.10 Consider the function $y = f(x)$ satisfying the

condition $f\left(x + \frac{1}{x}\right) = x^2 + \frac{1}{x^2}$ ($x \neq 0$), then

- (A) domain of $f(x)$ is R
(B) domain of $f(x)$ is $R - (-2, 2)$
(C) range of $f(x)$ is $[-2, \infty)$
(D) range of $f(x)$ is $[2, \infty)$

Q.11 Consider the real-valued function satisfying $2f(\sin x) + f(\cos x) = x$. Then

- (A) domain of $f(x)$ is R
(B) domain of $f(x)$ is $[-1, 1]$
(C) range of $f(x)$ is $\left[-\frac{2\pi}{3}, \frac{\pi}{3}\right]$
(D) range of $f(x)$ is R

Q.12 Let $f(x) = x^2 - 2ax + a(a+1)$, $f: [a, \infty) \rightarrow [a, \infty)$. If one of the solutions of the equation $f(x) = f^{-1}(x)$ is 5049, then the other may be

- (A) 5051 (B) 5048 (C) 5052 (D) 5050

Q.13 If $f: R^+ \rightarrow R^+$ is a polynomial function satisfying the functional equation

$f(f(x)) = 6x - f(x)$, then $f(17)$ is equal to -

- (A) 17 (B) -51 (C) 34 (D) -34

Q.14 $f: R \rightarrow [-1, \infty)$ and $f(x) = \ln(|\sin 2x| + |\cos 2x|)$

(where $[.]$ is the greatest integer function)

- (A) $f(x)$ has range Z
(B) $f(x)$ is periodic with fundamental period $\pi/4$
(C) $f(x)$ is invertible in $\left[0, \frac{\pi}{4}\right]$

(D) $f(x)$ is into function

Q.15 Let $f(x) = \operatorname{sgn}(\cot^{-1}x) + \tan\left(\frac{\pi}{2}[x]\right)$, where $[x]$ is

the greatest integer function less than or equal x . Then which of the following alternatives is/are true ?

- (A) $f(x)$ is many one but not even function
(B) $f(x)$ is periodic function
(C) $f(x)$ is bounded function
(D) Graph of $f(x)$ remains above the x -axis

- Q.16** Let $f: \mathbb{R} \rightarrow \mathbb{R}$ be defined by $f(x) = \max(1 + |x|, 2 - |x|)$ then which of the following holds(s) good ?
 (A) f is periodic function
 (B) f is neither injective nor surjective
 (C) f is even function
 (D) Range of $f = \left[\frac{3}{2}, \infty \right)$

- Q.17** Which of the following pair(s) of function have same graphs ?

(A) $f(x) = \frac{\sec x}{\cos x} - \frac{\tan x}{\cot x}$, $g(x) = \frac{\cos x}{\sec x} + \frac{\sin x}{\operatorname{cosec} x}$

(B) $f(x) = \operatorname{sgn}(x^2 - 4x + 5)$,

$g(x) = \operatorname{sgn} \left(\cos^2 x + \sin^2 \left(x + \frac{\pi}{3} \right) \right)$ where

sgn denotes signum function

(C) $f(x) = e^{\ln(x^2+3x+3)}$, $g(x) = x^2 + 3x + 3$

(D) $f(x) = \frac{\sin x}{\sec x} + \frac{\cos x}{\operatorname{cosec} x}$, $g(x) = \frac{2 \cos^2 x}{\cot x}$

- Q.18** Let f be a constant function with domain \mathbb{R} and g be a certain function with domain \mathbb{R} . Two ordered pairs in f are $(4, a^2 - 5)$ and $(2, 4a - 9)$ for some real number a . Also domain of $\frac{f}{g}$ is $\mathbb{R} - \{7\}$. Then

(A) $a = 2$ (B) $(f(10))^{100} = 1$

(C) $(100)^{g(7)} = 1$ (D) $\int_0^1 f(x) dx = 1$

Part-B : Assertion Reason type Questions

The following questions 19 to 22 consists of two statements each, printed as Assertion and Reason. While answering these questions you are to choose any one of the following four responses.

- (A) If both Assertion and Reason are true and the Reason is correct explanation of the Assertion.
 (B) If both Assertion and Reason are true but Reason is not correct explanation of the Assertion.
 (C) If Assertion is true but the Reason is false.
 (D) If Assertion is false but Reason is true

- Q.19** **Assertion :** Function $f(x) = \sin x + \{x\}$ is periodic with period 2π .

Reason : $\sin x$ and $\{x\}$ are both periodic functions with period 2π and 1 respectively.

- Q.20** **Assertion:** If $f(x)$ & $g(x)$ both are one-one, then $f(g(x))$ is also one-one.

Reason : If, $f(x_1) = f(x_2) \Leftrightarrow x_1 = x_2$ then $f(x)$ is one-one

- Q.21** **Assertion:** Let $f: [0, 3] \rightarrow [1, 13]$ is defined by $f(x) = x^2 + x + 1$ then inverse is

$$f^{-1}(x) = \frac{-1 + \sqrt{4x - 3}}{2}$$

Reason: Many-one function is not invertible

- Q.22** **Assertion:** Fundamental period of $\cos x + \cot x$ is 2π .

Reason: If the period of $f(x)$ is T_1 and the period of $g(x)$ is T_2 , then the fundamental period of $f(x) + g(x)$ is the L.C.M. of T_1 and T_2 .

Part-C : Column Matching type Questions

Match the entry in Column 1 with the entry in Column 2.

- Q.23** Match the following :

Column 1 **Column 2**

(A) Range of $\sqrt{[\sin 2x] - [\cos 2x]}$ (P) $\{1, 2, 3\}$

(B) Domain of $\sqrt{x^2+4x} C_{2x^2+3}$ (Q) $\{1\}$

(C) Range of $\sqrt{\log(\cos(\sin x))}$ (R) $\{0, 1\}$

(D) Range of $[|\sin x| + |\cos x|]$ (S) $\{0\}$
 (Where $[.]$ denotes greatest integer function)

- Q.24** Match the following :

Column 1 **Column 2**

(A) Period of $\frac{1}{2} \left\{ \frac{|\sin x|}{\cos x} + \frac{|\cos x|}{\sin x} \right\}$ (P) 2

(B) Range of $\cos^{-1} \sqrt{\log_{[x]} \frac{|x|}{x}}$ (Q) 2π

(C) Total number of solution of $x^2 - 4 - [x] = 0$ is (R) 1

(D) Fundamental period of $e^{\cos^4 \pi x + x - [x] + \cos^2 \pi x}$ (S) $\frac{\pi}{2}$

(Where $[.]$ denotes greatest integer function)

- Q.25** Match the following :

Column 1 **Column 2**

(A) Domain of $f(x) = \sqrt{2^x - 3^x} + \log_3 \log_{1/2} x$ is (P) $[0, 1]$

(B) Solution set of equation $2 \cos^2 \frac{x}{2} \sin^2 x = x^2 + \frac{1}{x^2}$ is (Q) $[0, \infty)$

(C) If $A = \left\{ (x, y); y = \frac{1}{x}, x \in \mathbb{R}_0 \right\}$ (R) $[1, \infty)$

& $B = \{(x, y); y = -x, x \in \mathbb{R}\}$
 then $A \cap B$ is

(D) The functions $f(x) = \sqrt{x} \sqrt{x-1}$ (S) ϕ

& $\phi(x) = \sqrt{x^2 - x}$ are identical in

Q.26 Match the following :

Column 1

Column 2

(A) The fundamental period of the function

(P) $\frac{1}{2}$

$$y = \sin\left(2\pi t + \frac{\pi}{3}\right) + 2 \sin\left(3\pi t + \frac{\pi}{4}\right) + 3 \sin 5\pi t$$

(B) $y = \{\sin(\pi x)\}$ is a many one function for $x \in (0, a)$ where $\{\}$ denotes fractional part of x and a may be (Q) 8

(C) The Fundamental period of the function (R) 2

$$y = \frac{1}{2} \left(\frac{|\sin(\pi/4)x| + \sin(\pi/4)x}{\cos(\pi/4)x} + \frac{\sin(\pi/4)x}{|\cos(\pi/4)x|} \right)$$

(D) If $f: [0, 2] \rightarrow [0, 2]$ is bijective function defined by $f(x) = ax^2 + bx + c$, where a, b, c are non-zero real numbers, then $f(2)$ is equal to (S) 0

Part-D : Passage based objective questions

Passage # 1 (Q.27 to 29)

Let $f(x) = x^2 - 3x + 2$, $g(x) = f(|x|)$
 $h(x) = |g(x)|$ and $I(x) = |g(x)| - [x]$
 are four function, where $[x]$ is the integral part of real x .

Q.27 Find the value of 'a' such that equation $g(x) - a = 0$ has exactly 3 real roots-
 (A) 2 (B) 1
 (C) 0 (D) None of these

Q.28 Find the set of values of 'b' such that equation $h(x) - b = 0$ has exactly 8 real solution
 (A) $b \in \left[0, \frac{1}{4}\right]$ (B) $b \in \left[0, \frac{1}{4}\right)$
 (C) $b \in \left(0, \frac{1}{4}\right)$ (D) None of these

Q.29 Which statement is true for $I(x) = 0$ -
 (A) Two values of x is satisfied for $I(x) = 0$
 (B) One value of x is satisfied for $I(x) = 0$ and that x lie between 1 and 2
 (C) One value of x is satisfied for $I(x) = 0$ and that x lie between 3 and 4
 (D) None of these

Passage # 2 (Q.30 to 32)

If $f(x) = 0$; if $x \in \mathbb{Q}$
 $= 1$; if $x \notin \mathbb{Q}$.
 then answer the following questions-

Q.30 $f(x)$ is -
 (A) an even function
 (B) an odd function
 (C) Neither even nor odd function
 (D) one-one function

Q.31 $f(f(x))$ is-
 (A) a constant function
 (B) an even function
 (C) an odd function
 (D) many one function

Q.32 Domain of $g(x) = \ln(\operatorname{sgn} f(x))$ is-
 (A) \mathbb{R}
 (B) set of all rational numbers
 (C) set of all irrational number
 (D) \mathbb{R}^+

Passage # 3 (Q.33 to 35)

Consider the function

$$f(x) = \begin{cases} x - [x] - \frac{1}{2}; & \text{if } x \notin \mathbb{I} \\ 0 & ; \text{if } x \in \mathbb{I} \end{cases}$$

where $[.]$ denotes greatest integer function.
 If $g(x) = \max.\{x^2, f(x), |x|\}$; $-2 \leq x \leq 2$, then

Q.33 Range of $f(x)$ is-

(A) $[0, 1)$ (B) $\left[-\frac{1}{2}, \frac{1}{2}\right]$
 (C) $\left(-\frac{1}{2}, \frac{1}{2}\right)$ (D) $\left[-\frac{1}{2}, \frac{1}{2}\right)$

Q.34 $f(x)$ is-
 (A) non periodic
 (B) periodic with fundamental period 1
 (C) periodic with fundamental period 2
 (D) periodic with fundamental period $\frac{1}{2}$

Q.35 The set of values of a , if $g(x) = a$ has three real and distinct solutions, is -
 (A) $\left(0, \frac{1}{2}\right)$ (B) $\left(0, \frac{1}{4}\right)$
 (C) $\left(\frac{1}{4}, \frac{1}{2}\right)$ (D) $(0, 1)$

Passage # 4 (Q.36 to 38)

Consider the function

$$f(x) = \begin{cases} x^2 - 1, & -1 \leq x \leq 1 \\ \ln x, & 1 < x \leq e \end{cases}$$

Let $f_1(x) = f(|x|)$
 $f_2(x) = |f(|x|)|$
 $f_3(x) = f(-x)$

Q.36 Number of positive solutions of the equation $2f_2(x) - 1 = 0$ is-
 (A) 4 (B) 3 (C) 2 (D) 1

Q.37 Number of integral solution of the equation $f_1(x) = f_2(x)$ is
 (A) 1 (B) 2 (C) 3 (D) 4

- Q.38** If $f_4(x) = \log_{27}(f_3(x) + 2)$, then range of $f_4(x)$ is
 (A) $[1, 9]$ (B) $\left[\frac{1}{3}, \infty\right)$ (C) $\left[0, \frac{1}{3}\right]$ (D) $[1, 27]$

Part-E : Numeric Response Type Questions

- Q.39** Let $f(x) = \left[\frac{1}{\cos\{x\}} \right]$ where $[y]$ and $\{y\}$ denote greatest integer and fractional part function respectively and $g(x) = 2x^2 - 3x(k+1) + k(3k+1)$. If $g(f(x)) < 0 \forall x \in \mathbb{R}$ then find the number of integral values of k .
- Q.40** If $x = \log_4 \left(\frac{2f(x)}{1-f(x)} \right)$, then find $(f(2010) + f(-2009))$.
- Q.41** If M and m are maximum and minimum value of $f(\theta) = 5 \sin^2 \theta - 8 \sin \theta + 4$, $\theta \in \left[\frac{\pi}{3}, \frac{5\pi}{6} \right]$, respectively then find the value of $(2Mm)$.
- Q.42** Let f be a function such that $4f(x^{-1} + 1) + 8f(x + 1) = \log_{12} x$, then find the value of $4(f(10) + f(13) + f(17))$.
- Q.43** Let f be a real valued invertible function such that $f\left(\frac{2x-3}{x-2}\right) = 5x-2$, $x \neq 2$. Find $f^{-1}(13)$.

Part-F : Subjective Type Questions

- Q.44** Find the domains of definitions of the following functions:
 (Read the symbols $[*]$ and $\{*\}$ as greatest integers and fractional part functions respectively)
- (i) $f(x) = \sqrt{\cos 2x} + \sqrt{16-x^2}$
 (ii) $f(x) = \log_7 \log_5 \log_3 \log_2 (2x^3 + 5x^2 - 14x)$
 (iii) $f(x) = \ln \left(\sqrt{x^2 - 5x - 24} - x - 2 \right)$
 (iv) $f(x) = \sqrt{\frac{1-5^x}{7^{-x}-7}}$
 (v) $y = \log_{10} \sin(x-3) + \sqrt{16-x^2}$
 (vi) $f(x) = \log_{100x} \left(\frac{2 \log_{10} x + 1}{-x} \right)$
 (vii) $f(x) = \frac{1}{\sqrt{4x^2-1}} + \ln x(x^2-1)$
 (viii) $f(x) = \sqrt{\log_{1/2} \frac{x}{x^2-1}}$
 (ix) $f(x) = \sqrt{x^2 - |x|} + \frac{1}{\sqrt{9-x^2}}$
 (x) $f(x) = \sqrt{\log_x(\cos 2\pi x)}$

$$\begin{aligned} \text{(xi)} \quad f(x) &= \frac{\sqrt{\cos x - (1/2)}}{\sqrt{6 + 35x - 6x^2}} \\ \text{(xii)} \quad f(x) &= \sqrt{\log_{1/3}(\log_4([x]^2 - 5))} \\ \text{(xiii)} \quad f(x) &= \frac{[x]}{2x - [x]} \\ \text{(xiv)} \quad f(x) &= \log_x \sin x \\ \text{(xv)} \quad f(x) &= \log_{\left[x + \frac{1}{x}\right]} |x^2 - x - 6| + \\ &\quad 16^{-x} C_{2x-1} + 20^{-3x} P_{2x-5} \end{aligned}$$

- Q.45** Find the domain and range of the following functions. (Read the symbols $[*]$ & $\{*\}$ as greatest integers & fractional part functions respectively)
- (i) $y = \log_{\sqrt{5}} (\sqrt{2}(\sin x - \cos x) + 3)$
 (ii) $y = \frac{2x}{1+x^2}$
 (iii) $f(x) = \frac{x^2 - 3x + 2}{x^2 + x - 6}$
 (iv) $f(x) = \frac{x}{1+|x|}$
 (v) $y = \sqrt{2-x} + \sqrt{1+x}$
 (vi) $f(x) = \log_{(\operatorname{cosec} x - 1)} (2 - [\sin x] - [\sin x]^2)$
 (vii) $f(x) = \frac{\sqrt{x+4} - 3}{x-5}$
 (viii) $\cot^{-1}(2x - x^2)$.
 (ix) $f(x) = \log_2 (\sqrt{x-4} + \sqrt{6-x})$
- Q.46** (a) Draw graphs of the following function, where $[]$ denotes the greatest integer function.
 (i) $f(x) = x + [x]$
 (ii) $y = (x)[x]$ where $x = [x] + \{x\}$ & $x > 0$ and $x \leq 3$
 (iii) $y = \operatorname{sgn} [x]$
 (iv) $\operatorname{sgn}(x - |x|)$
 (b) Identify the pair(s) of functions which are identical? (where $[x]$ denotes greatest integer and $\{x\}$ denotes fractional part function)
 (i) $f(x) = \operatorname{sgn}(x^2 - 3x + 4)$ and $g(x) = e^{[\operatorname{sgn} x]}$
 (ii) $f(x) = \sqrt{\frac{1 - \cos 2x}{1 + \cos 2x}}$ and $g(x) = \tan x$
 (iii) $f(x) = \ln(1+x) + \ln(1-x)$ and $g(x) = \ln(1-x^2)$
 (iv) $f(x) = \frac{\cos x}{1 - \sin x}$ & $g(x) = \frac{1 + \sin x}{\cos x}$
- Q.47** Let f be a function satisfying $2f(xy) = \{f(y)\}y + \{f(x)\}x$ and $f(1) = k \neq 1$.
 Prove that $(k-1) \sum_{n=1}^n F(n) = k^{n+1} - k$

Q.48 Determine all functions f satisfying the functional relation

$$f(x) + f\left(\frac{1}{1-x}\right) = \frac{2(1-2x)}{x(1-x)}$$

where x is a real number, $x \neq 0, x \neq 1$.

Q.49 Let $\{x\}$ and $[x]$ denotes the fractional and integral part of a real number x respectively. Solve $4\{x\} = x + [x]$.

Q.50 Let $f(x) = x^2 + kx$; k is a real number. The set of values of k for which the equation $f(x) = 0$ and $f(f(x)) = 0$ have same real solution set.

Q.51 Let $f(x)$ be defined on $[-2, 2]$ and is given by

$$f(x) = \begin{cases} -1 & -2 \leq x \leq 0 \\ x-1 & 0 < x \leq 2 \end{cases} \text{ and}$$

$g(x) = f(|x|) + |f(x)|$. Then find $g(x)$.

Q.52 Solve the equation:
 $|2x - 1| = 3[x] + 2\{x\}$ where $[\cdot]$ and $\{ \cdot \}$ denotes greatest integer function and fractional part function respectively.

Q.53 Let $f(x) = \begin{cases} 3^{x-1} + \frac{8}{3} & \text{for } 0 \leq x \leq 2 \\ 7 + \log_2(x-2) & \text{for } 2 < x \leq 4 \\ x^2 - 9x + 21 & \text{for } 4 < x \leq 6 \end{cases}$.

A set ' B ' is formed by elements which are ' f ' images of the elements of set A . If $B = \{1, 3, 5, 7\}$, find A . Hence or otherwise state reasons whether it is possible to have a function, $f^{-1} : B \rightarrow A$ or not?

Q.54 If $f(x) \in [1, 2]$ when $x \in R$ and for a fixed positive real number p ,

$$f(x+p) = 1 + \sqrt{2f(x) - \{f(x)\}^2} \text{ for all } x \in R$$

then prove that $f(x)$ is a periodic function.

Q.55 If $f(a-x) = f(a+x)$ and $f(b-x) = f(b+x)$ for all real x where a, b ($a > b$) are constants then prove that $f(x)$ is a periodic function.

Q.56 Let $f : R \rightarrow R$ be a function given by $f(x+y) + f(x-y) = 2f(x)f(y)$ for all $x, y \in R$ and $f(0) \neq 0$. Prove that $f(x)$ is an even function.

Q.57 Let $f : [-2, 2] \rightarrow R$ be a function if, for $x \in [0, 2]$

$$f(x) = \begin{cases} x \tan x, & 0 < x \leq \frac{\pi}{2} \\ \frac{\pi}{2}[x], & \frac{\pi}{2} < x \leq 2 \end{cases}$$

define f for $x \in [-2, 0]$ when

(i) f is odd function

(ii) f is an even function

(where $[\cdot]$ is the greatest integer function)

Q.58 If $f(x) = -1 + |x-2|$, $0 \leq x < 4$

$$g(x) = 2 - |x|, -1 \leq x \leq 3$$

Then find $f \circ g(x)$, $g \circ f(x)$ & $f \circ f(x)$ & $g \circ g(x)$. Draw rough sketch of the graphs of $f \circ g(x)$ & $g \circ f(x)$.

Q.59 If $f(x) = \ln(x^2 - x + 2)$; $R^+ \rightarrow R$ and

$$g(x) = \{x\} + 1; [1, 2] \rightarrow [1, 2],$$

where $\{x\}$ denotes fractional part of x find the domain and range of $f \circ g(x)$ when defined.

Q.60 Examine whether the following functions are even or odd or none.

(i) $f(x) = \frac{(1+2^x)^7}{2^x}$

(ii) $f(x) = \frac{\sec x + x^2 - 9}{x \sin x}$

(iii) $f(x) = \frac{x}{e^x - 1} + \frac{x}{2} + 1$

(iv) $f(x) = \begin{cases} x|x| & x \leq -1 \\ [1+x] + [1-x] & -1 < x < 1 \\ -x|x| & x \geq 1 \end{cases}$

(v) $f(x) = \frac{2x(\sin x + \tan x)}{2\left[\frac{x+2\pi}{\pi}\right] - 3}$

where $[\cdot]$ denotes greatest integer function.

Q.61 Find the period of the following functions.

(i) $f(x) = 1 - \frac{\sin^2 x}{1 + \cot x} - \frac{\cos^2 x}{1 + \tan x}$

(ii) $f(x) = \tan \frac{\pi}{2}[x]$ where $[\cdot]$ denotes greatest integer function.

(iii) $f(x) = \log(2 + \cos 3x)$

(iv) $f(x) = e^{\ln \sin x} + \tan^3 x - \operatorname{cosec}(3x - 5)$

(v) $f(x) = \sin x + \tan \frac{x}{2} + \sin \frac{x}{2} + \tan \frac{x}{2^2}$

$$+ \sin \frac{x}{2^2} + \tan \frac{x}{2^3} \dots + \sin \frac{x}{2^{n-1}} + \tan \frac{x}{2^n}$$

(vi) $f(x) = \frac{\sin x + \sin 3x}{\cos x + \cos 3x}$

Q.62 A function f , defined for all $x, y \in R$ is such that $f(1) = 2$; $f(2) = 8$ and $f(x+y) - kxy = f(x) + 2y^2$, where k is some constant. Find $f(x)$ & show that

$$f(x+y)f\left(\frac{1}{x+y}\right) = k \text{ for } x+y \neq 0.$$

Q.63 Suppose $p(x)$ is a polynomial with integer coefficients. The remainder when $p(x)$ is divided by $x-1$ is 1 and the remainder when $p(x)$ is divided by $x-4$ is 10. If $r(x)$ is the remainder when $p(x)$ is divided by $(x-1)(x-4)$, find the value of $r(2006)$.

EXERCISE (Level-5)

Old Examination Questions [JEE Advanced]

Q.1 $f(x) = \begin{cases} x, & x \in \mathbb{Q} \\ 0, & x \notin \mathbb{Q} \end{cases}$; $g(x) = \begin{cases} 0 & x \in \mathbb{Q} \\ x & x \notin \mathbb{Q} \end{cases}$
then $(f - g)$ is [IIT Scr. 2005]

- (A) one-one, onto
- (B) neither one-one, nor onto
- (C) one-one but not onto
- (D) onto but not one-one

Q.2 If X and Y are two non-empty sets where $f: X \rightarrow Y$ is function is defined such that $f(C) = \{f(x): x \in C\}$ for $C \subseteq X$ and $f^{-1}(D) = \{x: f(x) \in D\}$ for $D \subseteq Y$ for any $A \subseteq X$ and $B \subseteq Y$ then- [IIT 2005]

- (A) $f^{-1}(f(A)) = A$
- (B) $f^{-1}(f(A)) = A$ only if $f(X) = Y$
- (C) $f(f^{-1}(B)) = B$ only if $B \subseteq f(X)$
- (D) $f(f^{-1}(B)) = B$

Q.3 Find the range of values of t for which $2 \sin t = \frac{1 - 2x + 5x^2}{3x^2 - 2x - 1}$; $t \in \left[-\frac{\pi}{2}, \frac{\pi}{2}\right]$ [IIT 2005]

Q.4 Let $f(x) = \frac{x^2 - 6x + 5}{x^2 - 5x + 6}$ [IIT 2007].

- | Column-I | Column-II |
|---|--------------------|
| (A) If $-1 < x < 1$, then $f(x)$ satisfies | (P) $0 < f(x) < 1$ |
| (B) If $1 < x < 2$, then $f(x)$ satisfies | (Q) $f(x) < 0$ |
| (C) If $3 < x < 5$, then $f(x)$ satisfies | (R) $f(x) > 0$ |
| (D) If $x > 5$, then $f(x)$ satisfies | (S) $f(x) < 1$ |

Q.5 Let $f(x) = x^2$ and $g(x) = \sin x$ for all $x \in \mathbb{R}$. Then the set of all x satisfying $(f \circ g \circ g \circ f)(x) = (g \circ g \circ f)(x)$, where $(f \circ g)(x) = f(g(x))$, is [IIT 2011]

- (A) $\pm \sqrt{n\pi}$, $n \in \{0, 1, 2, \dots\}$
- (B) $\pm \sqrt{n\pi}$, $n \in \{1, 2, \dots\}$
- (C) $\frac{\pi}{2} + 2n\pi$, $n \in \{\dots, -2, -1, 0, 1, 2, \dots\}$
- (D) $2n\pi$, $n \in \{\dots, -2, -1, 0, 1, 2, \dots\}$

Q.6 The function $f: [0, 3] \rightarrow [1, 29]$, defined by $f(x) = 2x^3 - 15x^2 + 36x + 1$, is [IIT 2012]

- (A) one-one and onto.
- (B) onto but not one-one.
- (C) one-one but not onto.
- (D) neither one-one nor onto.

Q.7 Let $f: (-1, 1) \rightarrow \mathbb{R}$ be such that $f(\cos 4\theta) = \frac{2}{2 - \sec^2 \theta}$ for $\theta \in \left(0, \frac{\pi}{4}\right) \cup \left(\frac{\pi}{4}, \frac{\pi}{2}\right)$.

Then the value(s) of $f\left(\frac{1}{3}\right)$ is (are)

MCQ [IIT 2012]

- (A) $1 - \sqrt{\frac{3}{2}}$
- (B) $1 + \sqrt{\frac{3}{2}}$
- (C) $1 - \sqrt{\frac{2}{3}}$
- (D) $1 + \sqrt{\frac{2}{3}}$

Q.8 Let $f: \left(-\frac{\pi}{2}, \frac{\pi}{2}\right) \rightarrow \mathbb{R}$ be given by

$f(x) = (\log(\sec x + \tan x))^3$. Then

MCQ [IIT-Advance 2014]

- (A) $f(x)$ is an odd function
- (B) $f(x)$ is a one-one function
- (C) $f(x)$ is an onto function
- (D) $f(x)$ is an even function

Q.9 Let $f(x) = \sin\left(\frac{\pi}{6} \sin\left(\frac{\pi}{2} \sin x\right)\right)$ for all $x \in \mathbb{R}$

and $g(x) = \frac{\pi}{2} \sin x$ for all $x \in \mathbb{R}$. Let $(f \circ g)(x)$ denote $f(g(x))$ and $(g \circ f)(x)$ denote $g(f(x))$. Then which of the following is (are) true?

MCQ [IIT-Advance 2015]

- (A) Range of f is $\left[-\frac{1}{2}, \frac{1}{2}\right]$
- (B) Range of $f \circ g$ is $\left[-\frac{1}{2}, \frac{1}{2}\right]$
- (C) $\lim_{x \rightarrow 0} \frac{f(x)}{g(x)} = \frac{\pi}{6}$
- (D) There is an $x \in \mathbb{R}$ such that $(g \circ f)(x) = 1$

Q.10 Let X be a set with exactly 5 elements and Y be a set with exactly 7 elements. If α is the number of one-one functions from X to Y and β is the number of onto functions from Y to X , then the value of $\frac{1}{5!} (\beta - \alpha)$ is _____. [JEE - Advance 2018]

Q.11 Let $E_1 = \left\{ x \in \mathbb{R} : x \neq 1 \text{ and } \frac{x}{x-1} > 0 \right\}$ and

$$E_2 = \left\{ x \in E_1 : \sin^{-1} \left(\log_e \left(\frac{x}{x-1} \right) \right) \text{ is a real number} \right\}$$

(Here, the inverse trigonometric function $\left(\sin^{-1} x \text{ assumes values in } \left[-\frac{\pi}{2}, \frac{\pi}{2} \right] \right)$)

Let $f : E_1 \rightarrow \mathbb{R}$ be the function defined by

$$f(x) = \log_e \left(\frac{x}{x-1} \right) \text{ and } g : E_2 \rightarrow \mathbb{R} \text{ be the}$$

function defined by $g(x) = \sin^{-1} \left(\log_e \left(\frac{x}{x-1} \right) \right)$

[JEE - Advance 2018]

List-I

- (P) The range of f is
- (Q) The range of g contains
- (R) The domain of f contains
- (S) The domain of g is

List-II

(1) $\left(-\infty, \frac{1}{1-e} \right] \cup \left[\frac{e}{e-1}, \infty \right)$

(2) $(0, 1)$

(3) $\left[-\frac{1}{2}, \frac{1}{2} \right]$

(4) $(-\infty, 0) \cup (0, \infty)$

(5) $\left(-\infty, \frac{e}{e-1} \right]$

(6) $(-\infty, 0) \cup \left(\frac{1}{2}, \frac{e}{e-1} \right]$

The correct option is :

- (A) P \rightarrow 4 ; Q \rightarrow 2 ; R \rightarrow 1 ; S \rightarrow 1
- (B) P \rightarrow 3 ; Q \rightarrow 3 ; R \rightarrow 6 ; S \rightarrow 5
- (C) P \rightarrow 4 ; Q \rightarrow 2 ; R \rightarrow 1 ; S \rightarrow 6
- (D) P \rightarrow 4 ; Q \rightarrow 3 ; R \rightarrow 6 ; S \rightarrow 5

Q.12 If the function $f : \mathbb{R} \rightarrow \mathbb{R}$ is defined by $f(x) = |x| (x - \sin x)$, then which of the following statements is **TRUE** ? [JEE - Advance 2020]

- (A) f is one-one, but **NOT** onto
- (B) f is onto, but **NOT** one-one
- (C) f is **BOTH** one-one and onto
- (D) f is **NEITHER** one-one **NOR** onto

Q.13 Let $f : [0, 2] \rightarrow \mathbb{R}$ be the function defined by

$$f(x) = (3 - \sin 2\pi x) \sin \left(\pi x - \frac{\pi}{4} \right) - \sin \left(3\pi x + \frac{\pi}{4} \right).$$

If $\alpha, \beta \in [0, 2]$ are such that $\{x \in [0, 2] : f(x) \geq 0\} = [\alpha, \beta]$, then the value of $\beta - \alpha$ is _____

[JEE - Advance 2020]

Q.14 Let the function $f : [0, 1] \rightarrow \mathbb{R}$ be defined by

$$f(x) = \frac{4^x}{4^x + 2}.$$

$$f\left(\frac{1}{40}\right) + f\left(\frac{2}{40}\right) + f\left(\frac{3}{40}\right) + \dots$$

$$+ f\left(\frac{39}{40}\right) - f\left(\frac{1}{2}\right) \text{ is } \underline{\hspace{2cm}}$$

[JEE - Advance 2020]

Q.15 Let $f : \mathbb{R} \rightarrow \mathbb{R}$ be defined by

$$f(x) = \frac{x^2 - 3x - 6}{x^2 + 2x + 4}$$

Then which of the following statements is (are)

TRUE ? [JEE - Advance 2021]

- (A) f is decreasing in the interval $(-2, -1)$
- (B) f is increasing in the interval $(1, 2)$
- (C) f is onto

(D) Range of f is $\left[-\frac{3}{2}, 2 \right]$

Q.16 Let $f : [0, 1] \rightarrow [0, 1]$ be the function defined by

$$f(x) = \frac{x^3}{3} - x^2 + \frac{5}{9}x + \frac{17}{36}.$$

Consider the square region $S = [0, 1] \times [0, 1]$. Let $G = \{(x, y) \in S : y > f(x)\}$ be called the green region and $R = \{(x, y) \in S : y < f(x)\}$ be called the red region. Let $L_h = \{(x, h) \in S : x \in [0, 1]\}$ be the horizontal line drawn at a height $h \in [0, 1]$. Then which of the following statements is(are) true?

[JEE - Advance 2023]

(A) There exists an $h \in \left[\frac{1}{4}, \frac{2}{3} \right]$ such that the

area of the green region above the line L_h equals the area of the green region below the line L_h

(B) There exists an $h \in \left[\frac{1}{4}, \frac{2}{3} \right]$ such that the

area of the red region above the line L_h equals the area of the red region below the line L_h

(C) There exists an $h \in \left[\frac{1}{4}, \frac{2}{3} \right]$ such that the

area of the green region above the line L_h equals the area of the red region below the line L_h

(D) There exists an $h \in \left[\frac{1}{4}, \frac{2}{3} \right]$ such that the

area of the red region above the line L_h equals the area of the green region below the line L_h

Q.17 Let $f : (0,1) \rightarrow \mathbf{R}$ be the function defined as $f(x) = \sqrt{n}$ if $x \in \left[\frac{1}{n+1}, \frac{1}{n} \right)$ where $n \in \mathbf{N}$. Let

$g : (0,1) \rightarrow \mathbf{R}$ be a function such that $\int_{x^2}^x \sqrt{\frac{1-t}{t}}$

$dt < g(x) < 2\sqrt{x}$ for all $x \in (0,1)$. Then $\lim_{x \rightarrow 0} f(x)g(x)$ **[JEE - Advance 2023]**

- (A) does NOT exist (B) is equal to 1
(C) is equal to 2 (D) is equal to 3

Q.18 Let $n \geq 2$ be a natural number and $f : [0, 1] \rightarrow \mathbf{R}$ be the function defined by

$$f(x) = \begin{cases} n(1-2nx) & \text{if } 0 \leq x \leq \frac{1}{2n} \\ 2n(2nx-1) & \text{if } \frac{1}{2n} \leq x \leq \frac{3}{4n} \\ 4n(1-nx) & \text{if } \frac{3}{4n} \leq x \leq \frac{1}{n} \\ \frac{n}{n-1}(nx-1) & \text{if } \frac{1}{n} \leq x \leq 1 \end{cases}$$

If n is such that the area of the region bounded by the curves $x=0$, $x=1$, $y=0$ and $y=f(x)$ is 4, then the maximum value of the function f is

[JEE - Advance 2023]

Q.19 Let $f : [1, \infty) \rightarrow \mathbf{R}$ be a differentiable function such that $f(1) = \frac{1}{3}$ and $3 \int_1^x f(t)dt = xf(x) - \frac{x^3}{3}$, $x \in [1, \infty)$.

Let e denote the base of the natural logarithm. Then the value of $f(e)$ is **[JEE - Advance 2023]**

- (A) $\frac{e^2+4}{3}$ (B) $\frac{\log_e 4+e}{3}$
(C) $\frac{4e^2}{3}$ (D) $\frac{e^2-4}{3}$

Q.20 Let $f : (0,1) \rightarrow \mathbf{R}$ be the function defined as $f(x) = [4x] \left(x - \frac{1}{4} \right)^2 \left(x - \frac{1}{2} \right)$, where $[x]$ denotes

the greatest integer less than or equal to x . Then which of the following statements is (are) true? **[JEE - Advance 2023]**

- (A) The function f is discontinuous exactly at one point in $(0, 1)$
(B) There is exactly one point in $(0, 1)$ at which the function f is continuous but NOT differentiable
(C) The function f is NOT differentiable at more than three points in $(0, 1)$
(D) The minimum value of the function f is

$$-\frac{1}{512}$$

Q.21 Let $f : \mathbf{R} \rightarrow \mathbf{R}$ and $g : \mathbf{R} \rightarrow \mathbf{R}$ be functions defined by

$$f(x) = \begin{cases} x|x|\sin\left(\frac{1}{x}\right), & x \neq 0, \\ 0, & x = 0, \end{cases} \text{ and}$$

$$g(x) = \begin{cases} 1-2x, & 0 \leq x \leq \frac{1}{2}, \\ 0, & \text{otherwise,} \end{cases}$$

Let $a, b, c, d \in \mathbf{R}$. Define the function $h : \mathbf{R} \rightarrow \mathbf{R}$ by

$$h(x) = af(x) + b \left(g(x) + g\left(\frac{1}{2} - x\right) \right) + c(x - g(x)) +$$

$d g(x)$, $x \in \mathbf{R}$.

Match each entry in **List-I** to the correct entry in **List-II**.

	List-I	List-II
(P)	If $a = 0$, $b = 1$, $c = 0$, and $d = 0$, then	(1) h is one-one
(Q)	If $a = 1$, $b = 0$, $c = 0$, and $d = 0$, then	(2) h is onto
(R)	If $a = 0$, $b = 0$, $c = 1$, and $d = 0$, then	(3) h is differentiable on \mathbf{R}
(S)	If $a = 0$, $b = 0$, $c = 0$, and $d = 1$, then	(4) the range of h is $[0, 1]$
		(5) the range of h is $\{0, 1\}$

The correct option is **[JEE - Advanced 2024]**

- (A) (P) \rightarrow (4), (Q) \rightarrow (3), (R) \rightarrow (1), (S) \rightarrow (2)
(B) (P) \rightarrow (5), (Q) \rightarrow (2), (R) \rightarrow (4), (S) \rightarrow (3)
(C) (P) \rightarrow (5), (Q) \rightarrow (3), (R) \rightarrow (2), (S) \rightarrow (4)
(D) (P) \rightarrow (4), (Q) \rightarrow (2), (R) \rightarrow (1), (S) \rightarrow (3)

Q.22 Let $f : \mathbf{R} \rightarrow \mathbf{R}$ be a function defined by

$$f(x) = \begin{cases} x^2 \sin\left(\frac{\pi}{x^2}\right), & \text{if } x \neq 0, \\ 0, & \text{if } x = 0 \end{cases}$$

Then which of the following statement is TRUE?

[JEE - Advanced 2024]

- (A) $f(x) = 0$ has infinitely many solutions in the interval $\left[\frac{1}{10^{10}}, \infty \right)$.
(B) $f(x) = 0$ has no solutions in the interval $\left[\frac{1}{\pi}, \infty \right)$.
(C) The set of solutions of $f(x) = 0$ in the interval $\left(0, \frac{1}{10^{10}} \right)$ is finite.
(D) $f(x) = 0$ has more than 25 solutions in the interval $\left(\frac{1}{\pi^2}, \frac{1}{\pi} \right)$.

Q.23 Let $f : \mathbb{R} \rightarrow \mathbb{R}$ be a function such that $f(x + y) = f(x) + f(y)$ for all $x, y \in \mathbb{R}$, and $g : \mathbb{R} \rightarrow (0, \infty)$ be a function such that $g(x + y) = g(x)g(y)$ for all $x, y \in \mathbb{R}$. If

$$f\left(\frac{-3}{5}\right) = 12 \text{ and } g\left(\frac{-1}{3}\right) = 2, \text{ then the value of}$$

$$\left(f\left(\frac{1}{4}\right) + g(-2) - 8\right)g(0) \text{ is } \underline{\hspace{2cm}}.$$

[JEE - Advanced 2024]

Q.24 Let the function $f : [1, \infty) \rightarrow \mathbb{R}$ be defined by

$$f(t) =$$

$$\begin{cases} (-1)^{n+1}2, & \text{if } t = 2n - 1, n \in \mathbb{N}, \\ \frac{(2n+1-t)}{2}f(2n-1) + \frac{(t-(2n-1))}{2}f(2n+1), & \text{if } 2n-1 < t < 2n+1, n \in \mathbb{N}. \end{cases}$$

Define $g(x) = \int_1^x f(t)dt$, $x \in (1, \infty)$. Let α denote

the number of solutions of the equation $g(x) = 0$

in the interval $(1, 8]$ and $\beta = \lim_{x \rightarrow 1^+} \frac{g(x)}{x-1}$. Then

the value of $\alpha + \beta$ is equal to $\underline{\hspace{2cm}}$.

[JEE - Advanced 2024]

EXERCISE (Level-6)

Review Exercise

- Q.1** Find the natural number 'a' for which $\sum_{k=1}^n f(a+k) = 16(2^n - 1)$, where the function 'f' satisfies the relation $f(x+y) = f(x)f(y)$ for all natural numbers x, y and further $f(1) = 2$.
[IIT-1992]
- Q.2** A function $f : \mathbb{R} \rightarrow \mathbb{R}$, where \mathbb{R} , is the set of real numbers, is defined by $f(x) = \frac{\alpha x^2 + 6x - 8}{\alpha + 6x - 8x^2}$. Find the interval of values of α for which $f(x)$ is onto. Is the functions one-to-one for $\alpha = 3$? Justify your answer. [IIT 1996]
- Q.3** Let $f(x) = [x] \sin\left(\frac{\pi}{[x+1]}\right)$, where $[.]$ denotes the greatest integer function. Then find the domain of f . [IIT 1996]
- Q.4** If f is an even function defined on the interval $(-5, 5)$, then four real values of x satisfying the equation $f(x) = f\left(\frac{x+1}{x+2}\right)$ are and [IIT-1996]
- Q.5** If the function $f : [1, \infty) \rightarrow [1, \infty)$ is defined by $f(x) = 2^{x(x-1)}$, then find the value of $f^{-1}(x)$. [IIT 99]
- Q.6** Let $[x]$ be the greatest integer less than or equal to x . If all the values of x such that the product $\left[x - \frac{1}{2}\right] \left[x + \frac{1}{2}\right]$ is prime, belongs to the set $[x_1, x_2) \cup [x_3, x_4)$, find the value of $x_1^2 + x_2^2 + x_3^2 + x_4^2$.
- Q.7** The set of real values of 'x' satisfying the equality $\left[\frac{3}{x}\right] + \left[\frac{4}{x}\right] = 5$ (where $[.]$ denotes the greatest integer function) belongs to the interval $\left(a, \frac{b}{c}\right]$ where $a, b, c \in \mathbb{N}$ and $\frac{b}{c}$ is in its lowest form. Find the value of $a + b + c + abc$.
- Q.8** Let $f : \mathbb{R} \rightarrow \mathbb{R} - \{3\}$ be a function with the property that there exist $T > 0$ such that $f(x+T) = \frac{f(x)-5}{f(x)-3}$ for every $x \in \mathbb{R}$. Prove that $f(x)$ is periodic.
- Q.9** In a function $2f(x) + xf\left(\frac{1}{x}\right) - 2f\left(\left|\sqrt{2} \sin\left(\pi\left(x + \frac{1}{4}\right)\right)\right|\right) = 4 \cos^2 \frac{\pi x}{2} + x \cos \frac{\pi}{x}$. Prove that
(i) $f(2) + f\left(\frac{1}{2}\right) = 1$
(ii) $f(2) + f(1) = 0$
- Q.10** Verify if $f(x) = \frac{x^2 - 8x + 18}{x^2 + 4x + 30}$ is an one-one function.
- Q.11** Find the domain of the function, $f(x) = \frac{1}{[|x-1|] + [7-x] - 6}$. Where $[.]$ is greatest integer function.
- Q.12** Let n be a positive integer and define $f(n) = 1! + 2! + 3! + \dots + n!$, where $n! = n(n-1)(n-2) \dots 3 \cdot 2 \cdot 1$. Find the polynomial $P(x)$ and $Q(x)$ such that $f(n+2) = P(n)f(n+1) + Q(n)f(n)$, for all $n \geq 1$.
- Q.13** Find the domain of $y = \sqrt{-\log_{\frac{x+4}{2}}\left(\log_2 \frac{2x-1}{3+x}\right)}$

Passage (Q.14 & 15)

If notation $[x]$ denotes least integer greater than or equal to x and $(.)$ denotes greatest integer less than or equal to x , then

- Q.14** The solution set of the equation $(x)^2 + [x]^2 = [x - 1]^2 + (x + 1)^2$ is -
- (A) $\{x; x \in \mathbb{R}\}$ (B) $\{x; x \in \mathbb{R} - \mathbb{Z}\}$
(C) $\{x; x \in \mathbb{Z}\}$ (D) $\{x; x \in \phi\}$

- Q.15** Let $f(x) = x + (x) ; x < 0$
 $3x - 2(x) ; x \geq 0$
Range of $\text{sgn } f(x)$ is -
- (A) $\{-1, 0, 1\}$ (B) $\{-1, 1\}$
(C) $\{1, 0\}$ (D) $\{-1, 0\}$

- Q.16** Let A be a set of n distinct elements. Then the total number of distinct functions from A to A is & out of these are onto functions.

[IIT-1985]

ANSWER KEY

EXERCISE (Level-1)

- | | | | | | | |
|---------|---------|---------|---------|---------|---------|---------|
| 1. (A) | 2. (D) | 3. (C) | 4. (D) | 5. (A) | 6. (C) | 7. (B) |
| 8. (C) | 9. (C) | 10. (B) | 11. (C) | 12. (A) | 13. (D) | 14. (C) |
| 15. (A) | 16. (D) | 17. (B) | 18. (D) | 19. (B) | 20. (A) | 21. (B) |
| 22. (C) | 23. (B) | 24. (C) | 25. (A) | 26. (A) | 27. (A) | 28. (B) |
| 29. (B) | 30. (B) | 31. (A) | 32. (D) | 33. (B) | 34. (D) | 35. (A) |
| 36. (A) | 37. (A) | 38. (D) | 39. (C) | 40. (A) | 41. (A) | |

EXERCISE (Level-2)

- | | | | | | | |
|---------|---------|---------|---------|---------|---------|---------|
| 1. (C) | 2. (B) | 3. (B) | 4. (B) | 5. (C) | 6. (B) | 7. (D) |
| 8. (D) | 9. (C) | 10. (A) | 11. (C) | 12. (D) | 13. (B) | 14. (B) |
| 15. (D) | 16. (C) | 17. (D) | 18. (C) | 19. (B) | 20. (B) | 21. (D) |
| 22. (A) | 23. (D) | 24. (B) | 25. (A) | 26. (D) | 27. (A) | 28. (A) |
| 29. (A) | 30. (B) | | | | | |

EXERCISE (Level-3)

- | | | | | | | |
|-------------|---------|---------|---------|-----------|----------|---------|
| 1. (D) | 2. (A) | 3. (D) | 4. (C) | 5. (C) | 6. (B) | 7. (C) |
| 8. (A) | 9. (D) | 10. (C) | 11. (C) | 12. (B) | 13. (B) | 14. (C) |
| 15. (D) | 16. (D) | 17. (C) | 18. (C) | 19. (B) | 20. (B) | 21. (B) |
| 22. (C) | 23. (D) | 24. (C) | 25. (C) | 26. (B) | 27. (A) | 28. (D) |
| 29. (Bonus) | 30. (A) | 31. (D) | 32. (B) | 33. (B) | 34. (C) | 35. (D) |
| 36. (B) | 37. (B) | 38. (A) | 39. (C) | 40. (D) | 41. (C) | 42. (C) |
| 43. (B) | 44. (D) | 45. (D) | 46. (B) | 47. 18.00 | 48. 1440 | 49. (C) |
| 50. (D) | 51. (A) | 52. (B) | 53. (B) | 54. (B) | 55. (B) | 56. (A) |
| 57. (D) | 58. (B) | | | | | |

EXERCISE (Level-4)

Part-A

- | | | | | | | |
|---------------|--------------|---------------|-------------|--------------|----------|------------|
| 1. (A,B,D) | 2. (A,B,C,D) | 3. (A,B) | 4. (A,B,C) | 5. (A,B,C,D) | 6. (A,B) | 7. (B,C,D) |
| 8. (A,B,C,D) | 9. (A,B) | 10. (B,D) | 11. (B,C) | 12. (B,D) | 13. (C) | 14. (B,D) |
| 15. (A,B,C,D) | 16. (B,C,D) | 17. (A,B,C,D) | 18. (A,B,C) | | | |

Part-B

- | | | | |
|---------|---------|---------|---------|
| 19. (D) | 20. (A) | 21. (B) | 22. (C) |
|---------|---------|---------|---------|

Part-C

23. $A \rightarrow R, B \rightarrow P, C \rightarrow S, D \rightarrow Q$ 24. $A \rightarrow Q, B \rightarrow S, C \rightarrow P, D \rightarrow R$
25. $A \rightarrow S, B \rightarrow S, C \rightarrow S, D \rightarrow R$ 26. $A \rightarrow R, B \rightarrow Q,R, C \rightarrow Q, D \rightarrow S$

Part-D

27. (A) 28. (C) 29. (C) 30. (A) 31. (A,B,C,D) 32. (C) 33. (C)
 34. (B) 35. (C) 36. (C) 37. (D) 38. (C)

Part-E

39. 1 40. 1 41. 2 42. 3 43. 3

Part-F

44. (i) $\left[-\frac{5\pi}{4}, -\frac{3\pi}{4}\right] \cup \left[-\frac{\pi}{4}, \frac{\pi}{4}\right] \cup \left[\frac{3\pi}{4}, \frac{5\pi}{4}\right]$ (ii) $\left(-4, -\frac{1}{2}\right) \cup (2, \infty)$ (iii) $(-\infty, -3]$ (iii) $(-\infty, -3]$
 (iv) $(-\infty, -1) \cup [0, \infty)$ (v) $(3 - 2\pi < x < 3 - \pi) \cup (3 < x \leq 4)$
 (vi) $\left(0, \frac{1}{100}\right) \cup \left(\frac{1}{100}, \frac{1}{\sqrt{10}}\right)$ (vii) $(-1 < x < -1/2) \cup (x > 1)$ (vii) $\left[\frac{1-\sqrt{5}}{2}, 0\right) \cup \left[\frac{1+\sqrt{5}}{2}, \infty\right)$
 (ix) $(-3, -1] \cup \{0\} \cup [1, 3)$ (x) $\left(0, \frac{1}{4}\right) \cup \left(\frac{3}{4}, 1\right) \cup \{x : x \in \mathbb{N}, x \geq 2\}$ (xi) $\left(-\frac{1}{6}, \frac{\pi}{3}\right] \cup \left[\frac{5\pi}{3}, 6\right)$
 (xii) $[-3, -2) \cup [3, 4)$ (xiii) $\mathbb{R} - \left\{-\frac{1}{2}, 0\right\}$

(xiv) $2n\pi < x < (2n+1)\pi$ but $x \neq 1$ where n is non-negative integer. (xv) $x \in \{4, 5\}$

45. (i) $D : x \in \mathbb{R}$ $R : [0, 2]$ (ii) $D = \mathbb{R}$; range $[-1, 1]$
 (iii) $D : \{x \mid x \in \mathbb{R}; x \neq -3; x \neq 2\}$ $R : \{f(x) \mid f(x) \in \mathbb{R}, f(x) \neq 1/5; f(x) \neq 1\}$
 (iv) $D : \mathbb{R}$; $R : (-1, 1)$ (v) $D : -1 \leq x \leq 2$; $R : [\sqrt{3}, \sqrt{6}]$
 (vi) $D : x \in (2n\pi, (2n+1)\pi) - \{2n\pi + \frac{\pi}{6}, 2n\pi + \frac{\pi}{2}, 2n\pi + \frac{5\pi}{6}, n \in \mathbb{I}\}$ and Range is $(-\infty, \infty) - \{0\}$
 (vii) $D : [-4, \infty) - \{5\}$; $R : \left(0, \frac{1}{6}\right) \cup \left(\frac{1}{6}, \frac{1}{3}\right)$ (viii) $\left[\frac{\pi}{4}, \pi\right)$ (ix) $\left[\frac{1}{2}, 1\right]$

46. (b) (i), (iii) are identical. 48. $f(x) = \frac{x+1}{x-1}$ 49. $\left(0, \frac{5}{3}\right)$ 50. $[0, 4)$

51. $\begin{cases} -x; & -2 \leq x < 0 \\ 0; & 0 \leq x < 1 \\ 2(x-1); & 1 \leq x \leq 2 \end{cases}$ 52. $\left\{\frac{1}{4}\right\}$

53. $A = \left\{0, \log_3 7, \frac{129}{64}, \frac{33}{16}, \frac{9}{4}, 3, 5, 6\right\}$ and since $f(x)$ is not bijective therefore $f^{-1} : B \rightarrow A$ is not possible.

57. $f \circ (x) \begin{cases} -x \tan x, & -\frac{\pi}{2} \leq x \leq 0 \\ -\frac{\pi}{2}[-x], & -2 \leq x < -\frac{\pi}{2} \end{cases}; f_e(x) = \begin{cases} x \tan x, & -\frac{\pi}{2} \leq x \leq 0 \\ \frac{\pi}{2}[-x], & -2 \leq x < -\frac{\pi}{2} \end{cases}$

$$58. f \circ g(x) = \begin{cases} -(1+x), & 1 \leq x \leq 0 \\ x-1, & 0 < x \leq 2 \end{cases}; g \circ f(x) = \begin{cases} x+1, & 0 \leq x < 1 \\ 3-x, & 1 \leq x \leq 2 \\ x-1, & 2 < x \leq 3 \\ 5-x, & 3 < x < 4 \end{cases}; f \circ f(x) = \begin{cases} x, & 0 \leq x \leq 1 \\ 4-x, & 3 \leq x < 4 \end{cases};$$

$$g \circ g(x) = \begin{cases} -x, & -1 \leq x \leq 0 \\ x, & 0 < x \leq 2 \\ 4-x, & 2 < x \leq 3 \end{cases}$$

59. Domain : [1, 2]; Range : [$\ln 2$, $\ln 4$)

60. (i) neither even nor odd (ii) even (iii) even (iv) even (v) odd

61. (i) π (ii) 2 (iii) $\frac{2\pi}{3}$ (iv) 2π (v) $2^n \pi$ (vi) π

62. $f(x) = 2x^2$

63. 6016

EXERCISE (Level-5)

1. (A) 2. (C) 3. $\left[-\frac{\pi}{2}, -\frac{\pi}{10}\right] \cup \left[\frac{3\pi}{10}, \frac{\pi}{2}\right]$ 4. $A \rightarrow P, R, S; B \rightarrow Q, S; C \rightarrow Q, S; D \rightarrow P, R, S$
5. (A) 6. (B) 7. (This question was awarded as bonus) 8. (A, B, C) 9. (A, B, C)
10. 119.00 11. (A) 12. (C) 13. 1.00 14. 19.00 15. (A, B)
16. (B, C, D) 17. (C) 18. 8 19. (C) 20. (A, B) 21. (C) 22. (D)
23. [51.00] 24. [5.00]

EXERCISE (Level-6)

1. $\alpha = 3$ 2. $\alpha \in \phi$ 3. $\{x \in \mathbb{R} \mid x \notin [-1, 0)\}$ 4. $\frac{\pm 3 \pm \sqrt{5}}{2}$ 5. $\frac{1}{2} \left(1 + \sqrt{1 + 4 \log_2 x}\right)$
6. 11 7. 20 10. No 11. $\mathbb{R} - (0, 1) \cup \{1, 2, 3, 4, 5, 6, 7\} \cup (7, 8)$
12. $P(x) = x + 3, Q(x) = -(x + 2)$ 13. $(-4, -3) \cup (4, \infty)$ 14. (B) 15. (A)
16. $n^n, n!$

STUDY MATERIAL

JEE

FOR MAIN & ADVANCED

PHYSICS

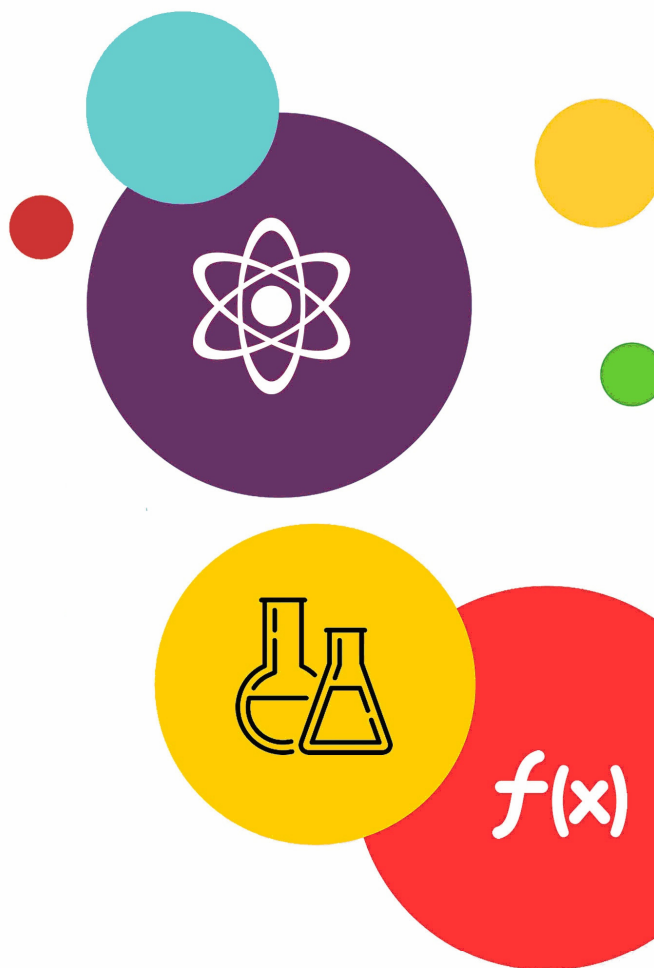

 CP PUBLICATION

PHYSICS

Study Material for JEE Main & Advanced preparation
Prepared by Career Point Kota Experts



CAREER POINT

CONTENTS OF THE PACKAGE AT A GLANCE

PHYSICS

Class 11

Mechanics (Part-I)

- ◆ Essential Mathematics & Vectors
- ◆ Unit & Dimension
- ◆ Motion in One dimension
- ◆ Projectile motion
- ◆ Laws of motion
- ◆ Friction

Mechanics (Part-II)

- ◆ Circular Motion
- ◆ Work, Power, Energy
- ◆ Conservation Laws
- ◆ Rotational motion
- ◆ Gravitation
- ◆ S.H.M.
- ◆ Properties of matter
- ◆ Fluid Mechanics

Heat & Wave

- ◆ Calorimetry
- ◆ K.T.G.
- ◆ Thermodynamics
- ◆ Heat Transfer
- ◆ Thermal expansion
- ◆ Transverse wave
- ◆ Sound wave
- ◆ Doppler's Effect

Class 12

Electrodynamics

[A]

- ◆ Electrostatics
- ◆ Gauss's Law
- ◆ Capacitance
- ◆ Current Electricity

[B]

- ◆ Magnetic Effect of Current
- ◆ Magnetism and Matter
- ◆ E.M.I.
- ◆ Alternating Current
- ◆ Electromagnetic wave

Optics

- ◆ Reflection at Plane & Curved surface
- ◆ Refraction at Plane surface
- ◆ Prism (Dispersion & Deviation)
- ◆ Refraction at Curved surface
- ◆ Wave nature of Light : Interference
- ◆ Diffraction
- ◆ Polarization
- ◆ Optical Instrument

Modern Physics

- ◆ Atomic Structure & Matter Waves
- ◆ Nuclear Physics & Radioactivity
- ◆ Photoelectric Effect & x-Rays
- ◆ Semiconductor & Electronic Devices
- ◆ Practical Physics

Note to the Students

Career Point offers this must have Study Package in Physics to meet the complete curriculum needs of engineering aspirants. The set comprises of 6 books: **Physics** - set of 3 books for class 11 and set of 3 books for Class 12. The set caters to the different requirements of students in classes XI and XII. It offers complete and systematic coverage of **JEE Main** and **JEE Advanced** syllabi and aims to provide firm foundation in learning and develop competitive edge in preparation of the JEE and other engineering entrance examinations.

COMPONENTS OF EACH CHAPTER

These books are designed with an engaging and preparation-focused pedagogy and offer a perfect balance of conceptual learning and problem solving skills.

Theory & Concepts

Each chapter consists of high quality theory that covers all the topics, sub-topics and concepts of JEE syllabus.

Current Electricity

1. ELECTRIC CURRENT

- (a) It is the time rate of flow of charge through a conductor when there is net transfer of charge (say Δq) across a cross section during a time interval (say Δt), we define average electric current as

$$I_{av} = \frac{\Delta q}{\Delta t}$$

- (b) We can also define instantaneous current at any instant 't' as $I_{in} = \frac{dq}{dt}$

- (c) If magnitude and direction of I_{in} does not change with time then 't' is said to be **steady state current** or **direct current**.

- (d) Current is one of the seven fundamental quantities. The S.I. unit of current is ampere.

$$1 \text{ Ampere} = \frac{1 \text{ Coulomb}}{1 \text{ Second}}$$

- (e) The conventional direction of current is along the direction of flow of positive charge and opposite to motion of negative charge.

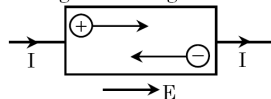

- (f) When charge flow a cross section, the principle of conservation of charge is not violated. Hence a current carrying conductor always remains uncharged. This is also why current does not change with change in cross-section.

- (g) Though current has direction. It is a scalar quantity because -

- It does not obey laws of vector addition.
- Its direction merely represents the sense of flow of charge.

- (h) To generate electric current one must have a source of charge carriers and source of energy (or emf).

Type of Material	Charge Carries
Metal	Free electrons
Semiconductors	Free electrons & holes
Gas / Electrolyte	+ve and -ve ions

NOTE → Electric field inside an electrostatically charge conductor is zero. However in a current carrying conductor internal electric field is created by the source of emf. This is why in electrostatics the dielectric constant of conductor is infinite but not in current electricity.

Example Based on

Circulatory motion of charge

Example. 1

In hydrogen atom, the electron moves in an orbit of radius 0.5 \AA with a speed of $2.2 \times 10^6 \text{ m/s}$. The equivalent current will be.

- (A) 1.12 mA (B) 4.32 mA
(C) 3.32 mA (D) 7.12 mA

Solution.(A)

$$I = \frac{\text{charge}}{\text{time}} = \text{charge on electron} \times \text{frequency of}$$

$$\text{oscillation} = \text{e.f.} = e \cdot \frac{\omega}{2\pi} = \frac{ev}{2\pi r}$$

Example. 2

A non-conducting ring of radius R carries linear charge density λ . The ring rotates with constant angular velocity ω (about its central axis). What will be the equivalent current ?

- (A) $\lambda R \omega$ (B) $2\pi R \omega / \lambda$
(C) $\frac{\lambda \omega}{2\pi}$ (D) None

Solution.(A)

Total charge on the ring = $2\pi R \lambda$. Take any point A on the ring. As the ring rotates about the given axis, total charge crossing the point A in every rotation will be $Q = 2\pi R \lambda$.

Therefore by definition of current.

$$I = \frac{Q}{T} = Q f = Q \frac{\omega}{2\pi} = 2\pi R \lambda \cdot \frac{\omega}{2\pi} = \lambda R \omega$$

2. CURRENT DENSITY

- (a) The current density at a point is defined as a vector having magnitude equal to current per unit area surrounding that point and normal to the direction of charge flow. It is represented by \vec{J} .

- (b) At a point P if current I passes normally through area dA (see figure), then $\vec{J} = \frac{d\vec{I}}{dA}$

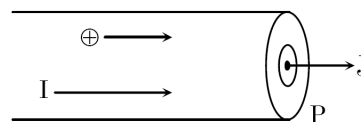

- (c) The direction of current density is the direction of motion of positive charge at the point P.

Important Points

This part contains important concepts & formulas of chapter at one place in short manner, So that student can revise all these in short time.

♦ Important Points

- (a) A conducting device obeys ohm's law only if its physical state remains unchanged. In this case the graph between I and V is a straight line passing through origin ($\because V \propto I$). Such a conductor (e.g. metals, alloys etc) is called ohmic-conductor having resistance (R) equal to reciprocal of slope of I-V. curve (see figure)

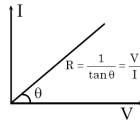

- (b) Resistance of ohmic conductor is independent of applied voltage hence it is also called **static resistance**.
- (c) For other substances such as gases, semiconductors, electrolytes etc, the I-V curve is not a straight line. Hence they are called nonohmic conductors. (see figure)

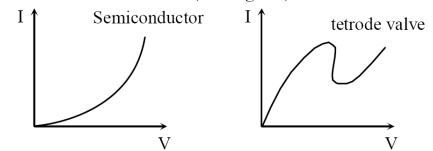

- (d) For non ohmic conductors it is not possible to determine static resistance (R) as the curve has different slopes at different voltage.

- (e) Therefore for these we define **dynamic resistance (r)** as ratio of change in voltage to change in current at a given voltage. It is also measured in ohm.

$$r = \frac{\Delta V}{\Delta I}$$

- (f) Remember that static resistance R can never be negative, but dynamic resistance r may have negative value (as in case of tetrode valve)

Solved Examples (JEE Main/Advanced)

To understand the application of concepts, there is a solved example section. It contains large variety of all types of solved examples with explanation to ensure understanding the application of concepts.

SOLVED EXAMPLES

- Ex.1** A network of nine conductors connects six points A, B, C, D, E and F as shown. The figures denote resistances in ohms. The equivalent resistance between A and D is

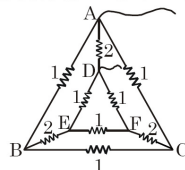

- Sol.** B and c are equipotential points and so are E and F. Here the circuit can be redrawn as shown in Figure. 1Ω and 1Ω in parallel sum up to $1/2W$; $2W$ and $2W$ in parallel sum up to $1W$; $1/2W$, $1W$, $1/2W$ in series sum up to $1/2 + 1 + 1/2 = 2\Omega$; 2Ω and 2Ω in parallel sum up to $= 1\Omega$.

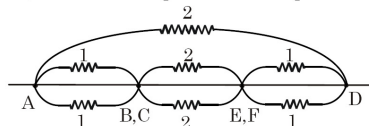

- Ex.2** In the network shown in the figure below, calculate the potential difference between A and B.

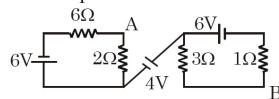

- Sol.** The distribution of current is shown in Fig., keeping in view that the inflow and outflow of current in a cell must be the same. Applying the loop rule to the left and right loops.

- Sol.** Symmetry about entrance point 1 and exit point 7 shows that 2, 4, 5 are equipotential points and 5, 6, and 8 are equipotential points. Hence the circuit can be redrawn as shown in Figure. The resistance r, r and r in parallel sum up to $r/3$.

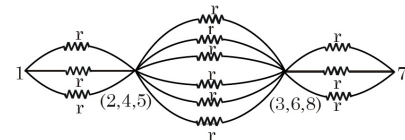

r, r, r, r, r, r in parallel sum up to $r/6$ and r, r, r in parallel sum up to $r/3$. Next $r/3, r/6, r/3$ in series sum up to $5r/6$.

- Ex.4** Two resistors with temperature coefficients of resistance α_1 and α_2 have resistances R_{01} and R_{02} at 0°C . Find the temperature coefficient of the compound resistor consisting of the two resistors connected in parallel.

Sol. $R_1 = R_{01}(1 + \alpha_1 t)$

and $R_2 = R_{02}(1 + \alpha_2 t)$

Also $R = \frac{R_1 R_2}{R_1 + R_2} = R_0(1 + \alpha t)$

and $R_0 = \frac{R_{01} R_{02}}{R_{01} + R_{02}}$

$\therefore \frac{R_{01} R_{02}}{R_{01} + R_{02}} (1 + \alpha t)$

Practice Exercises

Exercise Level - 1 : It contains objective questions with single correct choice to ensure sufficient practice to accurately apply formulae and concepts.

Exercise Level - 2 : It contains single objective type questions with moderate difficulty level to enhance the conceptual and application level of the student.

Exercise Level - 3 : It contains previous years question of JEE Main from Year 2005 to 2024.

EXERCISE (Level-3)

Old Examination Questions [JEE Main]

Q.1 A moving coil galvanometer has 150 equal divisions. Its current sensitivity is 10 divisions per milliampere and voltage sensitivity is 2 divisions per millivolt. In order that each division reads 1 volt, the resistance in ohms needed to be connected in series with the coil will be -

[AIEEE-2005]

- (A) 10^3 (B) 10^5 (C) 99995 (D) 9995

Q.2 In the circuit, the galvanometer G shows zero deflection. If the batteries A and B have negligible internal resistance, the value of the resistor R will be -

[AIEEE-2005]

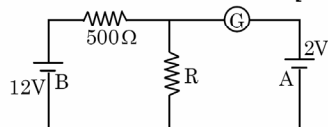

- (A) 200 Ω (B) 100 Ω (C) 500 Ω (D) 1000 Ω

Q.3 Two sources of equal emf are connected to an external resistance R. The internal resistances of the two sources are R_1 and R_2 ($R_2 > R_1$). If the potential difference across the source having internal resistance R_2 is zero, then -

[AIEEE-2005]

- (A) $R = R_2 \times (R_1 + R_2) / (R_2 - R_1)$
 (B) $R = R_2 - R_1$
 (C) $R = R_1 R_2 / (R_1 + R_2)$
 (D) $R = R_1 R_2 / (R_2 - R_1)$

Q.4 An energy source will supply a constant current into the load if its internal resistance is -

[AIEEE-2005]

- (A) equal to the resistance of the load
 (B) very large as compared to the load resistance
 (C) zero
 (D) non-zero but less than the resistance of the load

Q.5 In a potentiometer experiment the balancing with a cell is at length 240 cm. On shunting the cell with a resistance of 2 Ω, the balancing length becomes 120 cm. The internal resistance of the cell is -

[AIEEE-2005]

- (A) 1 Ω (B) 0.5 Ω (C) 4 Ω (D) 2 Ω

Q.6 A material 'B' has twice the specific resistance of 'A'. A circular wire made of 'B' has twice the diameter of a wire made of 'A'. Then for the two wires to have the same resistance, the ratio l_B/l_A of their respective lengths must be -

[AIEEE-2006]

- (A) $\frac{1}{4}$ (B) 2 (C) 1 (D) $\frac{1}{2}$

- (A) conservation of momentum, conservation of charge
 (B) conservation of charge, conservation of energy
 (C) conservation of charge, conservation of momentum
 (D) conservation of energy, conservation of charge

Q.8 The current I drawn from the 5 volt source will be -

[AIEEE-2006]

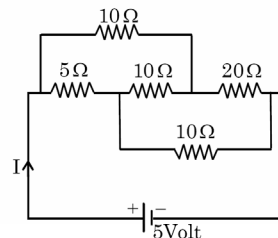

- (A) 0.67 A (B) 0.17 A (C) 0.33 A (D) 0.5 A

Q.9 In a Wheatstone's bridge, three resistances P, Q and R are connected in the three arms and the fourth arm is formed by two resistances S_1 and S_2 connected in parallel. The condition for the bridge to be balance will be -

[AIEEE-2006]

- (A) $\frac{P}{Q} = \frac{R(S_1 + S_2)}{2S_1 S_2}$ (B) $\frac{P}{Q} = \frac{R}{S_1 + S_2}$
 (C) $\frac{P}{Q} = \frac{2R}{S_1 + S_2}$ (D) $\frac{P}{Q} = \frac{R(S_1 + S_2)}{S_1 S_2}$

Q.10 An electric bulb is rated 220 volt – 100 watt. The power consumed by it when operated on 110 volt will be -

[AIEEE-2006]

- (A) 25 watt (B) 50 watt
 (C) 75 watt (D) 40 watt

Q.11 The resistance of wire is 5 ohm at 50°C and 6 ohm at 100°C. The resistance of the wire at 0°C will be -

[AIEEE-2007]

- (A) 2 ohm (B) 1 ohm (C) 4 ohm (D) 3 ohm

Q.12 A 5 V battery with internal resistance 2 Ω and a 2V battery with internal resistance 1Ω are connected to a 10Ω resistor as shown in the figure.

[AIEEE-2008]

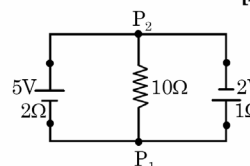

Exercise Level - 4 : It contains all variety of questions as per level of JEE Advanced such as MCQ, Column match, Passage based & Numerical type etc.

EXERCISE (Level-4)

Part-A : Multiple correct answer type questions

- Q.1** Two circuits (as shown in figure) are called circuit A and circuit B. The equivalent resistance of circuit A is x and that of circuit B is y between 1 and 2.

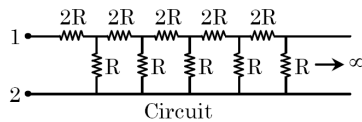
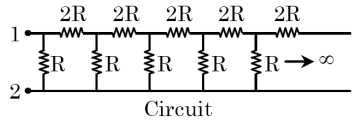

- (A) $y > x$ (B) $y = (\sqrt{3} + 1) R$
 (C) $xy = 2R^2$ (D) $y - x = 2R$
- Q.2** Study the following circuit diagram in figure and mark the correct options.
 $V = 18.0 \text{ V}$

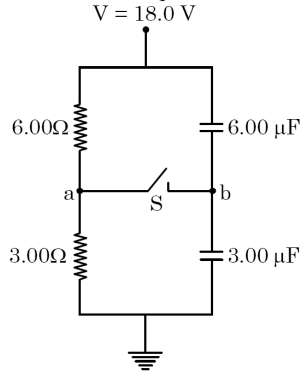

- (A) The potential of point a with respect to point b in the figure when switch S is open is -6V .
 (B) The points a and b are at the same potential, when S is opened.
 (C) The charge flowing through switch S when it is closed is $54 \mu\text{C}$.
 (D) The final potential of b with respect to ground when switch S is closed is 8 V .
- Q.3** In the given circuit (as shown in figure)

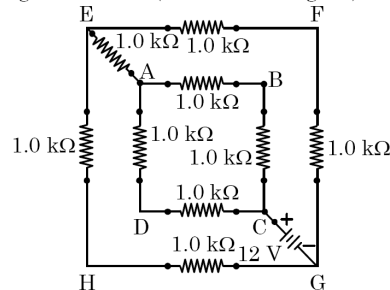

- (A) the equivalent resistance between C and G

- (B) the current provided by the source is 4 mA
 (C) the current provided by the source is 8 mA
 (D) voltage across points G and E is 4 V

- Q.4** In the circuit shown in figure, mark the correct option.

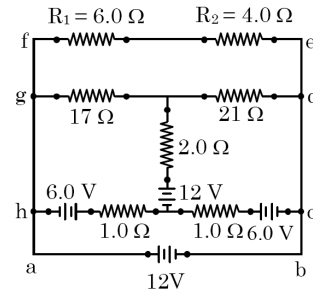

- (A) potential drop across R_1 is 3.2 V
 (B) Potential drop across R_2 is 5.4 V
 (C) Potential drop across R_1 is 7.2 V
 (D) Potential drop across R_2 is 4.8 V

- Q.5** Consider a simple circuit shown in figure stands for a variable resistance R' . R' can vary from R_0 to infinity, r is internal resistance of the battery ($r \ll R \ll R'$).

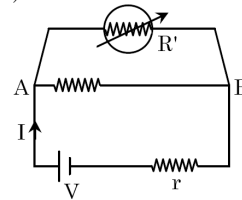

- (A) Potential drop across, AB is nearly constant as R' is varied
 (B) Current through R' is nearly a constant as R' is varied
 (C) Current I depends sensitively on R'
 (D) $I \geq \frac{V}{r + R}$ always

- Q.6** When no current is passed through a conductor—
 (A) the free electrons do not move
 (B) the average speed of free electrons over a large period of time is zero
 (C) the average velocity of free electrons over a large period of time is zero
 (D) the average of the velocities of all the free electrons at an instant is zero

- Q.7** A current passes through a wire of non-uniform cross-section. Which of the following quantities are independent of the cross-section —
 (A) the charge crossing in a given time interval
 (B) drift velocity
 (C) current density

Exercise Level - 5 : It contains previous years question of JEE Advanced from Year 2005 to 2024.

EXERCISE (Level-5)

Old Examination Questions [JEE Advanced]

- Q.1** In the given circuit the switch S is closed at time $t = 0$. The charge Q on the capacitor at any instant t is given by $Q(t) = Q_0(1 - e^{-\alpha t})$. Find the value of Q_0 and α in terms of given parameters as shown in the circuit. [IIT-JEE 2005]

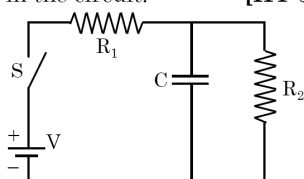

- Q.2** An unknown resistance is to be determined using resistance R_1 , R_2 , and R_3 . If their corresponding null points are A, B and C. Which of the following will give most accurate reading? [IIT-JEE 2005]

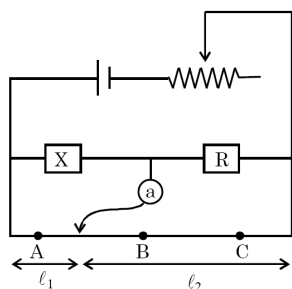

- Q.3** A galvanometer having Resistance 100Ω is used to form an ammeter with the help of resistance 0.1Ω . The maximum deflection of galvanometer is at $100 \mu\text{A}$. Find the smallest current when Galvanometer shows maximum deflection- [IIT-JEE 2005]
- (A) 100.1 mA (B) 1000.1 mA
 (C) 10.01 mA (D) 1.001 mA

- Q.4** A $4 \mu\text{F}$ capacitor, a resistance of $2.5 \text{ M}\Omega$ is in series with 12 V battery. Find the time after which the potential difference across the capacitor is 3 times the potential difference across the resistor [IIT-JEE 2005]
- [Given $\ln(2) = 0.693$]
 (A) 13.86 s (B) 6.93 s (C) 7 s (D) 14 s

- Q.5** An ideal gas is filled in a closed rigid and thermally insulated container. A coil of 100Ω resistor carrying current 1 A for 5 minutes supplies heat to the gas. The change in internal energy of the gas is - [IIT-JEE 2005]
- (A) 10 kJ (B) 30 kJ (C) 20 kJ (D) 0 kJ

- Q.6** Consider a cylindrical element as shown in the figure. Current flowing through element is i and resistivity of material of the cylinder is ρ . Choose the correct option out the following - [IIT-JEE 2006]

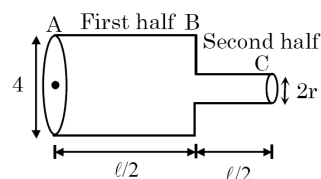

- (A) Power loss in second half is four times the power loss in first half
 (B) Voltage drop in first half is twice of voltage drop in second half
 (C) Current density in both halves are equal
 (D) Electric field in both halves is equal
- Q.7** Time constant for the given circuits are - [IIT-JEE 2006]

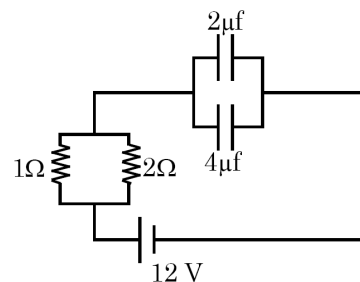
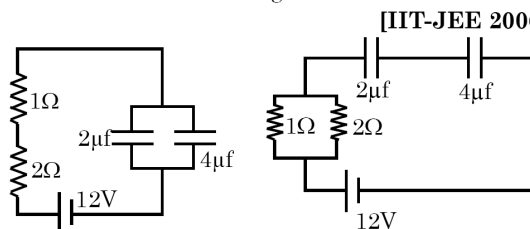

- (A) $18 \mu\text{s}$, $\frac{8}{9} \mu\text{s}$, $4 \mu\text{s}$ (B) $18 \mu\text{s}$, $4 \mu\text{s}$, $\frac{8}{9} \mu\text{s}$
 (C) $4 \mu\text{s}$, $\frac{8}{9} \mu\text{s}$, $18 \mu\text{s}$ (D) $\frac{8}{9} \mu\text{s}$, $18 \mu\text{s}$, $4 \mu\text{s}$
- Q.8** A parallel plate capacitor C with plates of uni area and separation d is filled with a liquid of dielectric constant $K = 2$. The level of liquid is $d/3$ initially. Suppose the liquid level decreases at a constant speed V , the time constant as a function of time t is - [IIT-JEE 2008]

Exercise Level - 6 : Advanced level a bit complex questions for students for solid rock preparation for Top Rankers.

Answer key

Answer key is provided at the end of the exercise sheets.

ANSWER KEY									
EXERCISE (Level-1)									
1. (B)	2. (C)	3. (A)	4. (B)	5. (B)	6. (C)	7. (C)	8. (C)	9. (B)	10. (D)
11. (B)	12. (B)	13. (C)	14. (A)	15. (A)	16. (C)	17. (C)	18. (D)	19. (B)	20. (A)
21. (A)	22. (B)	23. (C)	24. (A)	25. (B)	26. (B)	27. (B)	28. (B)	29. (B)	30. (B)
31. (C)	32. (D)	33. (B)	34. (A)	35. (C)	36. (B)	37. (B)	38. (C)	39. (B)	40. (D)
41. (C)	42. (C)								

Revision Plan

We emphasize that every student should prepare his/her own revision plan. For this purpose there is Revision Plan Section in each chapter which student should prepare while going through the study material. This will be useful at the time of final revision before final exam for quick & effective revision.

Revision Plan

Prepare Your Revision plan today!

After attempting Exercise Sheet, please fill below table as per the instruction given.

- Write Question Number (QN) which you are unable to solve at your own in **column A**.
- After discussing the Questions written in **column A** with faculty, strike off them in the manner so that you can see at the time question number during Revision, to solve such questions again.
- Write down the Question Number you feel are important or good in the **column B**.

EXERCISE	COLUMN A	COLUMN B
	Questions unable to solve in first attempt	Good or Important questions
Topic wise practice questions		
Level-1		
Level-2		
Level-3		
Level-4		
Level-5		
Level-6		

Revision Strategy:

Whenever you wish to revision this chapter, follow the following steps-

Step-1: Review your theory notes.

Step-2: Solve Questions of column A

Online Solutions

Self explanatory and detailed solution of all exercises above are available on Career Point website www.careerpoint.ac.in

CURRENT ELECTRICITY EXERCISE (Level-1)

Answer Key & Solution

Question Number	Solution
1	Click Here
2	Click Here
3	Click Here
4	Click Here
5	Click Here
6	Click Here
7	Click Here
8	Click Here
9	Click Here
10	Click Here
11	Click Here

Question Number	Solution
12	Click Here
13	Click Here
14	Click Here
15	Click Here
16	Click Here
17	Click Here
18	Click Here
19	Click Here
20	Click Here
21	Click Here
22	Click Here

Question Number	Solution
23	Click Here
24	Click Here
25	Click Here
26	Click Here
27	Click Here
28	Click Here
29	Click Here
30	Click Here
31	Click Here
32	Click Here
33	Click Here

Question Number	Solution
34	Click Here
35	Click Here
36	Click Here
37	Click Here
38	Click Here
39	Click Here
40	Click Here
41	Click Here
42	Click Here

Sol.1 [B]

Given

$$\begin{aligned}I &= 1.1 \text{ A} \\e &= 1.6 \times 10^{-19} \text{ C} \\A &= \pi r^2 = \pi \times (0.05)^2 \\&= 78.5 \times 10^{-4} \text{ cm}^2\end{aligned}$$

$$v_d = \frac{I}{neA}$$

$$n = \frac{6 \times 10^{23}}{7 \text{ cm}^3} = 0.86 \times 10^{23} / \text{m}^3$$

$$v_d = \frac{1.1}{0.86 \times 1.6 \times 10^{-19} \times 78.5 \times 10^{-4}}$$

(volume of 63g Cu)

$$\begin{aligned}v_d &= 0.01 \text{ cm/s.} \\&= 0.1 \text{ mm/s}\end{aligned}$$

[Top](#)

CURRENT ELECTRICITY

JEE ADVANCED SYLLABUS

1. *Ohm's law*
2. *Series and parallel arrangements of resistances and cells*
3. *Kirchhoff's laws and applications to networks*
4. *charging and discharging of capacitor*
5. *Heating effect of current*

Revision Plan

Prepare Your Revision plan today!

After attempting Exercise Sheet, please fill below table as per the instruction given.

- A. Write Question Number (QN) which you are unable to solve at your own in **column A**.
- B. After discussing the Questions written in **column A** with faculty, strike off them in the manner so that you can see at the time question number during Revision, to solve such questions again.
- C. Write down the Question Number you feel are important or good in the **column B**.

EXERCISE	COLUMN A	COLUMN B
	Questions unable to solve in first attempt	Good or Important questions
Level-1		
Level-2		
Level-3		
Level-4		
Level-5		
Level-6		

Revision Strategy :

Whenever you wish to revision this chapter, follow the following steps-

Step-1: Review your theory notes.

Step-2: Solve Questions of column A

Step-3: Solve Questions of Column B

Step-4: Solve questions from other Question Bank, Problem book etc.

Current Electricity

1. ELECTRIC CURRENT

- (a) It is the time rate of flow of charge through a conductor when there is net transfer of charge (say Δq) across a cross section during a time interval (say Δt), we define average electric current as

$$I_{av} = \frac{\Delta q}{\Delta t}$$

- (b) We can also define instantaneous current at any instant 't' as $I_{in} = \frac{dq}{dt}$

- (c) If magnitude and direction of I_{in} does not change with time then 't' is said to be **steady state current** or **direct current**.

- (d) Current is one of the seven fundamental quantities. The S.I. unit of current is ampere.

$$1 \text{ Ampere} = \frac{1 \text{ Coulomb}}{1 \text{ Second}}$$

- (e) The conventional direction of current is along the direction of flow of positive charge and opposite to motion of negative charge.

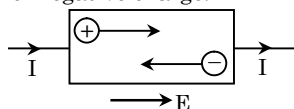

- (f) When charge flow a cross section, the principle of conservation of charge is not violated. Hence a current carrying conductor always remains uncharged. This is also why current does not change with change in cross-section.
- (g) Though current has direction. It is a scalar quantity because -
- It does not obey laws of vector addition.
 - Its direction merely represents the sense of flow of charge.
- (h) To generate electric current one must have a source of charge carriers and source of energy (or emf).

Type of Material	Charge Carries
Metal	Free electrons
Semiconductors	Free electrons & holes
Gas / Electrolyte	+ve and -ve ions

NOTE Electric field inside an electrostatically charge conductor is zero. However in a current carrying conductor internal electric field is created by the source of emf. This is why in electrostatics the dielectric constant of conductor is infinite but not in current electricity.

Example Based on

Circulatory motion of charge

Example. 1

In hydrogen atom, the electron moves in an orbit of radius 0.5 \AA with a speed of $2.2 \times 10^6 \text{ m/s}$. The equivalent current will be.

- (A) 1.12 m A (B) 4.32 m A
(C) 3.32 m A (D) 7.12 m A

Solution.(A)

$$I = \frac{\text{charge}}{\text{time}} = \text{charge on electron} \times \text{frequency of}$$

$$\text{oscillation} = e.f. = e. \frac{\omega}{2\pi} = \frac{ev}{2\pi r}$$

Example. 2

A non-conducting ring of radius R carries linear charge density λ . The ring rotates with constant angular velocity ω (about its central axis). What will be the equivalent current ?

- (A) $\lambda R \omega$ (B) $2\pi R \omega / \lambda$
(C) $\frac{\lambda \omega}{2\pi}$ (D) None

Solution.(A)

Total charge on the ring = $2\pi R \lambda$. Take any point A on the ring. As the ring rotates about the given axis, total charge crossing the point A in every rotation will be $Q = 2\pi R \lambda$.

Therefore by definition of current.

$$I = \frac{Q}{T} = Q f = Q \frac{\omega}{2\pi} = 2\pi R \lambda. \frac{\omega}{2\pi} = \lambda R \omega$$

2. CURRENT DENSITY

- (a) The current density at a point is defined as a vector having magnitude equal to current per unit area surrounding that point and normal to the direction of charge flow. It is represented by \vec{J} .

- (b) At a point P if current I passes normally through area dA (see figure), then $\vec{J} = \frac{d\vec{I}}{dA}$

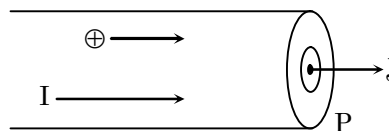

- (c) The direction of current density is the direction of motion of positive charge at the point P.

- (d) Note that the area ΔA is normal to the current ΔI . If ΔA is not normal to I , but makes angle θ with the normal then

$$\vec{J} = \frac{dI}{\text{normal component of area}} = \frac{dI}{dA \cos \theta}$$

$$\Rightarrow dI = J dA \cos \theta \Rightarrow I = \int \vec{J} \cdot d\vec{A}$$

- (e) Unit is ampere/meter² and dimension is $[M^0 L^{-2} T^0 A]$.
 (f) In case of uniform flow of charge current density can also be defined as.

$$J = \frac{I}{A} = n.e.v_d,$$

where n = no. of charge carriers per unit volume.

A = Area of cross-section,

v_d = drift velocity of charge carriers.

- (g) If a source of emf produces electric field inside a conductor of resistivity ρ , then current density at any point inside the conductor is

$$\vec{J} = \frac{\vec{E}}{\rho} = \sigma \vec{E} \quad (\sigma = \frac{1}{\rho} = \text{conductivity}).$$

3. MECHANISM OF CURRENT FLOW IN METALS

- (a) In the absence of potential difference across a conductor.
- Its free electrons ($n \approx 10^{23}$ per cc.) behave identical to molecules of an ideal gas.
 - They move within the lattice-space of the crystal with large thermal speeds given by

$$v_{\text{rms}} = \sqrt{\frac{3kT}{m}} \approx 10^5 \text{ m/s.}$$

where m = mass of electron

- However due to continuous collisions with metal lattice the electrons move in zig-zag fashion. Therefore net transfer of charge across the cross-section is zero. Thus no current flow inside the conductor.
- Here it should be remembered that time interval between two successive collision of an electron is called relaxation time (τ) and the path covered is called mean free path (λ). τ and λ are related as.

$$\tau = \frac{\lambda}{v_{\text{rms}}}$$

- (b) When potential difference is applied between the ends of a conductor it sets up internal electric field ($|\vec{E}| = V/L$). Under the action of the field free electrons start drifting (opposite to) with a constant average velocity. It is known as drift velocity (v_d). Due to drifting of free electrons electric current begins to flow inside the conductor.
- (c) It can be shown that $v = u + at$ here $v = v_d$, $u = \text{initial velocity} = 0$

$$a = F/m = \frac{eE}{m} \quad \{\text{as } F = qE\}$$

$$t = \tau$$

$$v_d = -\frac{eE}{m} \cdot \tau = \frac{eV}{mL} \cdot \tau,$$

where (–ve) sign indicates that electrons move opposite to the field.

Here, $e \rightarrow$ electron charge

$m \rightarrow$ electron mass

$V \rightarrow$ potential difference

$L \rightarrow$ Length of conductor

- (d) Since $v_{\text{rms}} \propto \sqrt{T}$ and $\tau \propto \frac{1}{v_{\text{rms}}}$ hence $\tau \propto \frac{1}{\sqrt{T}}$.

This shows that as the temperature is increased, relaxation time and drift velocity decreases.

NOTE Though magnitude of drift velocity is very small ($\approx 1 \text{ mm / sec}$) it is responsible for the effects of current, magnetic effect, thermal effect etc.

4. RELATION BETWEEN I AND v_d

Consider any cylindrical element of a conductor of area of cross section A . If its free electrons are drifting with velocity v_d , the length of the element swept in time dt will be $v_d dt$. If the conductor has n free electrons per unit volume the number of electron in this volume will be $n(Av_d dt)$.

All these electrons cross the area A in time dt . Thus charge crossing in time dt across time area A is $dQ = n(Av_d dt) e$

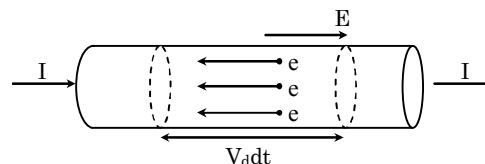

$$\text{or } I = \frac{dQ}{dt}$$

$$I = ne A v_d \quad \text{and} \quad J = \frac{I}{A} = ne v_d$$

5. MOBILITY

- (a) Drift velocity acquired by a charge carrier (free electrons holes, ions etc.) per unit electric field is defined as its mobility. It is denoted by μ .

$$\mu = \frac{v_d}{E} = \frac{e\tau}{m} \quad [\because v_d = \frac{eE}{m} \tau]$$

- (b) It is measured in = $\frac{\text{m/s}}{\text{volt/m}} = \frac{(\text{meter})^2}{\text{volt} \times \text{sec}}$

- (c) Its dimension is $\mu = \frac{(AT)T}{M} = M^{-1} T^2 A^1$

Example Based on**Drift velocity****Example. 3**

One end of an aluminium wire, whose diameter is 2.5 mm is welded to one end of a copper wire whose diameter is 2.0 mm. The composite wire carries a steady current 6.25 A. The current densities in Al and Cu will be respectively -

- (A) 127 A/cm², 200 A/cm² (B) 126 A/cm², 180 A/cm²
 (C) 125 A/cm², 160 A/cm² (D) 125 A/cm², 180 A/cm²

Solution. (A)

$$\therefore J = I/A = \frac{I}{\pi r^2}$$

$$\therefore \text{For Al, } J = \frac{6.25}{\frac{\pi}{4} \times 2.5^2 \times 10^{-6}} = 127 \times 10^6 \text{ A/m}^2$$

$$= 127 \text{ A/cm}^2$$

$$\text{and for copper } J = \frac{6.25}{\frac{\pi}{4} \times 2^2 \times 10^{-6}} = 200 \text{ A/cm}^2$$

Example. 4

A silver wire of 1mm diameter carries a charge of 90 coulombs in 1 hour and 15 minutes. Silver contains 5.8×10^{28} free electrons per cm³. The current (in amp.) in wire and drift velocity of the electron will be respectively -

- (A) 0.02, 2.69×10^{-7} (B) 0.03, 3.69×10^{-7}
 (C) 3.2, 2.69×10^{-7} (D) 2.3, 3.69×10^{-7}

Solution. (A)

$$\therefore i = \frac{q}{t} = \frac{90 \text{ coulombs}}{4500 \text{ sec}} = 0.02 \text{ ampere}$$

$$J = \frac{i}{A} = \frac{i}{\pi r^2} = \frac{0.02 \text{ amp}}{\pi(0.05)^2 \text{ meter}^2}$$

$$= 2.55 \times 10^4 \text{ amp/m}^2$$

$$v_d = \frac{J}{ne} = \frac{2.55 \times 10^4}{(5.8 \times 10^{28})(1.6 \times 10^{-19})}$$

$$= 2.69 \times 10^{-7} \text{ m/sec.}$$

Example. 5

The area of cross-section, length and density of a piece of a metal of atomic weight 60 are 10^{-6} m^2 , 1.0 m and $5 \times 10^{+3} \text{ kg/m}^3$ respectively. Find number of free electrons per unit volume if every atom contributes one free electron and the drift velocity of electron in the metal when the current of 16A passes through it (Given Avogadro number = $6 \times 10^{23}/\text{mole}$)

- (A) $5 \times 10^{28}/\text{m}^3$, $2 \times 10^{-3} \text{ m/s}$
 (B) $2.5 \times 10^{28}/\text{m}^3$, $1 \times 10^{-3} \text{ m/s}$
 (C) $10 \times 10^{28}/\text{m}^3$, $3 \times 10^{-3} \text{ m/s}$
 (D) None of the above.

Solution. (A)

$$\text{Mass of metal} = A \rho d$$

$$[\text{Mass} = \text{Volume} \times \text{density}]$$

$$\therefore m = 10^{-6} \times 1 \times 5 \times 10^3 = 5 \times 10^{-3} \text{ kg}$$

$$\text{Number of atoms in mass } 5 \times 10^{-3} \text{ kg}$$

$$= \frac{Nm}{M} = \frac{(6 \times 10^{23})(5 \times 10^{-3})}{60 \times 10^{-3}} = 5 \times 10^{22}$$

$$\therefore \text{Number of atoms per unit volume}$$

$$= \frac{5 \times 10^{22}}{10^{-6} \text{ m}^3} = 5 \times 10^{28}/\text{m}^3$$

This also represents the number of free electrons. If v_d be the drift velocity,

$$\text{then } i = neAv_d \text{ or } v_d = \frac{i}{neA}$$

$$= \frac{1.6}{(5 \times 10^{28})(1.6 \times 10^{-19})(10^{-6})} = 2 \times 10^{-6} \text{ m/sec}$$

Example. 6

The total momentum of electrons in a straight wire of length $l = 1000\text{m}$ carrying a current $I = 70\text{A}$, will be- (in N.s)

- (A) 0.40×10^{-6} (B) 0.20×10^{-6}
 (C) 0.80×10^{-6} (D) 0.16×10^{-6}

Solution. (A)

$$\text{We know } I = neAv_d$$

where $v_d \rightarrow$ drift velocity,

$n \rightarrow$ density of electron.

$$\text{Total no. of electron } N = nAl$$

$$\text{Total momentum (p) of electron}$$

$$= Nm v_d \text{ or } p = (nAlm) \frac{I}{neA} = \frac{I/m}{e}$$

$$\Rightarrow p = \frac{70 \times 1000 \times 9.3 \times 10^{-31}}{1.6 \times 10^{-19}} = 0.40 \mu \text{ N.s}$$

Example Based on**Current in discharge tube****Example. 7**

A current is established in a gas discharge tube of cross-section $8 \times 10^{-4} \text{ m}^2$ when a sufficiently high potential difference (say 32 kV) is applied across the two electrodes in the tube. The gas ionises, electrons move towards the positive terminal and positive ions towards the negative terminal. What are the magnitude and sense of the current in a hydrogen discharge tube in which 3×10^{18} electrons and 2×10^{18} protons move past cross-sectional area of the tube in each second ?

Solution.

As current is rate of flow of charge in the direction which positive charge will move, the current due to electrons will be

$$I_e = \frac{n_e}{t} \times q_e = 3 \times 10^{18} \times 1.6 \times 10^{-19} = 0.48 \text{ A}$$

in the direction from positive to negative electrode (which is opposite to the motion of electrons). And the current due to protons

$$I_p = \frac{n_p}{t} \times q_p = 2 \times 10^{18} \times 1.6 \times 10^{-19} = 0.32 \text{ A}$$

in the direction from positive to negative electrode (which is also the direction of motion of protons). So the total current

$$I = I_e + I_p = 0.48 + 0.32 = 0.8 \text{ A}$$

Ans.

from anode to cathode of discharge tube.

Example Based on

Mobility

Example. 8

The air gap between two parallel plates separated by a distance $d = 2 \text{ cm}$ is ionized by X-rays. Each plate has an area $S = 500 \text{ cm}^2$. Find the concentration of positive ions if a voltage $V = 100 \text{ V}$ produces a current $I = 3 \text{ } \mu\text{A}$. The mobilities of air ions are $\mu_+ = 1.37 \text{ cm}^2 \text{ V}^{-1} \text{ s}^{-1}$, $\mu_- = 1.91 \text{ cm}^2 \text{ V}^{-1} \text{ s}^{-1}$.

Solution.

The mobility of an ion is the drift velocity acquired in unit electric field, i.e., $v_d = \mu E$. If n_+ be the concentration of positive ions and n_- that of negative ions, then $n_+ = n_-$.

$$j_+ = \text{current density due to } + \text{ ions} = v_d^+ n_+ e \\ = (\mu_+ E) n_+ e$$

$$j_- = \text{current density due to } - \text{ ions} = v_d^- n_- e \\ = \mu_- E n_- e$$

$$\therefore I \text{ (total current)} = S(j_+ + j_-) = SeE(\mu_+ n_+ + \mu_- n_-)$$

$$\Rightarrow I = SneE(\mu_+ + \mu_-) \quad (\because n_+ = n_- = n)$$

$$\Rightarrow I = SneV(\mu_+ + \mu_-)/d$$

$$\Rightarrow n = \frac{Id}{S(\mu_+ + \mu_-)eV}$$

Here

$$n = \frac{3 \times 10^{-6} \times 2 \times 10^{-2}}{500 \times 10^{-4} (1.37 + 1.91) \times 10^{-4} \times 1.6 \times 10^{-19} \times 100} \\ = 2.3 \times 10^{14} \text{ m}^{-3}$$

6. RESISTANCE

(a) The property of a conductor due to which it opposes the flow of current through it is called its electrical resistance.

(b) This property exists not only in metals but also in electrolytes, semiconductors etc.

(c) In case of metals obstruction in the drifting of free electrons (by metal lattice) gives rise to resistance.

Ohm's Law

If there is no change in the physical state (such as temperature etc) of a conductor, magnitude of

current is directly proportional to applied potential difference.

$$\text{i.e. } V \propto I$$

$$V = RI$$

Where R is a constant called 'Electrical Resistance' of the conductor

PROOF

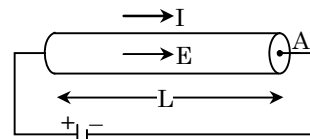

We know that

$$I = nev_d A \text{ and } v_d = \frac{eE}{m} \tau = \frac{eV}{mL} \tau$$

$$\text{Thus } I = \frac{ne^2 \tau}{m} A \frac{V}{L}, \quad V = \left[\left(\frac{m}{ne^2 \tau} \right) \frac{L}{A} \right] I$$

Comparing it with $V = RI$,

we get resistance of a given conductor as

$$R = \left(\frac{m}{ne^2 \tau} \right) \frac{L}{A}$$

where, $m \rightarrow$ mass of electrons,

$e \rightarrow$ charge of electrons,

$n \rightarrow$ no. of free electrons per unit volume,

$L \rightarrow$ Length of the conductor

$A \rightarrow$ Area of cross section perpendicular to current flow

NOTE

(1) Differential form of ohm's law can be written as $\vec{J} = \frac{\vec{E}}{\rho}$; where $\rho = \frac{m}{ne^2 \tau}$ is known as resistivity of the conductor.

(2) This relation is extremely important from the point of view of JEE as a wide variety of questions can be framed on this formula.

(a) S.I unit of resistance (R) is ohm (Ω) and its dimension is $[M^1 L^2 T^{-3} A^{-2}]$.

(b) Since $\rho = R \frac{A}{L}$, hence S.I units of resistivity is ohm-meter ($\Omega\text{-m}$) and its dimension is $[ML^3 T^{-3} A^{-2}]$.

(c) The quantity $\left(\frac{1}{R} \right)$ is called conductance (G) of the conductor having unit mho or siemens.

(d) Similarly the quantity $\left(\frac{1}{\rho} \right)$ is called conductivity (σ) of the material having units mho/meter.

(e) Resistivity or conductivity depends only on nature of material and temperature. With rise of temperature resistivity increases and conductivity decreases.

◆ Important Points

- (a) A conducting device obeys ohm's law only if its physical state remains unchanged. In this case the graph between I and V is a straight line passing through origin ($\because V \propto I$). Such a conductor (e.g. metals, alloys etc) is called ohmic-conductor having resistance (R) equal to reciprocal of slope of I-V. curve (see figure)

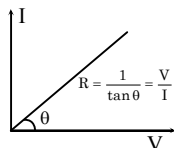

- (b) Resistance of ohmic conductor is independent of applied voltage hence it is also called **static resistance**.
- (c) For other substances such as gases, semiconductors, electrolytes etc, the I-V curve is not a straight line. Hence they are called nonohmic conductors. (see figure)

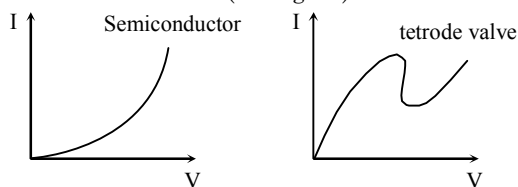

- (d) For non ohmic conductors it is not possible to determine static resistance (R) as the curve has different slopes at different voltage.
- (e) Therefore for these we define **dynamic resistance** (r) as ratio of change in voltage to change in current at a given voltage. It is also measured in ohm.

$$r = \frac{\Delta V}{\Delta I}$$

- (f) Remember that static resistance R can never be negative, but dynamic resistance r may have negative value (as in case of tetrode valve)

◆ Factors Affecting Resistance of Metals & Alloys

We know that

$$R = \frac{m}{ne^2\tau} \cdot \frac{\ell}{A}, \quad \tau = \frac{\lambda}{v_{rms}} \quad \text{and} \quad v_{rms} = \sqrt{\frac{3kT}{m}}$$

Hence we can conclude that resistance of a given metallic / alloy conductor, depends upon :

- (a) Length of conductor ($\because R \propto L$)
- (b) Area of cross section ($\because R \propto \frac{1}{A} \propto \frac{1}{r^2}$)
- (c) Nature of material ($\because R \propto \frac{1}{n}$)
- (d) Temperature ($R \propto \frac{1}{\tau}$ and $\tau \propto \frac{1}{\sqrt{T}}$)

Greater the temperature, lesser will be relaxation time hence greater will be resistance.

NOTE (1) In some text books resistance is

$$\text{derived as } R = \frac{ne^2\tau}{2m} \frac{\ell}{A} \text{ and not as}$$

given above. Students are advised not be confused or worried, as it does not affect the proportionality relationship of n , L , A and τ . with the resistance.

- (2) While determining the resistance of a conductor one should be careful while choosing area of cross section. Only the faces lying perpendicular to the flow of current should be selected. [see example 9 and 10]

Example Based on

Resistance

Example. 9

As shown in the figure resistivity of the material of the block is ρ . Find resistance of the block when battery is connected between

- (a) Faces ABCDA and EFGHE and
(b) Faces CBFGC and ADHEA.

Solution.

- (a) In this case area of cross section of the face lying perpendicular to current is bc , while the length is a , hence

$$R = \rho \frac{L}{A} = \frac{\rho a}{bc}$$

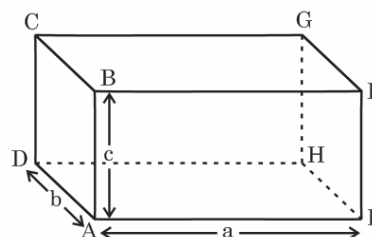

- (b) Similarly $A = ab$ and $L = c$.

$$\text{Thus } R = \rho \frac{c}{ab}$$

Example. 10

A cylindrical tube of length L has inner radius a and outer radius b as shown in the figure. What is the resistance of the tube between (a) its ends (b) its inner and outer surface. [resistivity of its material is ρ].

Solution.

- (a) In case of electrical conduction, field at a point inside a conductor is given by -

$$J = \sigma E$$

$$\text{i.e., } E = \rho J \quad [\text{as } \sigma = (1/\rho)] \quad \dots (1)$$

As here the current and field are along the axis of the tube, consider the tube to be made up of large number of coaxial annular disc and considering a disc of thickness dx at distance x from one end as shown in fig. We have.

$$E = -\frac{dV}{dx} \text{ and } J = \frac{I}{\pi(b^2 - a^2)} \text{ [as } S = \pi(b^2 - a^2)\text{]}$$

So eqn. (1) reduces to -

$$-\frac{dV}{dx} = \rho \frac{I}{\pi(b^2 - a^2)}$$

$$\text{i.e., } -\int_{V_1}^{V_2} dV = \int_0^L \frac{\rho I dx}{\pi(b^2 - a^2)}$$

$$\text{or } V = (V_1 - V_2) = \frac{\rho LI}{\pi(b^2 - a^2)}$$

$$\text{so } R = \frac{V}{I} = \frac{\rho L}{\pi(b^2 - a^2)}$$

Ans.

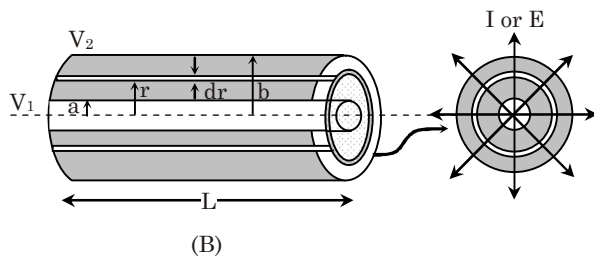
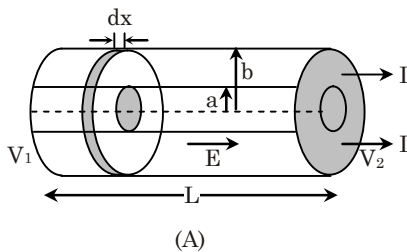

(b) As here the field is radial, consider the tube to be made up of large number of concentric cylindrical shells and considering a shell of radius r and thickness dr as shown in fig. we have

$$E = -\frac{dV}{dr} \text{ and } J = \frac{I}{2\pi rL}$$

[as here $S = 2\pi rL$]

So eqn. (1) for this case becomes -

$$-\frac{dV}{dr} = \frac{\rho I}{2\pi rL}$$

$$\text{i.e., } -\int_{V_1}^{V_2} dV = \int_a^b \frac{\rho I dr}{2\pi rL}$$

$$\text{or } V = (V_1 - V_2) = \frac{\rho I}{2\pi L} \log_e \left[\frac{b}{a} \right]$$

$$\text{so } R = \frac{V}{I} = \frac{\rho}{2\pi L} \log_e \left[\frac{b}{a} \right]$$

Ans.

◆ Important Results

(a) Effect of stretching a wire on its resistance.

(i) If the length of wire is changed.

$$\frac{R_1}{R_2} = \frac{\ell_1^2}{\ell_2^2} \text{ as mass remains unchanged } (\ell_1 A_1 = \ell_2 A_2)$$

(ii) If the radius of wire is changed.

$$\frac{R_1}{R_2} = \frac{r_2^4}{r_1^4}$$

(b) If a conductor is stretched to n times its original length its new resistance will be n^2 times the original value.

(c) If a conductor is stretched such that its radius is reduced to $1/n^{\text{th}}$ of its original value, its new resistance will be increased n^4 times.

(d) **Effect of Percentage Change in Length**

Consider a cylindrical wire of length L , area of cross section $A (= \pi r^2)$. If mass and density of wire are m and d then, its resistance would be.

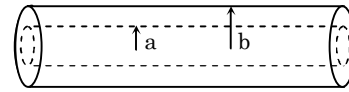

$$R = \rho \frac{\ell}{A} \text{ [}\rho = \text{resistivity of material]}$$

$$R = \frac{\rho d}{m} \ell^2 \quad [\because A \ell d = \text{mass of wire}]$$

$$R = k \cdot \ell^2 \quad \left[\frac{\rho d}{m} = \text{constt.} \right]$$

$$\frac{R_2}{R_1} = \frac{\ell_2^2 \left[1 + \frac{x}{100} \right]}{\ell_1^2}$$

$$\left[\begin{array}{l} \ell_1 = \ell \\ \ell_2 = x\% \text{ more than } \ell = \ell \left[1 + \frac{x}{100} \right] \end{array} \right]$$

Therefore Percentage change in resistance

$$\frac{R_2 - R_1}{R_1} \times 100 = \frac{\left[1 + \frac{x}{100} \right]^2 - 1}{1} \times 100 \approx 2x\%$$

[apply binomial theorem]

NOTE We can conclude that if wire is stretched to increase its length by $x\%$ then its resistance increases by $2x\%$. However this is true only when $x < 5\%$. However if percentage change in the length is more than 5% then the student is advised not to take binomial approximation. [see example 11(a) & (b)]

Example Based on
Change of resistance

Example. 11

Calculate the percentage change in the resistance of a conducting wire if it is stretched to increase its length by (a) 0.1 % & (b) 20%

Solution.

(a) As explained above (put $x = 0.1$) percentage change in resistance

$$= \frac{R_2 - R_1}{R_1} \times 100 \%$$

$$= \left\{ \left[1 + \frac{0.1}{100} \right]^2 - 1 \right\} \times 100 \approx 0.2\%$$

(b) Percentage Change

$$R = \left\{ \left(1 + \frac{20}{100} \right)^2 - 1 \right\} \times 100 \text{ put } x = 20$$

$$= \{(1.2)^2 - 1\} \times 100 = [1.44 - 1] \times 100 = 44 \%$$

Note that since percentage change in length is 20% then percentage increase in resistance is not 40 % but 44 %.

Example. 12

If resistance of a wire formed by 1 cc of copper be 2.46 Ω . The diameter of wire is 0.32 mm, then the specific resistance of wire will be -

- (A) 1.59×10^{-6} ohm. cm (B) 2.32×10^{-6} ohm. cm
(C) 3.59×10^{-6} ohm. cm (D) 1.59×10^{-8} ohm. cm

Solution. (A)

$$\text{length of wire} = \frac{(\text{volume})}{(\text{Area})} = \frac{1}{3.14 \times (0.016)^2}$$

$$\rho = \frac{RA}{\ell} = \frac{(2.46)3.14 \times (0.016)^2}{\left(\frac{1}{3.14 \times (0.016)^2} \right)} = 1.59 \times 10^{-6} \text{ ohm. cm}$$

ρ will be same for any shape of wire formed by metal.

Example. 13

A given piece of wire of length ℓ , cross sectional area A and resistance R is stretched uniformly to a wire of length 2ℓ . The new resistance will be -

- (A) 2R (B) 4R
(C) R/2 (D) Remains unchanged

Solution. (B)

$$R = \frac{\rho \ell}{A} \text{ and } R' = \frac{\rho(2\ell)}{A'}$$

ρ = specific resistance.

$$\therefore \frac{R'}{R} = \left(\frac{2\ell}{\ell} \right) \left(\frac{A}{A'} \right)$$

Further $A\ell = A'(2\ell)$ [Volume remains conserved]

$$\Rightarrow A/A' = 2$$

$$\therefore \frac{R'}{R} = 4 \text{ or } R' = 4R$$

Example. 14

A given piece of wire of length ℓ , radius r and resistance R is stretched uniformly to a wire of radius $(r/2)$. The new resistances will be -

- (A) 2R (B) 4R (C) 8R (D) 16R

Solution. (D)

The volume of given wire remains unchanged, hence

$$A\ell = A'\ell' \text{ or } (A/A) = (\ell/\ell')$$

$$R = \rho \frac{\ell}{A} \text{ and } R' = \frac{\rho \ell'}{A'}$$

$$\therefore \frac{R'}{R} = \frac{A}{A'} \frac{\ell}{\ell'} = \left(\frac{A}{A'} \right)^2$$

$$\therefore \frac{R'}{R} = \left(\frac{\pi r^2}{\pi r'^2} \right)^2 = 16 \quad [\because r' = \frac{r}{2}]$$

$$\Rightarrow R' = 16R$$

Example. 15

The resistance of wire is 50π then the graph between $\log V$ and $\log I$ is -

- (A) straight line passing through origin
(B) parabola
(C) hyperbola
(D) none of the above.

Solution. (D)

$$V = IR \Rightarrow \log V = \log I + \log R$$

This is a straight line but not passing through origin.

Example. 16

The current voltage graph for a given metallic wire at two different temperatures T_1 and T_2 are shown in fig. Which is true -

- (A) $T_1 = T_2$ (B) $T_1 > T_2$
(C) $T_1 < T_2$ (D) None of the above.

Solution. (C)

The slope of I - V curve

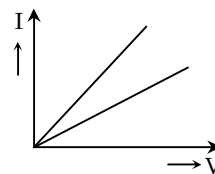

$$\frac{1}{V} = \frac{1}{R}$$

i.e. slope $\propto \frac{1}{R}$

The slope of graph at temperature T_1 is greater than that at temperature T_2 .

\therefore Resistance at $T_2 >$ Resistance at T_1

For metallic wire the resistance R increases with increase of temperature.

Hence $T_2 > T_1$.

◆ Temperature Dependence of Resistance and Resistivity

(a) We have discussed earlier that resistance as well as resistivity changes with change in temperature. This variation can be explained on the basis of temperature coefficient of resistance (or resistivity).

(b) The temperature coefficient of resistance is defined as fractional change in resistance per unit rise of temperature. It is denoted by α and is measured in $^{\circ}\text{C}^{-1}$ or K^{-1} .

$$\alpha = \frac{\Delta R}{R} \times \frac{1}{\Delta \theta}, \text{ therefore}$$

$$\Delta R = R \alpha \Delta \theta.$$

If R_t and R_0 are resistance of a conductor at $t^{\circ}\text{C}$ and 0°C respectively then

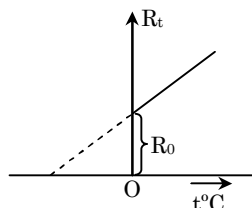

$$R_t - R_0 = R_0 \alpha (t - 0)$$

$$R_t = R_0 [1 + \alpha t]$$

where α = coefficient at 0°C .

If temperature coefficient of resistance at $t_1^{\circ}\text{C}$ is α and resistance is R_1 then resistance at any other temp. t_2 will be.

$$R_2 = R_1 [1 + \alpha (t_2 - t_1)]$$

From the above discussion it is clear that.

(i) resistance changes linearly with temperature provided α is constant.

This can be represented graphically as -

(ii) $\alpha_{\text{metals}} = + \text{ve}$

$\alpha_{\text{alloys}} = 0$

$\alpha_{\text{electrolyte}} = - \text{ve}$

(c) The temperature coefficient of resistivity changes with temperature as

$$\rho = \rho_0 [1 + \alpha \Delta \theta + \beta (\Delta \theta)^2 + \dots]$$

where α & β are called temperature coefficients of resistivity.

$$\text{If } \Delta \theta \text{ is small } \rho = \rho_0 [1 + \alpha \Delta \theta]$$

(d) The general relationship can be represented graphically as :

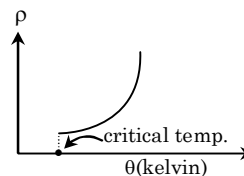

(e) The graph shows that at critical temperature the resistivity absolutely falls to zero. This phenomenon is known as **super-conductivity**.

Example Based on

Effect of temperature

Example. 17

Resistivity and temperature coefficient of resistivity of a material at a temperature T_0 is ρ_0 and α respectively. Prove that resistivity of the conductor at the temperature T would be $\rho = \rho_0 [1 + \alpha (T - T_0)]$, provided the quantity $T - T_0$ is small. Assume α remains constant during the temp range.

Solution.

By definition of temperature coefficient of resistivity.

$$\frac{d\rho}{\rho dT} = \alpha \Rightarrow \int_{\rho_0}^{\rho} \frac{d\rho}{\rho} = \int_{T_0}^T \alpha dT$$

$$\ln\left(\frac{\rho}{\rho_0}\right) = \alpha (T - T_0)$$

$$\rho = \rho_0 e^{\alpha(T-T_0)}$$

$$\text{Using expansion of } e^x = 1 + \frac{x}{1!} + \frac{x^2}{2!} + \frac{x^3}{3!} + \dots$$

Where $x = T - T_0$, since $T - T_0$ is small, we can neglect higher terms.

$$\text{Therefore } e^{\alpha(T-T_0)} = 1 + \alpha (T - T_0)$$

$$\text{Hence } \rho = \rho_0 [1 + \alpha (T - T_0)]$$

Example Based on

Temperature coefficient

Example. 18

The temperature coefficient of resistance of a conductor at 0°C is $0.0125 / ^{\circ}\text{C}$. If its resistance at 300 K is R , at what temperature it will rise to $2R$?

Solution.

Wrong Method :

Given $\alpha = 0.0125 ^{\circ}\text{C}^{-1}$ at 0°C temp.

$$T_1 = 300 \text{ K} = 27^{\circ}\text{C} \quad R_1 = R$$

$$T_2 = ? \quad R_2 = 2R$$

$$R_2 = R_1 [1 + \alpha (T_2 - T_1)]$$

$$2R = R [1 + 0.0125 (T_2 - 27)]$$

solving this we get

$$t_2 = 107^{\circ}\text{C} = 380 \text{ K}.$$

This is not a proper method, as the **correct formula** is

$$R_t = R_0 [1 + \alpha (t - 0)]$$

where R_0 = resistance at 0°C .

Correct Method :

$$R_2 = R_0 [1 + \alpha (t_2 - 0)]$$

$$2R = R_0 [1 + 0.0125 (t_2)] \quad \dots(1)$$

$$R_1 = R_0 [1 + 0.0125 (t_1)]$$

$$R = R_0 [1 + 0.0125 (t_1)] \quad \dots(2)$$

$$\text{By (1) \& (2) } \frac{R}{2R} = \frac{R_0[1 + 0.0125 t_1]}{R_0[1 + 0.0125 t_2]}$$

put $t_1 = 27^\circ\text{C}$ in this we get

$$\Rightarrow t_2 = 134^\circ\text{C} = 407\text{K}$$

NOTE However if in a numerical problem, nothing is mentioned about temperature at which α is given then the formula $R_2 = R_1 [1 + \alpha(t_2 - t_1)]$ can be used. The answer arrived at would be approximately correct.

Example. 19

At any temperature $t^\circ\text{C}$, two resistances R_1 and R_2 have temperature coefficients α_1 & α_2 respectively. Find equivalent temperature coefficient of their resultant if they are connected in -

- (a) series and (b) parallel.

Assume α_1 and α_2 remain constant with temperature.

Solution.

(a) In series combination

$$\text{At } t_1^\circ\text{C, } R = R_1 + R_2$$

$$\text{At } t_2^\circ\text{C } R' = R_1' + R_2'$$

$$= R_1 [1 + \alpha_1 (t_2 - t_1)] + R_2 [1 + \alpha_2 (t_2 - t_1)]$$

$$= R_1 + R_2 + (R_1\alpha_1 + R_2\alpha_2) (t_2 - t_1)$$

If temperature coefficient of the series equivalent is α_s then

$$R' = R [1 + \alpha_s (t_2 - t_1)] = (R_1 + R_2) [1 + \alpha_s (t_2 - t_1)] \text{ or, } R_1 + R_2 + (R_1\alpha_1 + R_2\alpha_2) (t_2 - t_1)$$

$$= R_1 + R_2 + (R_1 + R_2) \alpha_s (t_2 - t_1)$$

$$\alpha_s = \frac{R_1\alpha_1 + R_2\alpha_2}{R_1 + R_2} \quad \text{Ans.}$$

(b) In parallel combination

$$\text{At } t_1^\circ\text{C, } R = \frac{R_1 R_2}{R_1 + R_2}$$

$$\text{At } t_2^\circ\text{C, } R' = \frac{R_1' R_2'}{R_1' + R_2'}$$

$$= \frac{R_1[1 + \alpha_1(t_2 - t_1)] R_2[1 + \alpha_2(t_2 - t_1)]}{R_1 + R_2 + (R_1\alpha_1 + R_2\alpha_2)(t_2 - t_1)} \quad \dots(1)$$

If temperature coefficient of the parallel equivalent is α_p , then

$$R' = R [1 + \alpha_p (t_2 - t_1)] \quad \dots(2)$$

$$\text{where } R = \frac{R_1 R_2}{R_1 + R_2}$$

from eq (1) and (2)

$$\frac{R_1 R_2 [1 + \alpha_p \Delta t]}{R_1 + R_2} = \frac{R_1 R_2 [1 + \alpha_1 \Delta t][1 + \alpha_2 \Delta t]}{R_1 + R_2 \left[1 + \frac{R_1 \alpha_1 + R_2 \alpha_2}{R_1 + R_2} \Delta t \right]}$$

put $t_2 - t_1 = \Delta t$

$$1 + \alpha_p \Delta t = \frac{[1 + (\alpha_1 + \alpha_2) \Delta t + \alpha_1 \cdot \alpha_2 \cdot \Delta t^2]}{1 + \frac{R_1 \alpha_1 + R_2 \alpha_2}{R_1 + R_2} \Delta t},$$

cancelling the term $(\alpha_1 \cdot \alpha_2 \Delta t^2)$ we get

$$1 + \alpha_p \Delta t = \frac{1 + (\alpha_1 + \alpha_2) \Delta t}{1 + \frac{R_1 \alpha_1 + R_2 \alpha_2}{R_1 + R_2} \Delta t}$$

$$1 + \alpha_p \Delta t + \frac{(R_1 \alpha_1 + R_2 \alpha_2) \Delta t}{R_1 + R_2} + \left[\frac{R_1 \alpha_1 + R_2 \alpha_2}{R_1 + R_2} \right] \alpha_p \Delta t^2 = 1 + (\alpha_1 + \alpha_2) \Delta t$$

Again cancelling the higher product term, we get.

$$1 + \alpha_p \Delta t + \frac{(R_1 \alpha_1 + R_2 \alpha_2) \Delta t}{R_1 + R_2} = 1 + (\alpha_1 + \alpha_2) \Delta t$$

therefore

$$\alpha_p \Delta t = \left[\alpha_1 + \alpha_2 - \frac{R_1 \alpha_1 + R_2 \alpha_2}{R_1 + R_2} \right] \Delta t$$

$$\Rightarrow \alpha_p = \frac{R_1 \alpha_2 + R_2 \alpha_1}{R_1 + R_2}$$

Example Based on

Miscellaneous

Example. 20

Two identical metallic balls of radius a are placed in a homogeneous poorly conducting medium with resistivity ρ . Find the resistance of the medium between the balls, under the condition that the distance between them is much larger than their size.

Solution.

Let us impart (mentally) charges $+q$ and $-q$ to the balls. Since the balls are at a large distance from one another, electric field near the surface of each ball is partially determined only by the charge of the nearest sphere and its charge can be considered to be uniformly distributed over the surface.

Surrounding the positively charged ball by a concentric sphere adjoining directly the ball's surface, we write the expression for the current through this sphere as.

$$i = 4\pi a^2 j$$

where j is current density

From ohm's law

$$J = \frac{E}{\rho}$$

where $E = \frac{1}{4\pi\epsilon_0} \frac{q}{a^2}$

$$i = 4\pi a^2 j = 4\pi a^2 \frac{E}{\rho} = 4\pi a^2 \frac{q}{4\pi\epsilon_0} \frac{1}{a^2} \frac{1}{\rho} = \frac{q}{\epsilon_0\rho}$$

If the potential difference between the balls is V, then

$$V = V_+ - V_- = \frac{+q}{4\pi\epsilon_0 a} - \frac{-q}{4\pi\epsilon_0 a} = \frac{2q}{4\pi\epsilon_0 a}, \text{ but from}$$

ohm's law $R = \frac{V}{I} = \frac{\rho}{2\pi a}$

7. CELL OR SOURCE OF EMF

- (a) It is a device which converts other forms of energy into electrical energy. There are various types of sources of emf available – electrochemical cell, solar cell, thermoelectric couple, dynamo, etc. However we will confine our discussion to electrochemical cell only and in this chapter, the term cell is used to refer to electrochemical cell (ECC).
- (b) An ECC converts chemical energy into electrical form. The main purpose of a cell is to maintain potential difference across the ends of a circuit or circuit element. This ensures flow of steady state current (direct current).
- (c) A cell has two electrodes of different materials which are dipped in electrolyte solution. Due to electrochemical reactions positive charge accumulates at the electrode called anode, while negative charge at the cathode.

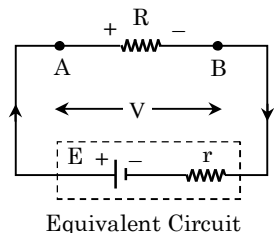
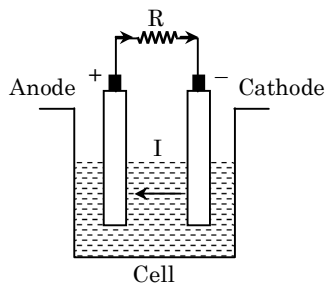

- (d) When an external resistance (or load) is connected between the electrodes + ve charge flows from anode to cathode in the external resistance. However as charge is conserved, it

must flow from cathode to anode in the internal circuit of the cell.

- (e) The internal circuit current flows as +ve and –ve ions. But in the external circuit it depends on the circuit element. (metal, semi conductor or gas etc.)

◆ Cell Terminology

(a) Electromotive force : (EMF) :

It refers to the work done by the cell in moving unit + ve charge in the whole circuit including the cell once. So $E = \frac{W}{q}$

- (i) It is measured in joule / coulomb or volt.
- (ii) The emf of a cell depends only on the nature of electrodes and electrolyte and is constant for a given electrode electrolyte combination, e.g. for Lechlanche cell emf is 1.45 while emf of dry cell is 1.5 V. It is independent of size and shape of the cell.
- (iii) If a cell is connected in a circuit such that current flows from anode to cathode then its emf is considered to be positive, otherwise negative. (see figure)

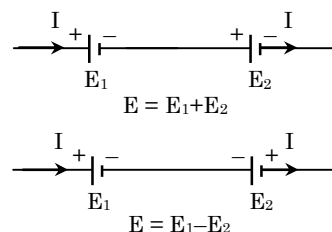

(b) Potential Difference : (V)

- (i) In reference to an electric circuit potential difference between any two points is defined as the work done in moving unit + ve charge from one point to the other point of the circuit. It is equal to the product of resistance R between the two points and current (I) flowing through it.

i. e., $V = IR$

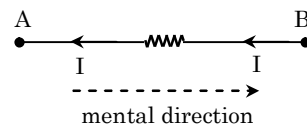
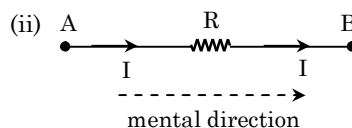

While calculating potential difference between two points say A and B we travel mentally in any direction. If the current flows in the direction of travel then the products is considered positive (+ IR). If current flows opposite to the direction of travel then it is taken negative (– IR). As shown above.

$$V_A - IR = V_B$$

$$\Rightarrow V_A - V_B = IR$$

[I flows along mental direction]

$$V_A + IR = V_B$$

$$\Rightarrow V_A - V_B = -IR$$

[I flows opposite to mental direction]

(c) Internal resistance (r) :

- (i) Internal resistance of a cell depends on the distance between electrodes ($r \propto d$) area of electrodes $\left(r \propto \frac{1}{A} \right)$ concentration of electrolyte ($r \propto c$) and its temp $\left(r \propto \frac{1}{T} \right)$.

NOTE If two cells are of same emf, the internal resistance of reversible (secondary) cell is lower than that of irreversible (primary) cell.

- (ii) The internal resistance of an ideal cell is zero. But for real cell it is non-zero and is always connected in series with the cell.

(d) Relation between E, V and r

If a resistance R is connected between the terminals of a cell of emf E and internal resistance r (see fig.) the current in the circuit by ohm's law will be

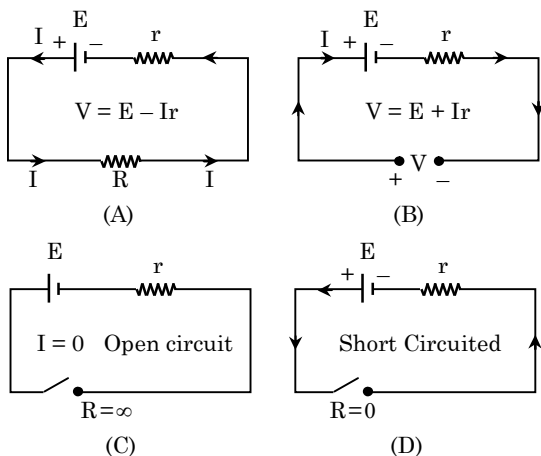

$$I = \frac{E}{R + r} \quad \text{or} \quad E = IR + Ir$$

Here the quantity IR is called terminal voltage (V) and Ir is called internal drop (X). Therefore

$$E = V + X$$

$$\frac{E}{V} = 1 + \frac{X}{V} = \left[1 + \frac{r}{R} \right] \Rightarrow r = R \left[\frac{E}{V} - 1 \right]$$

From this expression it is clear that :

- (i) **If the cell is ideal** ($r = 0$), then $E = V$
i.e. for ideal cell the terminal voltage is equal to the emf of the cell.

- (ii) **When the cell is discharging** or when current is drawn from the cell then (see fig. A)

$$E = V + X$$

$$V = E - X$$

$$V = E - Ir \Rightarrow V < E \quad (\text{if } I \neq 0, r \neq 0)$$

i.e. for a real discharging cell the terminal voltage must be lesser than its e.m.f.

When the cell (reversible) is charging or when current is flowing into the cell (see fig B)

$$V = E + X$$

$$V = E + Ir \Rightarrow V > E \quad (\text{if } I \neq 0, r \neq 0)$$

i.e. when a real cell is being charged the terminal voltage must be greater than the emf of the cell.

- (iii) **When the cell is in open circuit** or when external resistance is infinite ($R = \infty$) then, (see fig. C)

$$I = \frac{E}{(r + \infty)} = 0 \quad \text{so} \quad V = E - Ir = E$$

Thus when a real cell is in open circuit no current flows in the circuit and hence terminal voltage of cell is equal to its emf.

- (iv) **When the cell is short circuited** or when external resistance is zero ($R = 0$), then, (see fig. D)

$$I = \frac{E}{(0 + r)} = \frac{E}{r} = \text{max.}$$

$$V = I \times 0 = 0$$

When a real cell is short circuited the current drawn from cell is maximum & terminal voltage is zero.

- (v) **When the cell has become old :** In this case the internal resistance of the cell increases and its emf decreases. This is why a fresh cell gives more current as compared to old one.

- (vi) **Current capacity :** Current capacity of a cell depends upon the amount of electrolyte. A bigger cell contains more electrolyte and so has greater capacity than a smaller one.

Current capacity is measured in ampere hour.

◆ **Power Transfer**

It is defined as the time rate of energy transferred by a cell to the load. It is given by

$$W = qV$$

$$W = I^2 R t \quad [q = It, \text{ \& } V = IR]$$

therefore $\frac{W}{t} = P = I^2 r$

$$\Rightarrow P = \frac{E^2 R}{(R + r)^2} \quad [\because I = \frac{E}{R + r}]$$

From the equations it is clear that power transferred to the load will be maximum when

$$\frac{dP}{dR} = 0$$

$$\frac{d}{dR} \left[\frac{E^2 R}{(R + r)^2} \right] = 0$$

on solving it we get $R = r$.

This shows that power transferred by a cell to the load will be maximum when external load is equal to internal resistance of the cell, i.e. $R = r$. This rule is known as **maximum power transfer theorem** and the power transferred to the load (R) in this condition is

$$P_{\max} = \frac{E^2 R}{(R + r)^2} = \frac{E^2}{4r}$$

NOTE It is common misconception that "current will be maximum when power consumed by the load is maximum".

$$\text{Actually, } I_{\max} = \frac{E}{0 + r},$$

when $R = 0$ and not when $R = r$

Example Based on Cell

Example. 21

A battery of emf 2V and $r = 0.1 \Omega$ is being charged with a current of 5 ampere. In what direction will the current flow inside the battery? What is the terminal voltage between two terminals of the battery?

Solution.

In charging a battery (reversible) current inside should flow from anode to cathode (see figure)

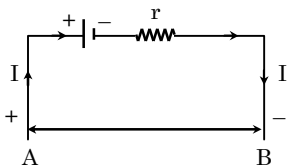

From figure we can say

$$V_A + E + Ir = V_B$$

$$|V_A - V_B| = E + Ir = 2 + 5 \times 0.1$$

$$|V_A - V_B| = 2.5 \text{ V}$$

Example. 22

An accumulator is first connected to load R_1 , and then to another load R_2 for the same time. In both cases the time rate of heat generation across the loads is same. Calculate internal resistance of the accumulator.

Solution.

According given problem $\frac{H_1}{t} = \frac{H_2}{t}$

$$\frac{E^2 R_1}{(R_1 + r)^2} = \frac{E^2 R_2}{(R_2 + r)^2},$$

solving it we get $r = \sqrt{R_1 R_2}$

Example. 23

Two batteries of same emf E but different internal resistance r_1 and r_2 ($< r_1$) are connected in series to an external resistance R .

(a) Find value of R that makes potential difference zero across the terminals of one battery.

(b) Which battery is it?

Solution.

As both the batteries are being discharged, current drawn

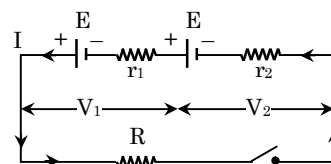

$$I = \frac{E + E}{R + r_1 + r_2} = \left[\frac{\text{Total emf}}{\text{Total resistance}} \right] \quad \dots(1)$$

$$\text{Also } V_1 = E - Ir_1 \text{ and } V_2 = E - Ir_2$$

$$\text{But as } r_1 > r_2 \Rightarrow V_1 < V_2$$

So if potential difference across any one of the batteries is to become zero it should be V_1 (i.e. across the one which has higher internal resistance).

$$V_1 = E - Ir_2 = 0$$

$$\Rightarrow I = \frac{E}{r_2} \quad \dots(2)$$

Hence from eq. (1) and (2)

$$\frac{2E}{R + r_1 + r_2} = \frac{E}{r_2} \Rightarrow R = r_1 - r_2$$

Example. 24

What is the potential difference between the points M and N for the circuit shown below.

Solution.

As +ve terminals of both cells are connected at junction C, therefore the cell $E_1 = 12\text{V}$ will discharge while the cell $E_2 = 6\text{V}$ will be charged. Hence the current flow will follow the loop ACDBA or

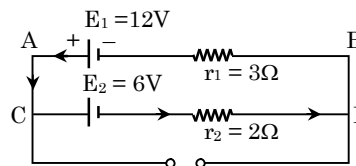

$$I = \frac{|E_1 - E_2|}{r_1 + r_2} = \frac{12 - 6}{3 + 2} = 1.2\text{A}$$

For the cell E_1 (which is being discharged)

$$V_A - V_B = E_1 - Ir_1 = 12 - 1.2 \times 3 = 12 - 3.6 = 8.4 \text{ V}$$

Similar for the cell E_2 (which is being charged)

$$V_C - V_D = E_2 + Ir_2 = 6 + 1.2 \times 2 = 8.4 \text{ V}$$

$$\text{So } V_A - V_B = V_C - V_D = V_M - V_N = 8.4 \text{ V}$$

8. CIRCUIT ANALYSIS

As mentioned in the preface of this booklet we have followed a very innovative and simplified approach towards circuit analysis. After a thorough study of all possible resistor, capacitor and inductor networks, we have grouped them in a certain number of categories as given below. There is a technique for solving a network falling in a particular category or sub category. As an aspirant of JEE you are advised to conduct a deep study of each group and its underlying principles there in.

Once you have mastered the techniques for solving each and every category the analysis of electrical circuits will become amazingly easy.

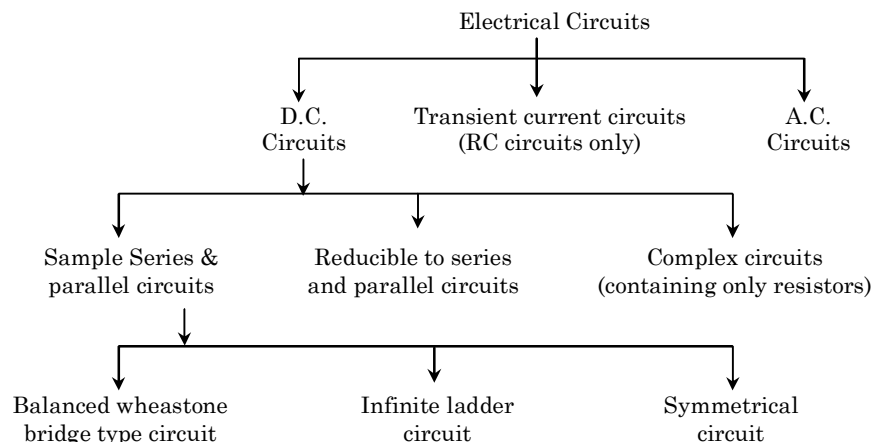

In this booklet we will not study A.C. circuits. It will be dealt in the chapters coming later.

Before going into details of each category let's first understand the principle behind grouping of resistances.

9. SIMPLE SERIES AND PARALLEL CIRCUITS

Replacing a combination of resistances by an equivalent resistance is called grouping of resistances. It is divided into three types namely series, parallel and mixed grouping.

◆ Resistances in 'Series'

(a) The principal of series combination can be remembered in the form of abbreviation CUPD.

(b) The term CUPD means "Current Undivided Potential difference Divided. This implies that in series combination of resistances current through each resistor flows undivided but the potential drop provided by the source is divided in direct proportion to the resistances ($V \propto R$)

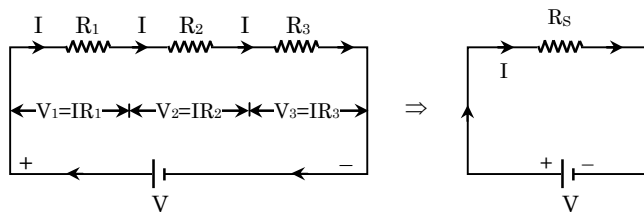

From the figure it is clear that

$$I = I_1 = I_2 = I_3 = \dots; \text{ and}$$

$$V_1 = IR_1, V_2 = IR_2 \text{ \& } V_3 = IR_3 \dots; \text{ and}$$

$$V = V_1 + V_2 + V_3 + \dots$$

If equivalent resistance is R_s then

$$V = IR_s$$

Therefore $R_s = R_1 + R_2 + R_3 + \dots$

(c) Since in series combination potential is divided according to $V \propto R$, hence is case of three resistors in series

$$V_1 : V_2 : V_3 = R_1 : R_2 : R_3 \text{ and } V = V_1 + V_2 + V_3$$

$$\text{i.e. } V_1 = \frac{R_1}{R_1 + R_2 + R_3} V \quad \text{and}$$

$$V_2 = \frac{R_2}{R_1 + R_2 + R_3} V \quad \text{and}$$

$$V_3 = \frac{R_3}{R_1 + R_2 + R_3} V$$

◆ Resistances in Parallel

(a) We can remember the principle of parallel combination in the abbreviated form PUCD - i.e. Potential Undivided & Current Divided.

- (b) This implies that in parallel combination potential difference across each resistance is same, but total current from the source is divided in the inverse proportion of the resistance $\left(I \propto \frac{1}{R} \right)$.

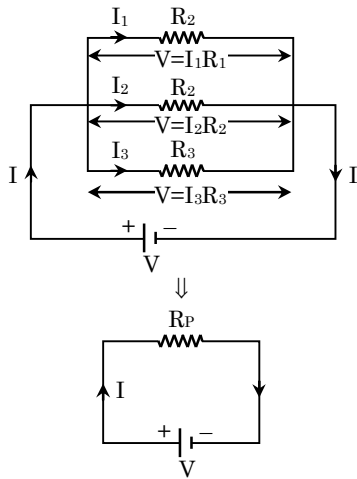

From the figure we can say that $V = V_1 = V_2 = V_3 = \dots\dots\dots$, and

$$I_1 = \frac{V}{R_1}, I_2 = \frac{V}{R_2}, I_3 = \frac{V}{R_3};$$

..... and $I = I_1 + I_2 + I_3 + \dots\dots\dots$

If equivalent resistance is R_p then $I = \frac{V}{R_p}$,

therefore $\frac{V}{R_p} = \frac{V_1}{R_1} + \frac{V_2}{R_2} + \frac{V_3}{R_3}$

$$\frac{1}{R_p} = \frac{1}{R_1} + \frac{1}{R_2} + \frac{1}{R_3} + \dots\dots\dots$$

- (c) In case of three resistance in parallel

$$I_1 : I_2 : I_3 = \frac{1}{R_1} : \frac{1}{R_2} : \frac{1}{R_3} \text{ and } I = I_1 + I_2 + I_3$$

Hence $I_1 = \frac{\frac{1/R_1}{1/R_1 + 1/R_2 + 1/R_3}}{I}$,

$$I_2 = \frac{\frac{1/R_2}{1/R_1 + 1/R_2 + 1/R_3}}{I}$$

and so on

NOTE (1) In case of parallel grouping the equivalent resistance is lower than the value of lowest resistance in the combination. If n resistance are connected in series and parallel respectively the ratio of their resultants will be $\frac{nR}{R/n} = n^2$.

- (2) While determining equivalent resistance of a circuit, one must select the terminals (or points) across which the equivalent resistance is to be calculated. This is because in a given network equivalent resistance would be different across different sets of terminals, e.g. as shown in the figure below equivalent resistance R_{AB} and R_{AD} will be different.

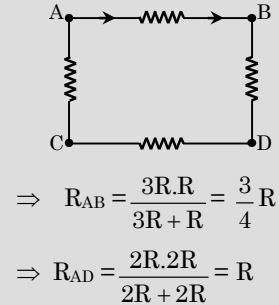

Example Based on Simple series and parallel circuits

Example. 25

Resistance $R, (R + 1), (R + 2) \dots\dots (R + n)$ are connected in series. Calculate equivalent resistance.

Solution.

As in series combination

$$R_s = R_1 + R_2 + R_3 + \dots\dots\dots R_n = R + (R + 1) + (R + 2) + \dots\dots\dots (R + n)$$

This is an arithmetic progression with

no. of terms = $n + 1$

first term $a = R$

common difference $d = 1$

$$\begin{aligned} \text{Therefore } R_s = S_n &= \frac{n}{2} [2a + (n - 1) d] \\ &= \frac{n+1}{2} [2R + \{2(n + 1) - 1\} 1] \\ &= \frac{n+1}{2} [2R + n] \end{aligned}$$

$$R_s = (n + 1) \left(R + \frac{n}{2} \right)$$

Example. 26

Resistances $R, 2R, 4R, 8R \dots\dots\dots \infty$ are connected in parallel. Calculate equivalent resistance.

Solution.

As in parallel combination

$$\begin{aligned} \frac{1}{R_p} &= \frac{1}{R_1} + \frac{1}{R_2} + \frac{1}{R_3} + \dots\dots\dots \infty \\ &= \frac{1}{R} + \frac{1}{2R} + \frac{1}{4R} + \frac{1}{8R} + \frac{1}{\infty} = \frac{1}{R} \left[1 + \frac{1}{2} + \frac{1}{4} + \frac{1}{8} + \dots\dots\dots 0 \right] \end{aligned}$$

(Geometric progression)

$$\frac{1}{R_p} = \frac{1}{R} \left[\frac{a}{1-r} \right] = \frac{1}{R} \left[\frac{1}{1-\frac{1}{2}} \right]$$

$$\therefore \frac{1}{R_p} = \frac{2}{R} \Rightarrow R_p = \frac{R}{2}$$

Example. 27

A wire of resistance 10Ω is bent to form a complete circle. Find the resistance between two diametrically opposite points (in Ω).

Solution.

As shown in the figure, the equivalent resistance between the points A & C (R_{AC}) is equivalent to parallel combination of arms ADC and ABC, each of which is equal to 5Ω .

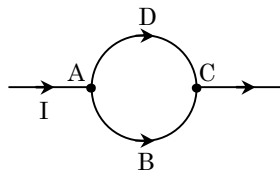

$$\text{Thus } R_{AC} = \frac{5 \times 5}{5 + 5} = 2.5 \Omega$$

Example. 28

Find the equivalent resistance and current supplied by the battery in the network given below.

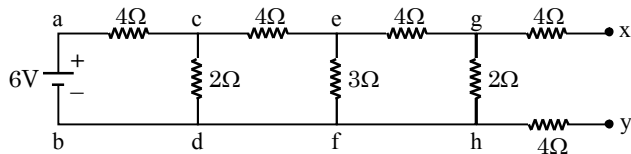

Solution.

To find the current supplied by the battery first we must calculate equivalent resistance. In such types of network the student must always start from the side lying farthest from the battery.

Note that no current shall flow through the resistances (g - x) and (h - y). Hence removing them from the network will not change its equivalent resistance. Thus, the network can be reduced in following steps.

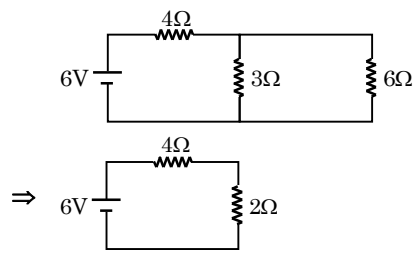
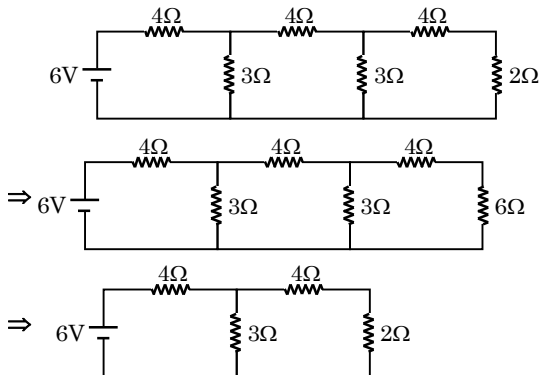

$$\therefore R_{eq} = 6\Omega$$

$$\text{and } I = \frac{V}{R_{eq}} = \frac{6}{6} = 1 \text{ A}$$

Example. 29

Two conductors AB and CD are connected between two parallel resistors in such a way that no current flow through them (see figure). Then a wire is connected between E and F. Explain whether any current flows between points E & F or not? If yes then explain the direction of current flow.

Solution.

As no current flows through the wire AB, thus every point of this wire must be at same potential (say V_E) similarly every point on the wire CD should also be at same potential (say V_F). But the direction of current in the network shows that wire AB must be at higher potential than wire CD. Thus $V_E > V_F$. Hence current should flow from point E to point F.

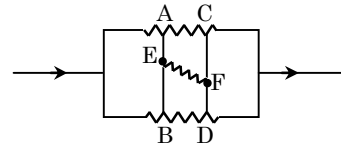

Example. 30

In the adjoining figure find the p.d. between the points A and B and the potential of point B. The point C is earthed.

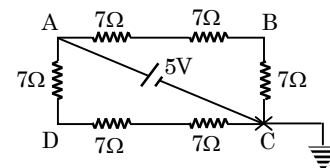

Solution.

(a) The arms ABC and ADC are connected parallel to each other.

Therefore

$$\frac{1}{R_{eq}} = \frac{1}{R_{ABC}} + \frac{1}{R_{ADC}}$$

$$R_{eq} = \frac{21 \times 21}{21 + 21} = \frac{21}{2} \Omega$$

So the current drawn from the cell

$$I = \frac{V}{R_{eq}} = \frac{5}{\frac{21}{2}} = \frac{10}{21} \text{ A.}$$

It will be divided equally between branches R_{ABC} and R_{ADC} hence current in the branches will be $\frac{5}{21}$ A each. (see figure).

Therefore from ohm's law

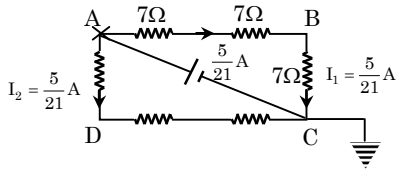

$$V_{AB} = I_1 (7\Omega + 7\Omega)$$

$$= \frac{5}{21} \times 14 \text{ volt} = \frac{10}{3} \text{ volt}$$

(b) Since the point C is earthed hence $V_C = 0$. Therefore from ohm's law

$$\frac{V_B - V_C}{R_{BC}} = I_1 = \frac{V_B - 0}{7\Omega} = \frac{5}{21} \text{ A}$$

$$V_B = \frac{5}{3} \text{ volt.}$$

10.NETWORKS REDUCIBLE TO SIMPLE SERIES AND PARALLEL CIRCUITS

There are a large number of networks which on first look, appear rather complicated. But on close observation we can reduce such networks into simple series & parallel circuits. In this chapter this category has been dealt, in three separate subcategories namely.

- Balanced Wheatstone bridge type circuits.
- Symmetrical circuits.
- Infinite circuits.

But before we go into details of each of these, let's first understand a very simple yet effective method of reducing complicated networks. It is known as **Point Potential Technique**.

◆ Point Potential Technique

This method is based on the fact that in an electrical circuit potential of every points is unique. Therefore if any two or more points are joined by connecting wire they will be at same potential and as such can be treated as a single point. This technique can be applied in following steps

- Assign number to each and every junction of a circuit.
- Identify all the junctions joined by zero resistance connecting wires. These junctions must be at same potential and can be treated as single point.
- Identify the terminals / points across which equivalent resistance is to be calculate.

Mark these points far away from each other. Note that a single point may represent more

than one junctions (if several junctions correspond to same potential). Now mark the remaining junctions as separate points.

- Rewrite the circuit an go on reducing it till final result is achieved.

Example Based on

Point potential technique

✎ Example. 31

From the figure given below determine net resistance a cross the junction A and B.

Solution.

Step (i) Mark each junction 1 to 5 as shown.

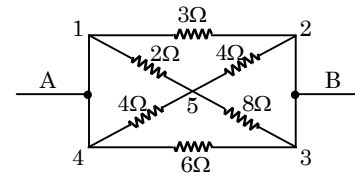

Step (ii) The junction groups (A, 1, 4) (2, B, 3) and (5) can be each treated as points as they are at same potentials. Mark these groups as points shown below.

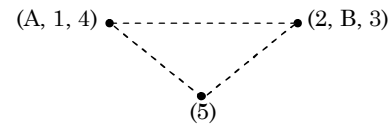

Step (iii) Now we can connect these points with corresponding junctions as shown.

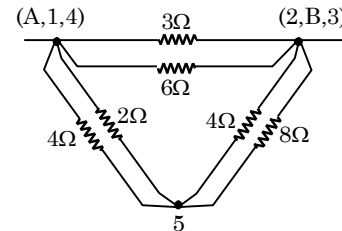

Step (iv) Reducing the network further we get.

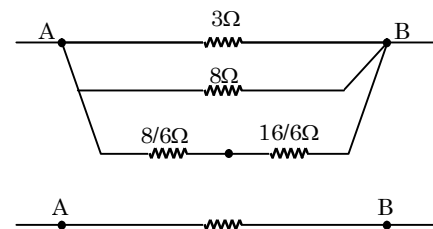

$$\frac{1}{R_{AB}} = \frac{1}{3} + \frac{1}{6} + \frac{6}{24}$$

$$\Rightarrow R_{AB} = \frac{24}{8 + 4 + 6} = \frac{24}{18} = \frac{4}{3} \Omega$$

Example. 32

Find the equivalent resistance across the points a & b for the networks shown in the figure.

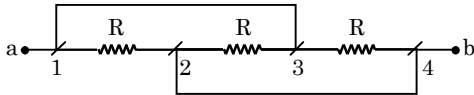

Solution.

The network given in figure can be reduced according to point potential technique in following steps

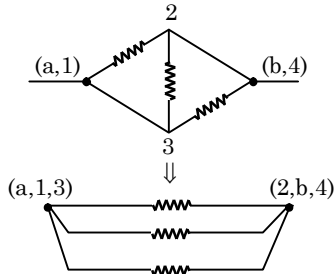

$$R_{ab} = R/3$$

Example. 33

The equivalent resistance of the network shown below (each resistor has value r) between the junctions A & E.

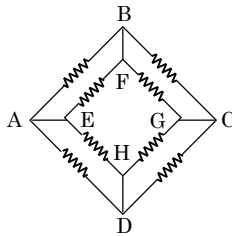

Solution.

This network can also be solved using Kirchoff's Laws. However we will solve it using point potential technique. Let's first connect the junctions A and E with (+) and (-) terminals of a battery. Also, we assume that a current of magnitude 3I enters the junction A. The division of this current is shown in the figure.

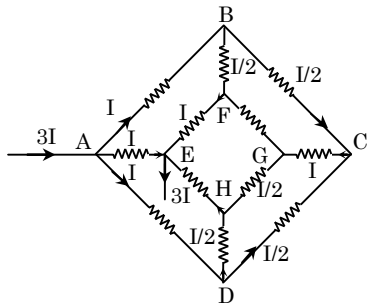

It become clear that potential drops

$$V_A - V_B = V_A - V_D = I r$$

$$\therefore V_B = V_D$$

Thus the junctions B and D can be treated as a single point. Similarly

$$V_E - V_F = V_E - V_H = \frac{I}{2} \cdot r.$$

$$V_F = V_H$$

The junctions F and H can also be treated as a single point.

Since R_{eq} is to be calculated between points. A and E, mark them far from each other. Rewrite the network using point potential technique as given below.

$$\text{Solving this network we will get } R_{AE} = \frac{7}{12} R$$

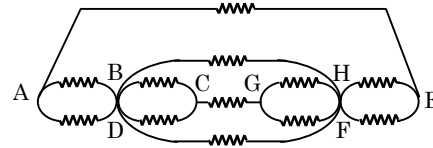

Balanced Wheatstone bridge type circuits

If in a network, resistance are arranged as in the circuit shown below, the network is called **balanced Wheatstone bridge** and is said to be balanced if $\frac{P}{Q} = \frac{R}{S}$

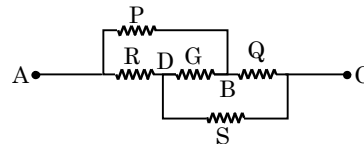
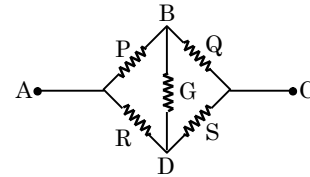
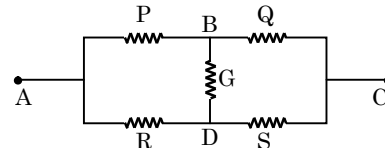

Details of Wheatstone bridge will be dealt later. Here it is sufficient to know that in a balanced Wheatstone bridge certain points are at same potential (see points B and D) and so no current flows through the resistor connected between such points (as the resistor G in above figures.) Therefore removing such resistors will have no effect on net resistance. Thus in a balanced Wheatstone bridge equivalent circuit resistance can be calculated as follows :

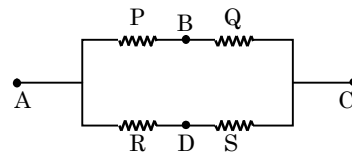

$$\frac{1}{R_{AC}} = \frac{1}{(P+Q)} + \frac{1}{(R+S)}$$

NOTE If the Wheatstone bridge is not balanced or equivalent resistance is to be calculated between the points other than A and C, the above method will not be useful. In such cases the circuit must be solved by applying **Kirchoff's - Laws** or otherwise.

Example Based on

Balanced Wheatstone bridge

Example. 34

Calculate effective resistance between points A and B for the networks shown in fig. A and Fig. B.

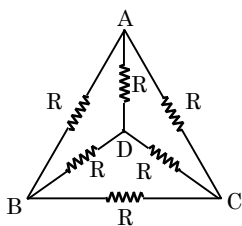

Fig. (A)

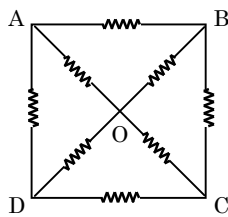

Fig. (B)

Solution.

In the Figure (A) the points B and D are equipotential. Therefore the resistor R_{BD} can be removed. Hence net resistance between points A and C will be

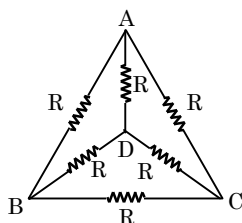

Fig. (A)

$$\frac{1}{R_{AC}} = \frac{1}{2R} + \frac{1}{2R} + \frac{1}{R} = \frac{2}{R} \Rightarrow R_{AC} = \frac{R}{2}$$

Similarly in the figure (B) since hence $V_B = V_D = V_O$ thus we can remove the resistors R_{OB} and R_{OD} therefore the equivalent resistance will be

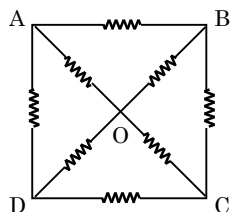
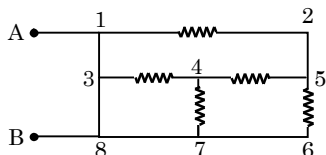

Fig. (B)

$$\frac{1}{R_{AC}} = \frac{1}{2R} + \frac{1}{2R} + \frac{1}{2R} \Rightarrow R_{AC} = \frac{2}{3}R$$

Example. 35

Find the equivalent resistance between the points A and B for the network shown. Each resistor has value R.



Solution.

First Let's rewrite the circuit using point potential method. Note that junction groups [A, 1, 3], [2, 5], [4] and [6, 7, 8, B] can be each treated as separate points. More

over since resistance is to be calculated between points A and B, these should be marked farther as shown.

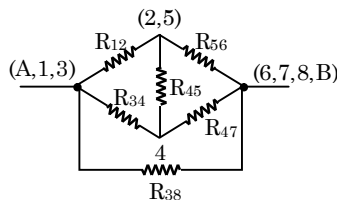

As we can see, the resistor $R_{45} = R$ can be removed as the junctions (2,5) and 4 are at same potential.

$$\text{Hence } \frac{1}{R_{eq}} = \frac{1}{2R} + \frac{1}{2R} + \frac{1}{R}$$

$$\therefore \frac{1}{R_{eq}} = \frac{R}{2}$$

Infinite Circuits

There are two types of infinite circuits which have been popular with the examiners. In the first type a network consists of infinite number of links connected with each other. In the second type you may be given a network in the form of an infinite wire grid. Here we are discussing these two types separately.

(A) Network with infinite number of links :

Such networks are in the form of a long chain of infinite links, with each link containing two or more resistors (see figure).

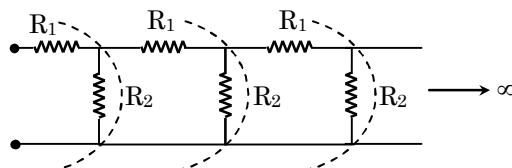

The equivalent resistance of such networks can be easily determined if we apply a simple theory that there will be no appreciable change in the net resistance of the chain even if we remove or add one link from the network. Also keep in your mind that in such cases you will always get answer in the form of a quadratic equation.

(B) Infinite wire grid networks :

Such networks are in the form of an infinite wire grid consisting of triangular, square, pentagonal or even hexagonal cells.

The net resistance of these type of grids can also be determined by using the principles of symmetry of current distribution and their super position.

Example Based on

Infinite circuits

Example. 36

Find the equivalent resistance of the network between the points a and b as shown in the figure.

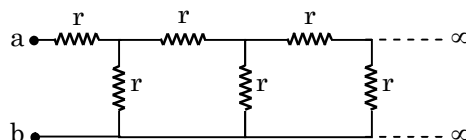

Solution.

Let the equivalent resistance between a and b is R. As the ladder is infinite, R is also the equivalent resistance of the ladder to the right of the points c and d. Thus, we can replace the part to the right of cd by a resistance R and redraw the circuit as shown below.

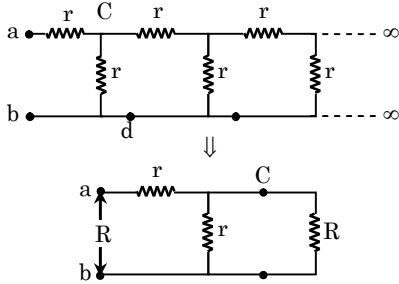

This gives

$R = r + \frac{r \cdot R}{r + R}$, read just this equation in the quadratic form of variable R.

or $R^2 - rR - r^2 = 0$

or $R = \frac{r \pm \sqrt{r^2 + 4r^2}}{2}$

[omit -ve quantity as resistance can not be negative].

$$R = \frac{1 + \sqrt{5}}{2} \cdot r.$$

Example. 37

At what value of resistance R_x in the circuit shown below will the total resistance between points A and B be independent of number of links.

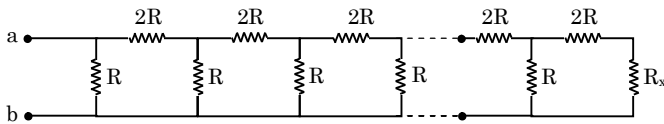

Solution.

In the given network if we add one more link and terminate it by R_x , the net resistance will remain same. Thus, we can reduce the circuit as shown below.

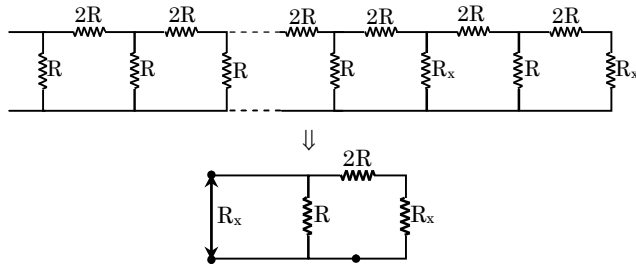

Therefore $R_x = \frac{R(R_x + 2R)}{R + (R_x + 2R)}$

simplifying it in the form of quadratic equation of R_x .

We get $R_x^2 + 2R \cdot R_x - 2R^2 = 0$

$$R_x = \frac{-2R + \sqrt{4R^2 + 8R^2}}{2} = (\sqrt{3} - 1)R$$

Example. 38

There is an infinite grid with hexagonal cells. (See figure). The resistance of each wire between neighbouring joints is equal to R_0 . Find the resistance R of the whole grid between points A and B.

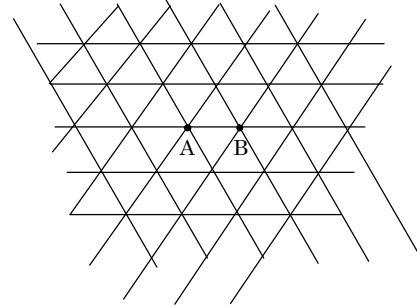

Solution.

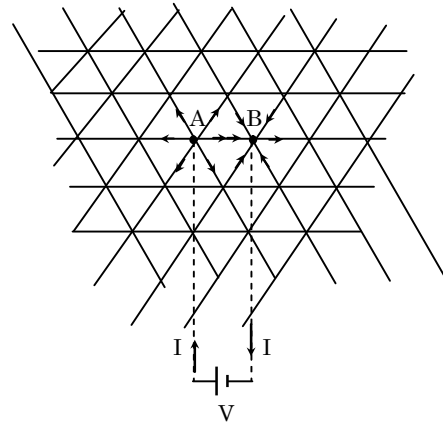

Let's connect the joints A and B with a battery of emf V. If R is the resistance of grid, then the current entering at junction A (from battery) and leaving from junction B will be $I_0 = \frac{V_0}{R}$

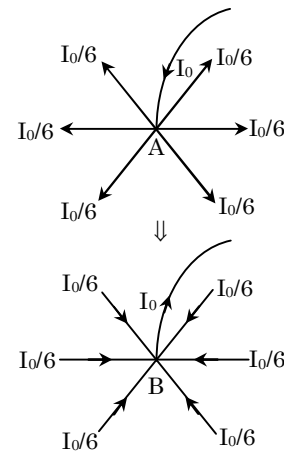

we can say that total current entering the junction A will leave this junction in six equal parts. Therefore current in the wire AB going away from A will be $\frac{I_0}{6}$.

By the principle of symmetry we can also say that the total current leaving the junction B will be I_0 if each of the six wires connected to B supplies current equal to $I_0/6$.

Thus total current in wire AB = current leaving from junction A + Current entering into B = $\frac{I_0}{6} + \frac{I_0}{6}$

$$I = \frac{I_0}{3}$$

Now by ohm's law

$$V = I \cdot R_0 \text{ resistance of wire AB.}$$

$$V = \frac{I_0}{3} \cdot R_0 \Rightarrow V = \left(\frac{R_0}{3}\right) I_0$$

Since I_0 is total current drawn from battery of emf V , hence resistance of grid across AB will be

$$R = \frac{V}{I_0} = \frac{R_0}{3} \Rightarrow R = \frac{R_0}{3}$$

◆ Symmetric Circuits

If distribution of resistors in a network is such that it is identical about any hypothetical line, then the circuit is said to be symmetrical. In other words if a symmetric circuit is broken in two parts about a given line, then one part will be a mirror image of the other.

In such cases the points of the circuit lying on the line of symmetry will be equipotential and therefore can be joined at a single point.

Let us understand the application of this theory with an illustration.

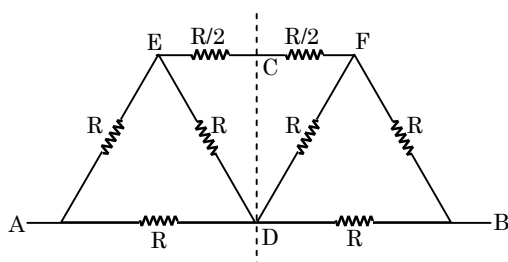

In this circuit the part left to the line of symmetry is identical to the part lying right. Therefore point C and D will be equipotential. Thus we can rewrite the circuit by joining points C and D, as given.

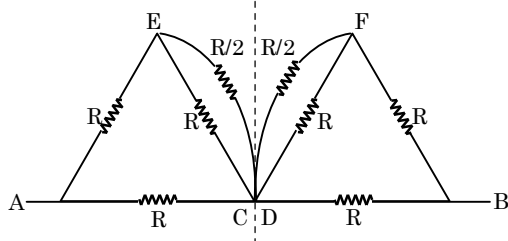

Now we can determine the resistance of any one part. Net resistance will be double the resistance of that part i. e., $R_{AB} = 2 \left[\frac{4}{7} R \right] = \frac{8}{7} R$

$$R_{AB} = 2 \left[\frac{4}{7} R \right] = \frac{8}{7} R$$

Example Based on

Symmetrical circuits

Example. 39

In the network shown each resistor is equal to R . Find the equivalent resistance of the network between the points (i) A and C (ii) E and F. The points E and F are mid points of the side BC and AD respectively.

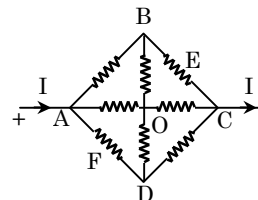

Solution.

(i) Suppose a current I enters the junction A and leaves from C.

For the terminals, A and C, the line BOD will be the line of symmetry. Therefore no current will flow through resistors BO and OD (as the line BOD is equipotential line)

Thus we can see draw the circuit as shown:

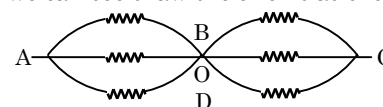

$$\therefore R_{AC} = 2 \left[\frac{R}{3} \right] = \frac{2}{3} R$$

(ii) Similarly if the current I enters at A and leaves from D, the circuit will be symmetric about the line EOF, [BE = FC = $R/2$ and AF = FD = $R/2$]

Proceeding similarly we can get

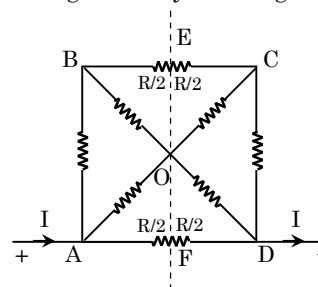

$$R_{AD} = 2 \left[\frac{4}{15} R \right] = \frac{8}{15} R$$

11. COMPLEX CIRCUIT

The circuits which do not fall under the category of the previous categories, may be solved by using Kirchhoff's law.

◆ Kirchhoff's Laws

There are two laws

(a) **Kirchhoff's Junction Law :**

(i) This law is based on the principle of conservation of charges.

- (ii) It states that the algebraic sum of currents coming at a junction is equal to zero. $I = 0$
- (iii) **Sign convention** : Current reaching a junction is taken as positive and current leaving the junction is negative

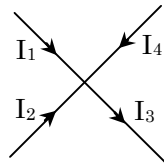

$$\text{Here } I_1 + I_2 - I_3 + I_4 = 0$$

(b) Kirchhoff's Loop Law

- (i) This is based on conservation of energy.
- (ii) It states that in an electric circuit the sum of the potential drop across different components is equal to zero.
- (iii) Sign convention

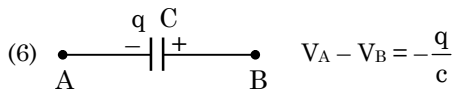
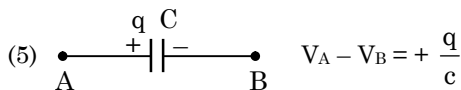
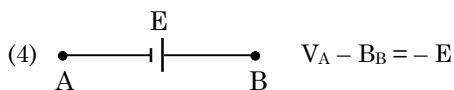
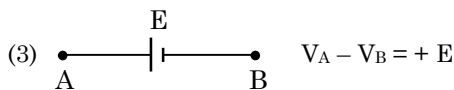
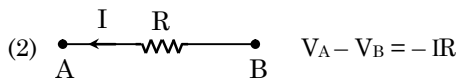
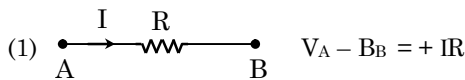

Here we can apply the Kirchhoff's second law in the loop ABCDA and get.

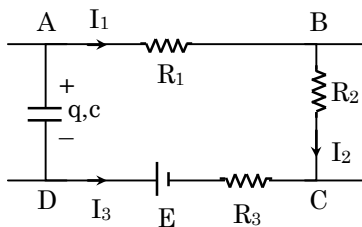

$$+ I_1 R_1 + I_2 R_2 - I_3 R_3 - E - \frac{q}{c} = 0$$

- (c) The following points must be taken into consideration in applying the Kirchhoff's Law.
- (i) Show the direction of current in each branch.
- (ii) In showing the currents in different branches, use Kirchhoff's junction law.
- (iii) Select the loops such a way that each new loop must have at least one new branch not considered previously.

- (iv) The number of loops must be equal to the number of variables.

Example Based on Kirchhoff's Law

Example. 40

Three resistances are joined at a point O and their ends are at potentials V_A , V_B and V_C as shown. Find the potential of the junction O.

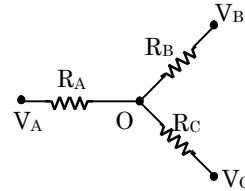

Solution.

Let V_0 be the potential of the point O.

From Kirchhoff's Junction Law

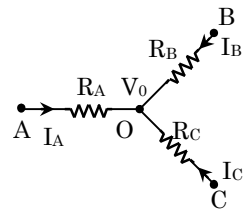

$$I_A + I_B + I_C = 0$$

$$\Rightarrow \frac{V_A - V_0}{R_A} + \frac{V_B - V_0}{R_B} + \frac{V_C - V_0}{R_C} = 0$$

$$\Rightarrow V_0 = \frac{V_A/R_A + V_B/R_B + V_C/R_C}{1/R_A + 1/R_B + 1/R_C}$$

Example. 41

Three 4V batteries of internal resistance 0.1, 0.2 and 0.3 are connected in parallel and in series with a 2.045 ohm resistor. Find

- (a) equivalent resistance for the current
 (b) equivalent voltage
 (c) current in the circuit
 (d) the terminal voltage of equivalent cells
 (e) the terminal voltage of each cell.

Solution.

The circuit arrangement is shown in fig.

As the batteries are connected in parallel, hence total emf of the circuit = 4V.

The effective resistance R_{AB} between A and B is given by

$$\frac{1}{R_{AB}} = \frac{1}{0.1} + \frac{1}{0.2} + \frac{1}{0.3} = \frac{110}{6}$$

$$R_{AB} = \frac{6}{110} = 0.055 \text{ ohm.}$$

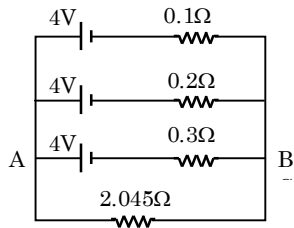

- (a) Equivalent resistance of the circuit
 $R = R_{AB} + 2.045 = 0.055 + 2.045 = 2.1 \text{ ohm}$,
 (b) Equivalent voltage = 4volt
 (c) Current in the circuit = $\frac{4}{2.1} = 1.9 \text{ amp}$.
 (d) Terminal voltage of equivalent cell
 $= 4 - i R_{AB} = 4 - 1.9 \times 0.55$
 $= 4 - 0.1045 = 3.8955 \text{ V}$
 (e) Batteries are in parallel hence terminal voltage for each cell is 3.8955 V.

Example 42

In the circuit shown in fig. E, F, G and H are cells of emf 2, 1, 3 and 1 volts and their internal resistances are 2, 1, 3 and 1 ohm respectively. Calculate

- (i) the potential difference between B and D and
 (ii) the potential difference across the terminals of each of the cells G and H.

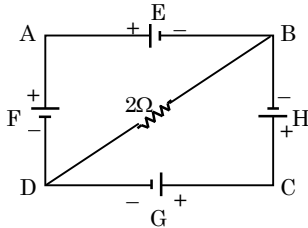

Solution.

Fig. shows the current distribution

Applying Kirchoff's first law at point D,

$$\text{we have } i = i_1 + i_2 \quad \dots (1)$$

Applying Kirchoff's second law to mesh ADBA,

$$\text{we have } 2i + 1i + 2i_1 = 2 - 1 = 1$$

$$\text{or } 3i + 2i_1 = 1 \quad \dots (2)$$

Applying Kirchoff's second law to mesh DCBD,

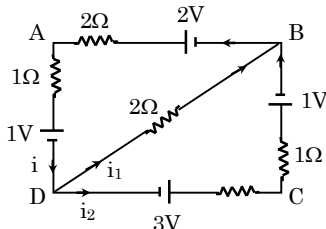

$$\text{we get } 3i_2 + 1i_2 - 2i_1 = 3 - 1$$

$$\text{or } 4i_2 - 2i_1 = 2 \quad \dots (3)$$

Solving eqs. (1), (2) and (3), we get

$$i_1 = \frac{1}{13} \text{ amp.}, i_2 = \frac{6}{13} \text{ amp.}, \text{ and } i = \frac{5}{13} \text{ amp.}$$

- (i) Potential difference between B and D

$$= 2 i_1 = 2 \left(\frac{1}{13} \right) = \frac{2}{13} \text{ volt.}$$

- (ii) Potential difference across G

$$= E - i_2 R = 3 - \frac{6 \times 3}{13} = 1.61 \text{ V.}$$

Potential difference across H

$$= 1 - \left(\frac{-6}{13} \right) (1) = 1.46 \text{ V.}$$

Example 43

AB, BC, CD and DA are resistors of 1, 1, 2 and 2 ohms respectively connected in series. Between A and C is a 1 volt cell of resistance 2 ohms, A being positive. Between B and D is a 2 volt cell of 1 ohm resistance, B being positive. Find the current in each branch of the circuit.

Solution.

The circuit arrangement and the current distribution is shown in fig.

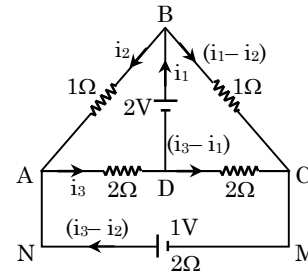

Applying Kirchoff's law to meshes BADB, BCDB and ADCMNA, we have

$$i_2 + 2i_3 + 1 \cdot i_1 = 2$$

$$\text{or } i_1 + i_2 + 2 i_3 = 2 \quad \dots (1)$$

$$1(i_1 - i_2) - 2(i_3 - i_1) + i_1 = 2$$

$$\text{or } 4i_1 - i_2 - 2i_3 = 2 \quad \dots (2)$$

$$\& 2i_3 + 2(i_3 - i_1) + 2(i_3 - i_2) = 1$$

$$\text{or } -2i_1 - 2i_2 + 6i_3 = 1 \quad \dots (3)$$

Solving eqs. (1) and (2) (3), we get

$$i_1 = 0.8 \text{ amp. } i_2 = 0.2 \text{ amp and } i_3 = 0.5 \text{ amp.}$$

∴ Current in AB branch = 0.2 amp.

Current in BC branch = 0.6 amp.

Current in CD branch = 0.3 amp.

Current in AD branch = 0.5 amp.

Current in MN branch = 0.3 amp.

12. JOULE HEATING

- (a) When current pass through a resistor, heat is generated.
 (b) The heat developed per unit time is equal to $I^2 R_0$.
 (c) If current through the resistor is constant, heat generated in time t is $H = I^2 R t$
 (d) If current through the resistor is variable, heat generated in time t is $H = \int I^2 R dt$

Example Based on**Joule heating****Example. 44**

A varying current $I = I_0 \sin \omega t$ is passed through a resistor R . Here I_0 and ω are constants. Find the heat generated in the resistor in time $t = 0$ to $t = 2\pi/\omega$.

Solution.

Heat generated,

$$H = \int_{t=0}^{2\pi/\omega} I^2 R \, dt = \int_{t=0}^{2\pi/\omega} I_0^2 \sin^2 \omega t \cdot R \cdot dt = \frac{\pi I_0^2 R}{\omega}$$

Example. 45

One kilowatt electric heater is to be used with 220 V, DC supply.

- What is the current in the heater ?
- What is its resistance ?
- What is the power dissipated in the heater ?
- How much heat in calories is produced per second ?
- How many grams of water at 100°C will be converted per minute into steam at 100°C with the heater ?

Assume that the heat losses due to radiation are negligible. Latent heat of steam = 540 cal/gm .

Solution.

Here $P = 1 \text{ kW} = 1000 \text{ W}$ and $V = 220 \text{ volt}$.

- Current in the heater

$$i = \frac{P}{V} = \frac{1000 \text{ W}}{220 \text{ V}} = 4.55 \text{ A}$$

- Resistance of heater coil

$$R = \frac{V^2}{P} = \frac{220 \times 220}{1000} = 48.4 \text{ ohm}$$

- Power dissipated in heater = 1000 W

- Heat produced in second

$$H = \frac{V i t}{J} = \frac{\text{Power} \times \text{time}}{J}$$

$$\therefore H = \frac{1000 \times 1}{4.2} = 240 \text{ cal/second}$$

- Heat produced in one minute
= $240 \times 60 = 14400 \text{ cal}$.

We know that 540 cal are required to convert 1 gm of water at 100°C into steam at 100°C .

$$\begin{aligned} \therefore \text{Amount of water at } 100^\circ\text{C converted into steam at } 100^\circ\text{C by } 14400 \text{ cal. of heat} \\ = \frac{14400}{540} = 26.8 \text{ gm} \end{aligned}$$

Example. 46

Three equal resistors connected in series across a source of emf together dissipate 10 watts of power. What would be the power dissipated if the same resistors are connected in parallel across the same source of emf ?

Solution.

Let R be the resistance of each resistor. When they are connected in series, the total resistance = $R + R + R = 3R \text{ ohm}$.

$$\therefore \text{Power dissipated } W_1 = E^2/3R,$$

Where E = emf of the source.

When the resistors are connected in parallel, their effective resistance is given by

$$\frac{1}{R'} = \frac{1}{R} + \frac{1}{R} + \frac{1}{R} = \frac{3}{R} \text{ or } R' = \frac{R}{3}$$

$$\therefore \text{Power dissipated } W_2 = \frac{E^2}{R/3} = \frac{3E^2}{R}$$

$$\text{Now, } \frac{W_2}{W_1} = \frac{3E^2}{R} \times \frac{3R}{E^2} = 9$$

$$\text{or } W_2 = 9 W_1 = 9 \times 10$$

$$= 90 \text{ watt. or } \frac{1}{10} = \frac{1}{P} + \frac{1}{P} + \frac{1}{P}$$

$$\text{or } P = 30$$

$$\text{Now, } P_{\text{parallel}} = P + P + P = 30 + 30 + 30 = 90 \text{ watt}$$

Example. 47

A fuse of lead wire has an area of cross-section 0.2 mm^2 . On short circuiting, the current in the fuse wire reaches 30 A . How long after the short-circuiting, will the fuse be to melt ? for lead, specific heat = $0.032 \text{ cal g}^{-1} (\text{C}^{-1})$, melting point = 327°C , density = 11.34 gm cm^{-3} and the resistivity = $22 \times 10^{-6} \text{ ohm-cm}$. The initial temperature of wire is 20°C . Neglect heat losses.

Solution.

Let ℓ be the length of the fuse wire then its resistance R is given by $R = \rho \ell / A$

$$\begin{aligned} \text{Here } \rho &= 22 \times 10^{-6} \text{ ohm-cm, } A = 0.2 \text{ mm}^2 \\ &= 0.2 \times 10^{-2} \text{ cm}^2 \end{aligned}$$

$$\therefore R = \frac{22 \times 10^{-6} \ell}{0.2 \times 10^{-2}} \quad \dots (1)$$

Let t seconds be the time taken for melting the fuse wire, then

$$\text{Heat produced } H = \frac{i^2 R t}{4.2} \text{ cal.}$$

$$\text{Here } i = 30 \text{ amp. and } R = \frac{22 \times 10^{-6} \ell}{0.2 \times 10^{-2}}$$

$$\therefore H = \frac{(30)^2 \times 22 \times 10^{-6} \times \ell \times t}{4.2 \times 0.2 \times 10^{-2}} \text{ cals} \quad \dots (2)$$

Again $H = msT$

$$\begin{aligned} \text{Here } m &= \text{volume} \times \text{density} = A \times \ell \times \text{density} \\ &= (0.2 \times 10^{-2}) \times \ell \times 11.34 \end{aligned}$$

$$\therefore H = (0.2 \times 10^{-2}) \ell \times 11.34 \times 0.032 \times (327-20) \dots (3)$$

From equations (2) and (3)

$$(0.2 \times 10^{-2}) \ell \times 11.34 \times 0.032 \times 307$$

$$= \frac{(30)^2 \times 22 \times 10^{-6} \times \ell \times t}{4.2 \times 0.2 \times 10^{-2}}$$

solving we get, $t = 0.095$ second.

Example. 48

A copper wire having cross-sectional area 0.5 mm^2 and a length of 0.1 m is initially at 25°C and is thermally insulated from the surrounding. If a current of 10 amp. is set up in this wire,

- find the time in which the wire will start melting. The change of resistance with the temperature of the wire may be neglected.
- what will be the time taken if length of the wire is doubled ?

Given for copper wire, density = $9 \times 10^3 \text{ kgm}^{-3}$
 specific heat = $9 \times 10^2 \text{ Kcal kg}^{-1} (^\circ\text{C})^{-1}$,
 melting point = 1075°C ,
 specific resistance = $1.6 \times 10^{-8} \text{ ohm-meter}$.

Solution.

- The resistance R of copper wire is given by

$$R = \rho \frac{\ell}{A}$$

Here $\rho = 1.6 \times 10^{-8} \text{ ohm-meter}$, $\ell = 0.1 \text{ m}$ and $A = 0.5 \times 10^{-6} \text{ m}^2$

$$\therefore R = \frac{1.6 \times 10^{-8} \times 0.1}{0.5 \times 10^{-6}} = 0.00032 \text{ ohm.}$$

If H is the heat required to melt the copper wire then

$$H = \frac{i^2 R t}{4.2} = \text{mass of copper wire} \times S \times T$$

Here $i =$ current through the wire = 10 amp ,
 $R = 0.00032 \Omega$

mass of the copper wire = volume \times density
 $= 0.5 \times 0.1 \times 10^{-6} \times 9 \times 10^3 \text{ kg} = 45 \times 10^{-5} \text{ kg}$
 $s = 0.09$ and $T = (1075 - 25) = 1050$

$$\therefore \frac{(10)^2 \times 0.00032 \times t}{4.2} = (45 \times 10^{-5}) (0.09) (1050)$$

Solving we get $t = 558$ seconds.

- When the length of the wire is doubled, its resistance is doubled. At the same time, the mass of the wire is also doubled. Using the expression

$$\frac{i^2 (2R)t}{4.2} = (2m) s T.$$

we can say that time t remains the same

$$\therefore t = 558 \text{ seconds.}$$

Example. 49

In the circuit shown in the fig. the 5 ohm resistance develops 10.23 cal s^{-1} due to the current flowing through it. Calculate

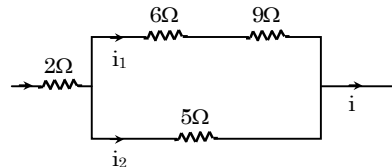

- the heat developed per second in the 2 ohm resistance and
- the potential difference across 6 ohm resistance.

Solution.

- Let a current i flows through 2 ohm resistance. The current is divided into two parts. Let current i_1 flows through 6 ohm and 9 ohm and i_2 flows through 5 ohm . The effective resistance of 6 ohm and 9 ohm is 15 ohm . Now

$$i_1 = i \cdot \frac{5}{20} = \frac{i}{4} \text{ amp.}$$

$$\text{and } i_2 = i \cdot \frac{15}{20} = \frac{3i}{4} \text{ amp.}$$

\therefore Heat developed in 5 ohm resistor in one second

$$H = \frac{i^2 R t}{4.2} \text{ cal.} = \frac{(3i/4)^2 \times 5 \times 1}{4.2}$$

But according to the problem,

$$H = 10.24 \text{ cal s}^{-1}$$

$$\therefore \frac{(3i/4)^2 \times 5 \times 1}{4.2} = 10.24$$

Solving we get $i = 3.92 \text{ A}$.

\therefore Heat developed in 2 ohm resistor in one second

$$= \frac{i^2 R t}{4.2} \text{ cal.} = \frac{(3.92)^2 (2)(1)}{4.2} = 7.28 \text{ cal.}$$

- Potential difference across 6 ohm resistor
 $=$ current \times resistance

$$= i_1 \times 6 = \frac{i \times 6}{4} = \frac{3.92}{4} \times 6 = 5.86 \text{ volt}$$

Example. 50

A galvanometer having a coil resistance of 100 ohms gives a full scale deflection when a current of one milli ampere is passed through it. What is the value of resistance which can convert this galvanometer into ammeter giving a full scale deflection for a current of 10 amperes ?

A resistance of the required value of is available but it will get burnt if the energy dissipated in it is greater than one watt. Can it be used for the above described conversion of the galvanometer?

When this modified galvanometer is connected across the terminals of battery, it shows a current 4 amp. The current drops to 1 amp., when the resistance of 1.5 ohm is connected in series with modified galvanometer. Find the emf and internal resistance of battery.

Solution.

(i) In this case a shunt S should be connected in parallel with galvanometer. Now

$$\frac{S}{S+G} = \frac{10^{-3}}{10} \quad \text{or} \quad \frac{S}{S+100} = \frac{1}{1000}$$

$$S = \frac{1}{99.99} \text{ ohm}$$

(ii) Power dissipated in the shunt

$$= i^2 S = (9.999)^2 \times \frac{1}{99.99}$$

$$(\therefore \text{Current in the shunt} = 10 - 0.001 = 9.999 \text{ amp.})$$

$$\therefore P = 0.9999 \text{ Watt}$$

This is less than one watt. Hence the above shunt can be safely used.

(iii) Let E be the e.m.f. and r be the internal resistance of the cell. If R be the combined resistance of shunted galvanometer, then

$$\frac{1}{R} = \frac{1}{100} + \frac{9999}{100}$$

$$\therefore R = 0.01 \text{ ohm.}$$

$$\text{The current } i = \frac{E}{R+r}$$

$$\therefore 4 = \frac{E}{0.01+r} \quad \dots(i)$$

$$\text{and } 1 = \frac{E}{0.01+r+1.5} \quad \dots(ii)$$

Solving eqs. (i) and (ii), we get

$$E = 2 \text{ volt and } r = 0.49 \text{ ohm}$$

Example. 51

Two bulbs rated at 25 watts, 110 volts of 100 watts, 110 volts are connected in series to 220 volts electric supply. Perform the necessary calculations to find out which of the two bulbs, if any, will fuse. What would happen if the two bulbs were connected in parallel to the same supply.

Solution.

Let i_1 and i_2 be the currents which can flow through the two lamps safely, then

$$i_1 = \frac{25}{110} = 0.227 \text{ amp.}$$

$$\text{and } i_2 = \frac{100}{110} = 0.909 \text{ amp.}$$

The resistance of two bulbs are given by

$$R_1 = \frac{E}{i_1} = \frac{110}{0.227} \text{ ohm}$$

$$\text{and } R_2 = \frac{110}{0.909} \text{ ohm}$$

When the two bulbs are connected in series, their total resistance

$$R = R_1 + R_2 = \frac{110}{0.227} + \frac{110}{0.909} = 605 \text{ ohm}$$

When these two lamps are connected in series to 220 volts, the current passing through then is given by

$$i = \frac{220}{605} = 0.363 \text{ amp.}$$

Thus the first bulb will fuse because the current passing through it i.e., 0.363 is more than $i_1(0.227)$

When the two bulbs are connected in parallel, the effective resistance R' is given by

$$\frac{1}{R'} = \frac{1}{R_1} + \frac{1}{R_2} = \frac{0.227}{110} + \frac{0.909}{110} = \frac{1.136}{110}$$

$$R' = \frac{110}{1.136} \text{ ohm}$$

Current flowing through circuit

$$i' = \frac{220}{R'} = \frac{220 \times 1.136}{110} \text{ amp.}$$

Let i_3 and i_4 be the currents passing through the two bulbs as shown in fig.

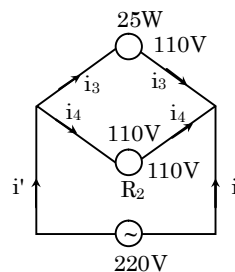

Now the potential difference across the two bulbs is the same.

$$\text{Hence, } i_3 R_1 = i_4 R_2$$

$$i_3 \frac{110}{0.227} = i_4 \frac{110}{0.909}$$

$$\text{or } 4i_3 = i_4 \quad \dots(1)$$

$$\text{again } i_3 + i_4 = i' = \frac{220 \times 1.136}{110} \quad \dots(2)$$

Solving eqs. (1) and (2), get

$$i_3 = 0.454 \text{ amp. and } i_4 = 1.816 \text{ amp.}$$

Thus both the bulbs will fuse.

Example. 52

An ammeter and a voltmeter are connected in series to a battery with an e.m.f. $E = 6.0$ V. When a certain resistance is connected in parallel with the voltmeter, the reading of the latter decrease $\eta = 2.0$ times, whereas the readings of the ammeter increase the same number of times. Find the voltmeter readings after the connection of the resistance.

Solution.

Let the initial readings of ammeter be I and that of voltmeter, V . When R' is connected in parallel with the voltmeter, let I' be the reading of ammeter and V_1' , that of voltmeter.

Now given that $I' = \eta I$ and $V' = \frac{V}{\eta}$. If in figure, I_1 is

the current entering voltmeter,

then $V' = (I' - I_1)R$.

Now for the main circuit,

$$E = I' R_A + (I' - I_1) R = 0$$

$$\Rightarrow E = I' R_A + V'$$

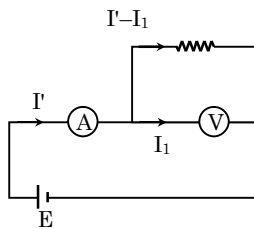

$$\Rightarrow R_A = \frac{E - V'}{I'} \quad \dots(i)$$

When no resistance is connected,

$$E = I R_A + V$$

$$\Rightarrow R_A = \frac{E - V}{I} \quad \dots(ii)$$

From equs (i) and (ii) .

$$\frac{I}{I'} = \frac{E - V}{E - V'} \Rightarrow \frac{1}{\eta} = \frac{E - \eta V'}{E - V'}$$

$$\Rightarrow E - V' = \eta E - \eta^2 V' \Rightarrow V' = (\eta^2 - 1) = \eta (E - 1)$$

$$\Rightarrow V = \frac{\eta - 1}{\eta^2 - 1} E .$$

With the given values,

$$V' = \frac{(2-1)6.0}{2^2-1} = \frac{6}{3} = 2V$$

13. ELECTRICAL INSTRUMENTS

◆ Bulbs

- Bulbs are rated to consume power at a given voltage. For example 100W, 220 Volt.
- Power consumption is a variable quantity whereas its resistance is definite.
- Resistance, $R = \frac{V^2}{P}$.

- When bulbs with rating P_1, P_2, P_3 at same voltage V are connected in parallel and to a voltage V , they will consume power as specified.

$$P = P_1 + P_2 + P_3 + \dots$$

- When bulbs with rating P_1, P_2, P_3 at same voltage V are connected in series, power consumed by all the bulbs are less than specified. Net power consumption P is given by

$$\frac{1}{P} = \frac{1}{P_1} + \frac{1}{P_2} + \frac{1}{P_3} + \dots$$

- When the circuit is complex, replace the bulb by pure resistance and solve the circuit.

◆ Galvanometer

- Galvanometer is an instrument which is sensitive to current. Whenever current flows through it, it gives deflection, and hence one can measure the current.
- Voltmeter is an instrument which measures potential difference between two points.
- Ammeter is an instrument which measures the current flowing through a particular branch.
- Voltmeter and ammeter are basically made from Galvanometers only.

(A) Conversion of Galvanometer to Volt Meter or to Enhance the Range of Voltmeter :

Let, V_g = Potential difference applied across the voltmeter to give full scale deflection.

G = Galvanometer resistance.

V = The range of the voltmeter to be enhanced to

R = Resistance connected in series to the voltmeter to achieve the requirement.

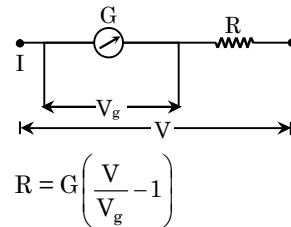

DERIVATION

Since the galvanometer and the resistance R are connected in series, they will draw same current.

$$\therefore I = \frac{V_g}{G} = \frac{V}{G + R} \Rightarrow R = G \left(\frac{V}{V_g} - 1 \right)$$

(B) Conversion of the Galvanometer to Ammeter or to Enhance the Range of the Ammeter:

Let, I_g = current required through the galvanometer to give full scale deflection.

G = Resistance of the galvanometer.

V = The range of the ammeter to be enhanced to

r = resistance connected in parallel to the galvanometer

$$r = \frac{G}{I/I_g - 1}$$

DERIVATION

Since galvanometer and the resistor are connected in parallel, potential difference across them will be same.

$$\therefore I_g \cdot G = (I - I_g) \cdot r$$

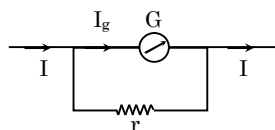

$$\Rightarrow r = \frac{G}{I/I_g - 1}$$

NOTE (i) The resistance of ideal voltmeter is infinite.
(ii) The resistance of ideal ammeter is zero.

◆ Potentiometer

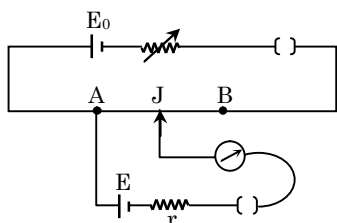

- (a) Potentiometer is a device to measure the potential difference between two points.
- (b) The instrument is a better device compared to voltmeter.
- (c) A typical circuit of potentiometer is shown in the fig.
- (d) The wire AB is called potentiometer wire. It is made of uniform cross-section so that resistance per unit length of the wire is uniform.
- (e) The point J is moved such that there is no deflection in the galvanometer, hence potential difference across AJ is equal to E.
 $\therefore E \propto \ell$
- (f) To get a null point or no deflection in the galvanometer, emf E_0 must be greater than E.

(A) Use of Potentiometer to Compare the Emf's of Two Cells :

When switch is in position (1), null point is obtained in the galvanometer at length ℓ_1 from the point A, $E_1 \propto \ell_1$

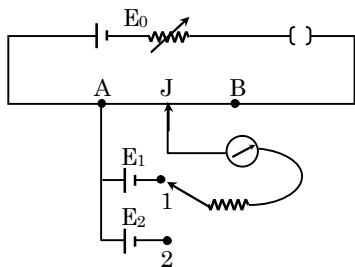

And when switch is in position (2), null point is obtained in the galvanometer at length ℓ_2 .

$$\therefore E_2 \propto \ell_2$$

$$\text{Thus } \frac{E_1}{E_2} = \frac{\ell_1}{\ell_2}$$

(B) Use of Potentiometer to Calculate the Internal Resistance of a Cell :

When switch K_1 is closed and K_2 is opened ; the null point is obtained at a length ℓ_1 .

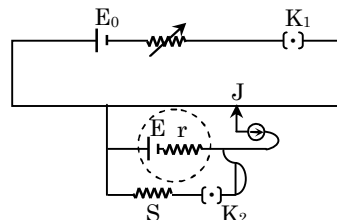

$$\therefore E_0 \propto \ell_1 \quad \dots(i)$$

When switch K_2 is also closed, the null point is obtained at a length ℓ_2 .

$$\therefore V \propto \ell_2 \quad \dots(ii)$$

where V is the potential difference across the cell when switch K_2 is closed.

$$V = \frac{E}{r + R} \cdot R \quad \dots(iii)$$

$$\therefore \frac{E}{V} = \frac{\ell_1}{\ell_2}$$

$$\Rightarrow \frac{E}{\frac{E \cdot R}{r + R}} = \frac{\ell_1}{\ell_2} \Rightarrow r = R \cdot \frac{\ell_1 - \ell_2}{\ell_1}$$

14.R-C CIRCUIT

When resistance and capacitor are connected in series with or without cell in an electric circuit, the circuit is called R- C circuit.

◆ Charging of a Capacitor

A resistor of resistance R and an uncharged capacitor of capacitance C are connected in series with a cell of emf E. The switch k is closed at $t = 0$.

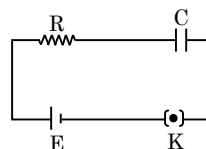

- (a) The current in the circuit at any instant t is given by

$$I(t) = \frac{E}{R} e^{-t/RC}$$

- (b) The charge on the capacitor at any time t,

$$q(t) = CE (1 - e^{-t/RC})$$

(c) At $t = 0$, $I = \frac{E}{R}$

which is maximum and charge $q = 0$

(d) Steady state is reached at $t = \infty$.

Steady state current,

$I(t = \infty) = 0$ and steady state charge

$q(t = \infty) = CE$

(e) Plot of I versus t Plot of q versus t

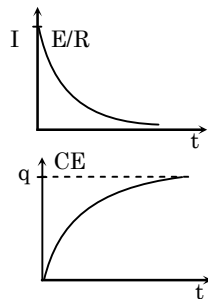

(f) $\tau = RC$ is called the time constant.

DERIVATION

Let I be the current in the circuit and q be the charge on the capacitor at any instant t .

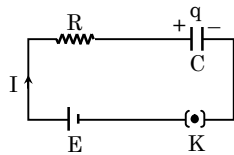

Applying Kirchhoff's law in the loop.

$$E = IR + \frac{q}{c} \quad \dots (i)$$

$$I = \frac{dq}{dt} \quad \dots (ii)$$

On substituting for I in equation (i),

$$\frac{q}{c} + R \frac{dq}{dt} = E$$

On solving and putting the initial condition at $t = 0$, $q = 0$, we get

$$q = CE(1 - e^{-t/RC}) = CE(1 - e^{-t/\tau})$$

on differentiating

$$I = \frac{dq}{dt} = \frac{E}{R} e^{-t/RC} = \frac{E}{R} e^{-t/\tau}$$

◆ **Discharging of a Capacitor**

A charged capacitor is connected in series with a resistance R . Let q_0 be the charge on the capacitor at $t = 0$

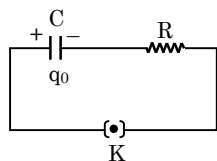

(a) The current in the circuit at any instant t is given by

$$I = \frac{q_0}{RC} e^{-t/RC}$$

(b) The charge on the capacitor at any instant t is

$$q = q_0 e^{-t/RC}$$

(c) at $t = 0$, $I(t = 0) = \frac{q_0}{RC}$

which is maximum and charge $q(t = 0) = q_0$

(d) at steady state $t = \infty$, $I(t = \infty) = 0$

and charge, $q(t = \infty) = 0$

(e) Plot of I versus t Plot of q versus t

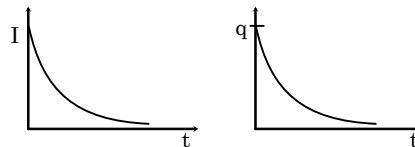

(f) $\tau = RC$ is called time constant. (Its dimension is equal to time)

DERIVATION

Let I be the current in the circuit and q be the charge on the capacitor at any instant. Applying Kirchhoff's law

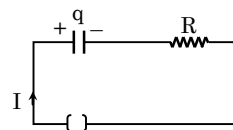

$$\frac{q}{c} + IR = 0, I = \frac{dq}{dt}$$

$$\therefore R \frac{dq}{dt} + \frac{q}{c} = 0$$

on solving and putting initial condition

$t = 0$, $q = q_0$,

We get, $q = q_0 e^{-t/RC}$ and on differentiating,

$$I = \frac{dq}{dt} = - \frac{q_0}{RC} e^{-t/RC}$$

The minus sign signifies that the assumed current direction is opposite to the actual direction.

◆ **Important Points Regarding R-C Circuit**

(a) If capacitor is uncharged it behaves as zero resistance wire.

(b) If capacitor is fully charged, it behaves as infinite resistance wire. No current will flow in the branch having a fully charged capacitor.

(c) If charge on a capacitor is known at any instant, the current can be obtained by simplifying the circuit by replacing the capacitor by a cell of emf q/c with proper polarity.

- (d) If a charged capacitor is discharged through a resistor, the heat produced in the resistor is equal to the energy stored on the capacitor.

$$H = \frac{1}{2} CV^2$$

The heat produced in the resistor does not depend on the value of resistance. Even if a zero resistance wire is connected, the heat produced will be same.

- (e) In case of charging, the charge stored on a capacitor in one time-constant is 37% of the maximum charge.
- (f) Similarly, in case of discharging, the current in the circuit is 37% of the maximum in one time constant.

Example Based on

R - C Circuit

Example. 53

In the circuit shown in fig. the sources have e.m.f. $E_1 = 1.0 \text{ V}$ and $E_2 = 2.5 \text{ V}$ and the resistance have the values $R_1 = 10\Omega$ and $R_2 = 20\Omega$. The internal resistances of the sources are negligible. Find the potential difference $V_A - V_B$ between the plates A and B of the capacitor C.

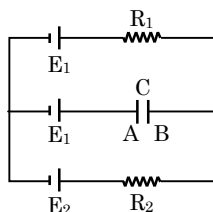

Solution.

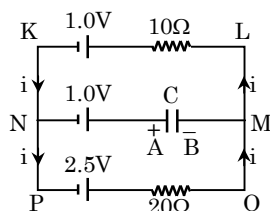

The current flowing in the circuit is shown in fig. The current will not flow through the capacitor.

Applying Kirchoff's law to mesh POLKP, we have $20i + 10i = 2.5 - 1.0$ or $30i = 1.5$

$$\therefore i = \frac{1.5}{30} = 0.05 \text{ amp.}$$

Applying Kirchoff's law to mesh POMNP, we have

$$20i + \frac{q}{C} = 2.5 - 1$$

$$\text{or } \frac{q}{C} = 1.5 - 20i = 1.5 - 20 \times 0.05$$

$$\text{or } \frac{q}{C} = 0.5 \text{ volts}$$

Example. 54

The capacitors shown in fig. has been charged to a potential difference of V volts so that it carries a charge CV with both the switches S_1 and S_2 remaining open. Switch S_1 is closed at $t = 0$. At $t = R_1 C$ switch S_1 is opened and S_2 is closed. Find the charge on the capacitor at $t = 2R_1 C + R_2 C$

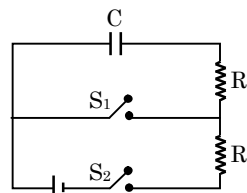

Solution.

When the switch S_1 is closed and S_2 is open. The circuit now becomes as shown in fig.

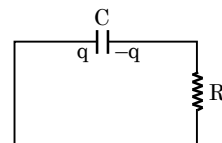

$$\text{Now } q = CVe^{-t/R_1 C}$$

At $t = R_1 C$, the charge on the capacitor will be $q = CV e^{-1} = CV/e$

At this position, S_2 is closed and S_1 is opened. The circuit now becomes as shown in fig.

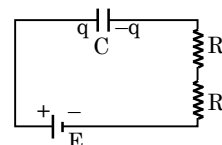

$$R = R_1 + R_2$$

$$\therefore \frac{dq}{dt} = \frac{CE - q}{RC} \text{ or } \frac{dq}{CE - q} = \frac{dt}{RC}$$

Integrating within proper limits, we have

$$\int_{CV/e}^{q_f} \frac{dq}{CE - q} = \int_{R_1 C}^{2R_1 C + R_2 C} \frac{dt}{R_1 C}$$

Solving we get

$$CE - q_f = \frac{CE}{e} - \frac{CV}{e^2}$$

$$q_f = CE - \frac{CE}{e} + \frac{CV}{e^2}$$

$$\text{or } q_f = CE \left(1 - \frac{1}{e} \right) + \frac{CV}{e^2}$$

Example. 55

In the circuit shown in fig. e.m.f. and internal resistance of battery are 6V & 0.5 Ω respectively. Calculate charge on each capacitor in steady state.

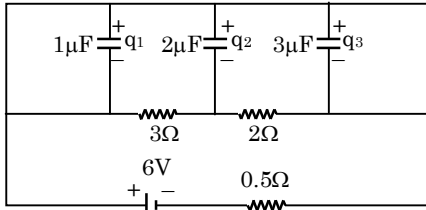

Solution.

In steady state, no current flows through the capacitors. The circuit in this state will be like shown in fig.

Applying Kirchoff's voltage law to mesh 1 and mesh 2 respectively, we have

$$3i_2 + 2i_2 + 0.5 i_1 = 6 \quad \dots(i)$$

$$2(i_1 - i_2) + 3(i_1 - i_2) - 2i_2 - 3i_2 = 0 \quad \dots(ii)$$

Solving these equations, we get

$$i_1 = 2\text{amp. and } i_2 = 1 \text{ amp.}$$

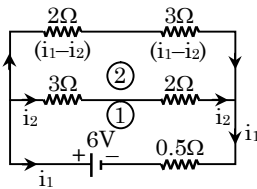

Let, in the steady state, the charges on capacitors of capacitances 1μF and 3μF be q_1 , q_2 and q_3 respectively as shown in fig.

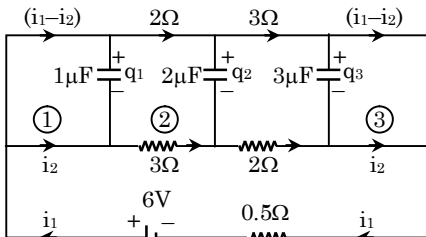

Applying KVL to mesh 1, we have

$$\frac{q_1}{1 \times 10^{-6}} = 0 \text{ or } q_1 = 0$$

Applying KVL to mesh 2, we get

$$2(i_1 - i_2) + \frac{q_2}{2 \times 10^{-6}} - 3 i_2 - \frac{q_1}{1 \times 10^{-6}} = 0$$

$$q_2 = 2 \times 10^{-6} \text{ C or } q_2 = 2 \mu\text{C}$$

Similarly, applying KVL to-mesh 3, we get

$$\frac{-q_3}{3 \times 10^{-6}} = 0 \text{ or } q_3 = 0$$

Example. 56

In the circuit below, the capacitance of each capacitor is equal to C and the resistance R. One of the capacitors was connected to a voltage V_0 and then at the moment $t = 0$ was shorted by means of a switch Sw find :

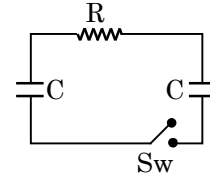

- a current I in the circuit as a function of time ;
- the amount of heat generated provided a dependence I(t) is known.

Solution.

- At the instant, when the switch is closed, then the charge on one of the capacitors, $q_0 = CV_0$ will flow on closing the switch and the current flowing $I = \frac{dq}{dt}$.

From Kirchoff's Laws:

$$\frac{q}{C} + \frac{q}{C} + IR = V_0 \Rightarrow \frac{2q}{C} + R \frac{dq}{dt} = V_0$$

$$\Rightarrow \frac{dq}{CV_0 - 2q} = \frac{dt}{RC}$$

$$\text{Integrating, } \log_e \frac{q - \frac{CV_0}{2}}{-\frac{CV_0}{2}} = -\frac{2t}{RC}$$

$$\text{or, } q = \frac{CV_0}{2} (1 - e^{-2t/RC})$$

$$\text{and } I = \frac{dq}{dt} = \frac{V_0}{R} e^{-2t/RC}$$

- Heat generated $Q =$ Initial energy of the capacitors :

$$Q = \frac{1}{2} \left(\frac{C}{2} \right) V_0^2 = \frac{CV_0^2}{4}$$

or from a knowledge of I(t)

$$Q = \int_0^\infty I^2(t) R dt = \frac{V_0^2}{R} \cdot R \int_0^\infty e^{-4t/RC} dt$$

$$= \frac{1}{4} CV_0^2$$

SOLVED EXAMPLES

Ex.1 A network of nine conductors connects six points A, B, C, D, E and F as shown. The figures denote resistances in ohms. The equivalent resistance between A and D is

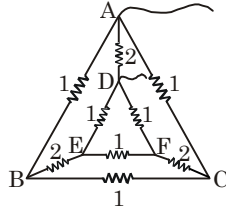

Sol. B and c are equipotential points and so are E and F. Here the circuit can be redrawn as shown in Figure. 1Ω and 1Ω in parallel sum up to $1/2W$; $2W$ and $2W$ in parallel sum up to $1W$; $1/2W$, $1W$, $1/2W$ in series sum up to $1/2 + 1 + 1/2 = 2\Omega$; 2Ω and 2Ω in parallel sum up to $= 1\Omega$.

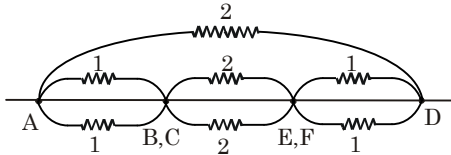

Ex.2 In the network shown in the figure below, calculate the potential difference between A and B.

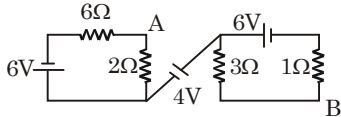

Sol. The distribution of current is shown in Fig., keeping in view that the inflow and outflow of current in a cell must be the same. Applying the loop rule to the left and right loops.

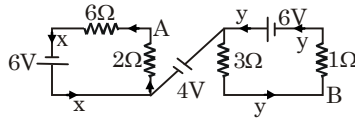

$$2x + 6x = 6$$

$$\text{or } x = 0.5 \text{ A}$$

$$\text{and } 3y + 1y = 6$$

$$\text{or } y = 1.5 \text{ A}$$

$$V_{AB} = \sum ir - \sum e = (-2 \times 0.5 + 3 \times 1.5) - 4 = -0.5 \text{ V}$$

The minus sign shows that B is at a higher potential than A. Thus

$$V_{BA} = -1 \text{ V}$$

Ex.3 Find the resistance of a wire frame shaped as a cube when measured between points 1 and 7. The resistance of each edge is r .

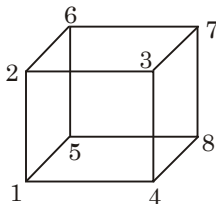

Sol. Symmetry about entrance point 1 and exit point 7 shows that 2, 4, 5 are equipotential points and 5, 6, and 8 are equipotential points. Hence the circuit can be redrawn as shown in Figure. The resistance r , r and r in parallel sum up to $r/3$.

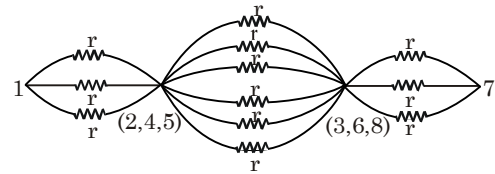

r, r, r, r, r, r in parallel sum up to $r/6$ and r, r, r in parallel sum up to $r/3$. Next $r/3, r/6, r/3$ in series sum up to $5r/6$.

Ex.4 Two resistors with temperature coefficients of resistance α_1 and α_2 have resistances R_{01} and R_{02} at 0°C . Find the temperature coefficient of the compound resistor consisting of the two resistors connected in parallel.

Sol. $R_1 = R_{01} (1 + \alpha_1 t)$

and $R_2 = R_{02} (1 + \alpha_2 t)$

Also $R = \frac{R_1 R_2}{R_1 + R_2} = R_0 (1 + \alpha t)$

and $R_0 = \frac{R_{01} R_{02}}{R_{01} + R_{02}}$

$$\therefore \frac{R_{01} R_{02}}{R_{01} + R_{02}} (1 + \alpha t)$$

$$= \frac{R_{01} R_{02} (1 + \alpha_1 t)(1 + \alpha_2 t)}{R_{01} + R_{02} + (R_{01} \alpha_1 + R_{02} \alpha_2) t}$$

$$\Rightarrow (1 + \alpha t) = \frac{(1 + (\alpha_1 + \alpha_2) t)}{1 + \frac{R_{01} \alpha_1 + R_{02} \alpha_2}{R_{01} + R_{02}} t}$$

$$= (1 + (\alpha_1 + \alpha_2) t) \left(1 - \frac{R_{01} \alpha_1 + R_{02} \alpha_2}{R_{01} + R_{02}} t \right)$$

$$\Rightarrow 1 = \alpha t$$

$$= 1 + 1 + (\alpha_1 + \alpha_2) t - \frac{R_{01} \alpha_1 + R_{02} \alpha_2}{R_{01} + R_{02}} t$$

$$= 1 + \frac{R_{01} \alpha_1 + R_{02} \alpha_1 + R_{01} \alpha_2 + R_{02} \alpha_2 - R_{01} \alpha_1 - R_{02} \alpha_2}{R_{01} + R_{02}} t$$

$$= 1 + \frac{R_{02} \alpha_1 + R_{01} \alpha_2}{R_{01} + R_{02}} t$$

$$\alpha = \frac{R_{02} \alpha_1 + R_{01} \alpha_2}{R_{01} + R_{02}}$$

Ex.5 Find the currents going through the three resistors R_1 , R_2 and R_3 in the circuit of figure.

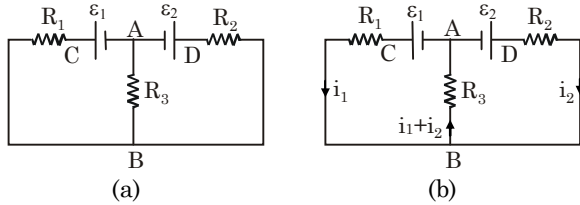

Sol. Let us take the potential of the point A to be zero. The potential at C will be ϵ_1 and that at D will be ϵ_2 . Let the potential at B be V . The currents through the three resistors are i_1 , i_2 and $i_1 + i_2$ as shown in figure. Note that the current directed towards B equals the current directed away from B.

Applying Ohm's law to the three resistors R_1 , R_2 and R_3 we get

$$\epsilon_1 - V = R_1 i_1 \quad \dots(i)$$

$$\epsilon_2 - V = R_2 i_2 \quad \dots(ii)$$

and $V - 0 = R_3 (i_1 + i_2) \quad \dots(iii)$

Adding (i) and (iii),

$$\begin{aligned} \epsilon_1 &= R_1 i_1 + R_3 (i_1 + i_2) \\ &= (R_1 + R_3) i_1 + R_3 i_2 \quad \dots(iv) \end{aligned}$$

and adding (ii) and (iii),

$$\begin{aligned} \epsilon_2 &= R_2 i_2 + R_3 (i_1 + i_2) \\ &= (R_2 + R_3) i_2 + R_3 i_1 \quad \dots(v) \end{aligned}$$

Equations (iv) and (v) may be directly written from Kirchhoff's loop law applied to the left half and the right half of the circuit.

Multiply (iv) by $(R_2 + R_3)$, (v) by R_3 and subtract to eliminate i_2 . This gives

$$i_1 = \frac{\epsilon_1 (R_2 + R_3) - \epsilon_2 R_3}{(R_1 + R_3)(R_2 + R_3) - R_3^2}$$

$$i_1 = \frac{\epsilon_1 (R_2 + R_3) - \epsilon_2 R_3}{R_1 R_2 + R_2 R_3 + R_3 R_1}$$

Similarly eliminating i_1 from (iv) and (v) we obtain,

$$i_2 = \frac{\epsilon_2 (R_1 + R_3) - \epsilon_1 R_3}{R_1 R_2 + R_2 R_3 + R_3 R_1}$$

And so,

$$i_1 + i_2 = \frac{\epsilon_1 R_2 + \epsilon_2 R_1}{R_1 R_2 + R_2 R_3 + R_3 R_1}$$

Ex.6 A capacitor is connected to a 12 V battery through a resistance of 10Ω . It is found that the potential difference across the capacitor rises to 4.0 V in $1 \mu\text{s}$. Find the capacitance of the capacitor (given $\ln(3/4) = 0.405$).

Sol. The charge on the capacitor during charging is given by

$$Q = Q_0 (1 - e^{-t/RC})$$

Hence, the potential difference across the capacitor is

$$V = Q/C = Q_0 / C (1 - e^{-t/RC})$$

Here at $t = 1 \mu\text{s}$, the potential difference is 4 V whereas the steady state potential difference is

$$Q_0 / C = 12 \text{ V So,}$$

$$4V = 12 \text{ V } (1 - e^{-t/RC})$$

or, $1 - e^{-t/RC} = \frac{1}{3}$

or, $e^{-t/RC} = \frac{2}{3}$

or, $\frac{t}{RC} = \ln\left(\frac{3}{2}\right) = 0.405$

or, $RC = \frac{t}{0.405} = \frac{1 \mu\text{s}}{0.405} = 2.469 \mu\text{s}$

or, $C = \frac{2.469 \mu\text{s}}{10 \Omega} = 0.25 \mu\text{F}$

Ex.7 All the edges of a block with parallel faces are unequal. Its longest edge is twice its shortest edge. The ratio of the maximum to minimum resistance between parallel faces is

Sol. Let the edges be 2ℓ , a and ℓ , in decreasing order.

$$R_{\max} = \rho \frac{2\ell}{a\ell}$$

$$R_{\min} = \rho \frac{\ell}{2\ell a} = \frac{\rho}{2a}$$

$$\frac{R_{\max}}{R_{\min}} = 4$$

Ex.8 A, B and C are voltmeters of resistances R , $1.5 R$ and $3 R$ respectively. When some potential difference say V is applied between X and Y, the voltmeter readings are V_A , V_B and V_C respectively. What are the values of V_A , V_B & V_C ?

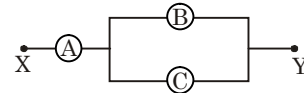

Sol.

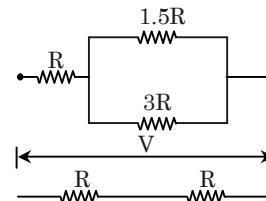

$$V_A = V_B = V_C = \frac{V}{2}$$

Ex.9 A parallel-plate capacitor of capacitance C , filled with a dielectric of dielectric constant k , and charged to a potential V_0 . It is now disconnected from the cell and the slab is removed. If it now discharges, with time constant τ , through a resistance, the potential difference across it will be V_0 after what time.

Sol.

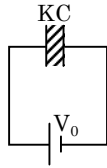

$$Q = KCV_0$$

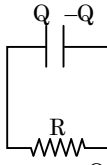

$$q = Qe^{-t/\tau}$$

$$\Rightarrow \frac{q}{C} = \frac{Q}{C} e^{-t/\tau}$$

$$V_0 = \frac{KCV_0}{C} e^{-t/\tau}$$

$$\Rightarrow V_0 = KV_0 e^{-t/\tau}$$

$$\frac{1}{K} = e^{-t/\tau}$$

$$\text{or } \log K = \frac{t}{\tau}$$

$$t = \tau \log_e K$$

Ex.10 A charged capacitor C_1 is discharged through a resistance R by putting switch S in position 1 of circuit shown in Fig. when discharge current reduces to I_0 , the switch is suddenly shifted to position 2.

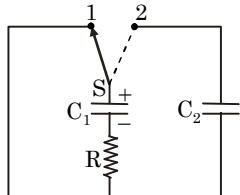

Calculate the amount of heat liberated in resistor R starting from this instant. Calculate also, current I through the circuit as a function of time.

Sol.

Let charge on capacitor C_1 be q_0 when switch was shifted from position 1 to position 2. Just before shifting of switch, circuit was as shown in fig. Applying Kirchoff's voltage law on the circuit Fig.

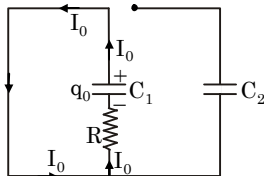

$$\frac{q_0}{C_1} - I_0 R = 0 \quad \text{or} \quad q_0 = I_0 RC_1$$

When switch is shifted from position 1 to position 2, capacitor C_1 continues to be discharged while C_2 starts charging.

Let at time t after shifting of switch to position 2, charge on capacitor C_2 be q and let current through the circuit be I .

\therefore Charge remaining on C_1 is equal to $(q_0 - q)$ as shown in Fig.

Applying Kirchoff's voltage law on the circuit shown in fig.

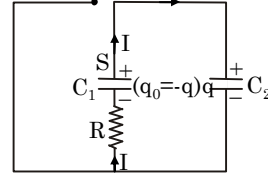

$$\frac{q}{C_2} + IR - \frac{(q_0 - q)}{C_1} = 0$$

$$\text{or } IR = \frac{q_0 - q}{C_1} - \frac{q}{C_2} = \frac{(q_0 C_2 - q C_2) - q C_1}{C_1 C_2}$$

But current, $I = \frac{dq}{dt}$ (Rate of increase of charge on C_2)

$$\therefore R \frac{dq}{dt} = \frac{q_0 C_2 - q(C_1 + C_2)}{C_1 C_2}$$

$$\text{or } \frac{dq}{q_0 C_2 - q(C_1 + C_2)} = \frac{dt}{RC_1 C_2}$$

But at $t = 0$, $q = 0$

$$\therefore \int_0^q \frac{dq}{q_0 C_2 - q(C_1 + C_2)} = \int_0^t \frac{dt}{RC_1 C_2}$$

From above equation,

$$q = \left(\frac{q_0 C_2}{C_1 + C_2} \right) \left[1 - e^{-\left(\frac{C_1 + C_2}{RC_1 C_2} \right) t} \right]$$

Substituting $q_0 = I_0 RC_1$,

$$q = I_0 \cdot \frac{RC_1 C_2}{C_1 + C_2} \left[1 - e^{-\left(\frac{C_1 + C_2}{RC_1 C_2} \right) t} \right]$$

But current, $I = \frac{dq}{dt}$

$$I = I_0 \cdot e^{-\left(\frac{C_1 + C_2}{RC_1 C_2} \right) t}$$

In steady state common potential difference across capacitors is given by

$$V = \frac{q_0 + 0}{C_1 + C_2} \quad \left(\text{using } V = \frac{C_1 V_1 + C_2 V_2}{C_1 + C_2} \right)$$

$$\text{or } V = \frac{I_0 RC_1}{C_1 + C_2}$$

Initially energy stored in C_1 was

$$U_1 = \frac{q_0^2}{2C_1} = \frac{1}{2} I_0^2 R^2 C_1$$

In steady state, energy stored in two capacitors is

$$\begin{aligned}
 U_2 &= \frac{1}{2} C_1 V^2 + \frac{1}{2} C_2 V^2 \\
 &= \frac{1}{2} (C_1 + C_2) \frac{I_0^2 R^2 C_1^2}{(C_1 + C_2)^2} \\
 &= \frac{I_0^2 R^2 C_1^2}{2(C_1 + C_2)}
 \end{aligned}$$

Heat generated across resistor R = Loss of energy stored in capacitors during redistribution of charge = $U_1 - U_2$

$$= \frac{I_0^2 R^2 C_1 C_2}{2(C_1 + C_2)}$$

Ex.11 In the circuit shown in Fig

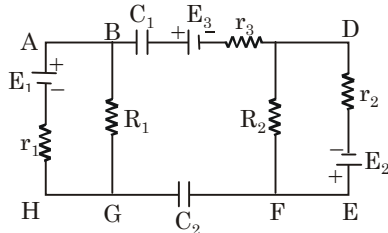

$R_1 = 8\Omega$, $R_2 = 5\Omega$, $C_1 = 6\mu\text{F}$, $C_2 = 3\mu\text{F}$, $E_1 = 5\text{V}$, $r_1 = 2\Omega$, $E_2 = 24\text{V}$, $r_2 = 3\Omega$, $E_3 = 14\text{V}$ and $r_3 = 2\Omega$.

Calculate charge on capacitors C_1 and C_2 in steady state.

Sol. In steady state, no current flows through capacitors, therefore, there are four unknown quantities in the given circuit :

- (i) current in left mesh ABGHA,
- (ii) current in right mesh CDEFC.
- (iii) charge q_1 on capacitor C_1 and
- (iv) charge q_2 on capacitor C_2 .

But by applying Kirchoff's voltage law three unique equations can be formed. It means that one more equation is required to analyse the circuit.

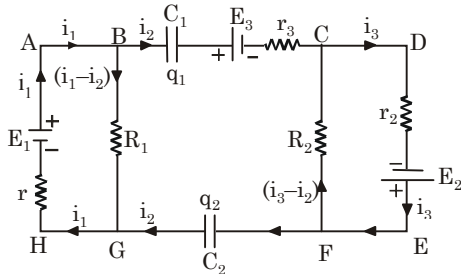

Considering the circuit at an instant when steady state was not reached and charges on capacitors were increasing. By applying Kirchoff's current law at junctions, it is found that currents through two capacitors were always identical as shown in fig. Hence, magnitudes q_1 and q_2 of charges on two capacitors are equal. Let it be q .

From directions of current in fig, it is clear that if left plate of capacitor C_1 is positively charged

then right plate of capacitor C_2 will be of the same polarity. Considering this fact, in steady state, circuit will be as shown in fig.

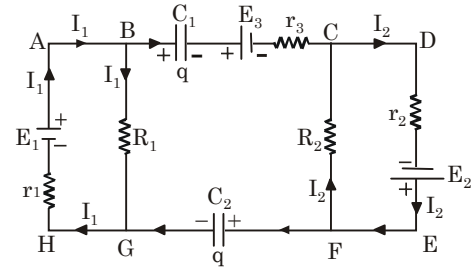

Applying Kirchoff's voltage law on mesh ABGHA,

$$I_1 R_1 + I_1 r_1 - E_1 = 0 \quad \text{or} \quad I_1 = 0.5 \text{ A}$$

For mesh, CDEFC, $I_1 r_2 - E_2 + I_2 R_2 = 0$

$$\text{or} \quad I_2 = 3 \text{ A}$$

Now applying Kirchoff's voltage law on mesh BCFGB,

$$+\frac{q}{C_1} + E_3 - I_2 R_2 + \frac{q}{C_2} - I_1 R_1 = 0, \quad q = 10\mu\text{C} \quad \text{Ans.}$$

Ex.12 A two way switch S is used in the circuit shown in fig. First, the capacitor is charged by putting the switch in position 1.

Calculate heat generated across each resistor when switch is in position 2.

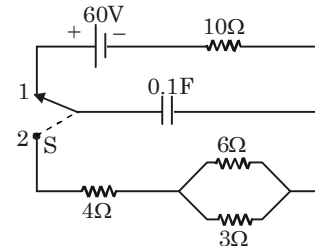

Sol. Initially the switch was in position 1. Therefore, initially potential difference across capacitors was equal to emf of the battery i.e. 60 volt

\therefore Initially energy stored in the capacitor was

$$U = \frac{1}{2} CV^2 = \frac{1}{2} \times 0.1 \times 60^2 \text{ J} = 180 \text{ J}$$

When switch is shifted to position 2, capacitor begins to discharge and energy stored in it is dissipated in the form of heat across resistances.

Let at some instant discharging current through the capacitor be i as shown in fig.

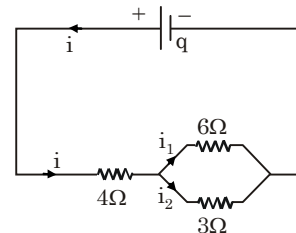

According to Kirchoff's laws,

$$i_1 + i_2 = i \quad \dots(1)$$

$$6i_1 - 3i_2 = 0$$

$$\text{or} \quad i_2 = 2i_1 \quad \dots(2)$$

From above two equations,

$$i_1 = \frac{i}{3}$$

and

$$i_2 = \frac{2}{3}i$$

But thermal power generated in a resistance R is $P = i^2 R$ where i is current flowing through it. Therefore, heat generated P_1 , P_2 and P_3 across 4Ω , 6Ω and 3Ω resistances is in ratio

$$4i_1^2 : 6i_2^2 : 3i_2^2$$

$$\text{or } P_1 : P_2 : P_3 = 4 : \frac{2}{3} : \frac{4}{3} = 6 : 1 : 2$$

But total heat generated is

$$P_1 + P_2 + P_3 = U$$

\therefore Heat generated across 4Ω is

$$P_1 = 120 \text{ J} \quad \text{Ans.}$$

Heat generated across 6Ω is

$$P_2 = 20 \text{ J} \quad \text{Ans.}$$

Heat generated across 3Ω is

$$P_3 = 40 \text{ J} \quad \text{Ans.}$$

Since, during discharging, no current flows through 10Ω , therefore heat generated across it is equal to zero. **Ans.**

Ex.13 In the circuit shown in fig., C is a parallel plate air capacitor having plates of area $A = 50 \text{ cm}^2$ each and a distance $d = 1 \text{ mm}$ apart. $R_1 : R_2$ and R_3 are resistors having resistances 3Ω , 2Ω and 1Ω respectively. Two identical sources each of emf V and of negligible internal resistance are connected as shown in fig. If dielectric strength of air is $E_0 = 3 \times 10^6 \text{ Vm}^{-1}$, calculate maximum safe value of V .

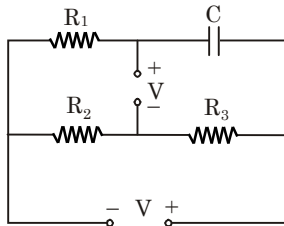

Sol. Due to sources, currents flow through resistance R_1 , R_2 and R_3 and capacitor gets charged. Due to charge, an electric field is established in the capacitor whose magnitude can not exceed dielectric strength E_0 of air.

Maximum safe value of V corresponds to maximum possible charge on capacitor. let maximum possible charge on capacitor be q_0

Then electric field inside the capacitor,

$$E_0 = \frac{q_0}{A\epsilon_0}$$

$$\text{or } q_0 = A\epsilon_0 E_0 = 15000 \epsilon_0 \text{ coulomb}$$

$$\text{and capacitance } C = \frac{\epsilon_0 A}{d} = 5\epsilon_0 \text{ Farad}$$

Since, in steady state no current flows through capacitor, therefore, current through various parts of the circuit will be as shown in fig.

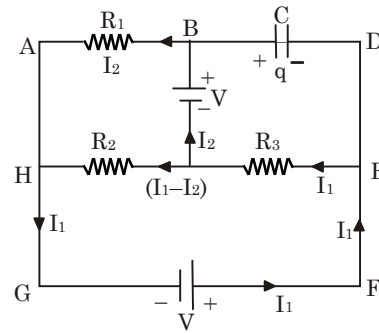

Now analysing the circuit in steady state, First, applying Kirchoff's voltage law on mesh ABJHA,

$$-I_2 R_1 + V + R_2 (I_1 - I_2) = 0$$

$$\text{or } 2I_1 - 5I_2 = -V \quad \dots(1)$$

For mesh HJEFHG,

$$-R_2 (I_1 - I_2) - R_3 I_1 + V = 0$$

$$\text{or } 3I_1 - 2I_2 = V \quad \dots(2)$$

From equations (1) and (2),

$$I_1 = \frac{7V}{11}$$

and

$$I_2 = \frac{5V}{11}$$

Now, applying Kirchoff's voltage law on mesh BDEJB,

$$\frac{q}{C} + I_1 R_3 - V = 0$$

$$\text{or } q = \frac{4CV}{11} = \frac{20}{11} \epsilon_0 V$$

But maximum possible value of q is

$$q_0 = 15000 \epsilon_0$$

$$\therefore \text{Maximum safe value of } V = \frac{11 q_0}{20 \epsilon_0}$$

$$= 8250 \text{ volts} = 8.25 \text{ kV}$$

Ans.

Ex.14 A variable capacitor is adjusted in position of its lowest capacitance C_0 and is connected with a source of constant voltage V for a long time. Resistance of connecting wires is R . At $t = 0$, its capacitance starts to increase so that a constant current I starts to flow through the circuit, Calculate at time t

- (i) power supplied by the source,
- (ii) thermal power generated in the connecting wires and
- (iii) rate of increase of electrostatic energy stored in capacitor.

(iv) What do you infer from above three results? **Sol.** Since, voltage V of the source is constant and circuit draws a constant current I from it, therefore, power supplied by the source is

$$P = V I \quad \text{Ans (i)}$$

Thermal power generated in connecting wires,

$$H = I^2 R \quad \text{Ans (ii)}$$

Since, initial capacitance of the capacitor was equal to C_0 and it was connected with the source for long time, therefore, initial charge on capacitor was equal to $q_0 = C_0 V$

Since a constant I starts to flow at $t = 0$ there fore, at time t , charge on capacitor becomes equal to $q = (C_0 V + It)$

At time t , circuit will be as shown in fig.

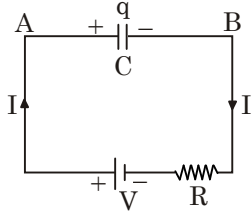

Potential difference across the capacitor is

$$V_C = V_A - V_B (V - IR)$$

\therefore Electronic energy in capacitor at this instant is

$$U = \frac{1}{2} qV_C$$

Rate of increase of electrostatic energy

$$\begin{aligned} \frac{dU}{dt} &= \frac{1}{2} V_C \frac{dq}{dt} = \frac{1}{2} (V - IR) \\ &= \frac{1}{2} (VI - I^2 R) \end{aligned}$$

Ans. (iii)

But power acting across the capacitor at this instant is $P_C = P - H = (VI - I^2 R)$ while rate of increase of electrostatic energy in capacitor is half of it.

In fact, a force of attraction exists between surfaces of the capacitor. When these surfaces move towards each other capacitance increases. Hence, remaining part of the power acting across capacitor is used to increase kinetic energy of surfaces (plates) of the capacitor.

Ans. (iv)

Ex.15 In the circuit shown in fig. $R_1 = 1\Omega$, $R_2 = 2\Omega$, $C_1 = 1\mu\text{F}$, $C_2 = 2\mu\text{F}$ and $E = 6\text{V}$. Calculate charge on each capacitor in steady state.

Sol. In steady state no current flows through capacitors. Therefore charge on each capacitor remains constant. Let, in steady state circuit draw a current I from battery and let charge on capacitors be q_1 and q_2 as shown in fig.

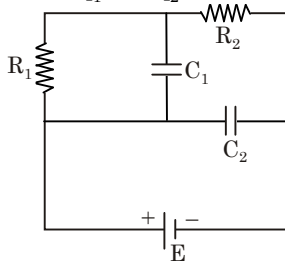

Applying Kirchoff's voltage law on mesh ABCDFGHA,

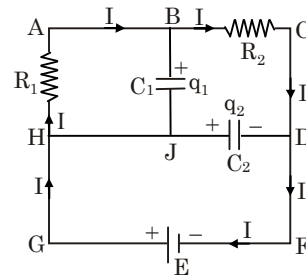

$$IR_2 - E + IR_1 = 0$$

$$\text{or} \quad I = \frac{E}{R_1 + R_2} = 2\text{A}$$

Now applying KVL on mesh ABJHA,

$$+ \frac{q_1}{C_1} + IR_1 = 0$$

$$\text{or} \quad q_1 = -2\mu\text{C}$$

(Negative sign indicates that the polarity of charge on capacitor C_1 is opposite to assume polarity. It means upper plate of the capacitor is negative while lower plate is positive).

Hence, magnitude of charge on $C_1 = 2\mu\text{C}$.

Now applying KVL on mesh HJDFGH,

$$+ \frac{q_2}{C_2} - E = 0$$

$$\text{or} \quad q_2 = C_2 E = 12\mu\text{C}$$

Ans.

Ex.16 Determine the value of ϵ , for which the power supplied to the 20Ω resistance in the figure is 180W ,

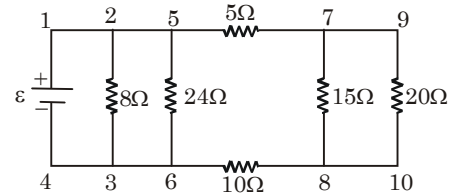

Sol.

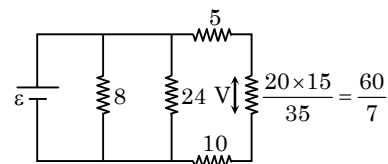

$$V = \frac{\frac{60}{7} \times \epsilon}{5 + \frac{60}{7} + 10};$$

$$V = \frac{60 \times \epsilon}{1.5}$$

$$\text{Heat} - \frac{V^2}{20} = 180$$

$$\text{or} \quad V = \sqrt{3600} = 60$$

$$\frac{60}{165} \epsilon = 60$$

$$\text{or} \quad \epsilon = 165\text{V}$$

EXERCISE (Level-1)

Questions based on

Current & Resistance definitio:

- Q.1** In copper, each copper atom releases one electron. If a current of 1.1 A is flowing in the copper wire of uniform cross-sectional area of diameter 1 mm, then drift velocity of electrons will approximately be-
(Density of copper = $9 \times 10^3 \text{ kg/m}^3$, Atomic weight of copper = 63)
(A) 10.3 mm/s (B) 0.1 mm/s
(C) 0.2 mm/s (D) 0.2 cm/s
- Q.2** A current of 5A exists in a 10Ω resistance for 4 minutes. The number of electrons and charge in coulombs passing through any section of the resistor in this time are -
(A) 75×10^{20} , 600C (B) 75×10^{21} , 600C
(C) 75×10^{20} , 1200C (D) 75×10^{19} , 1200C
- Q.3** A potential difference V exists between the ends of a metal wire of length ℓ . The drift velocity will be doubled if -
(A) V is doubled
(B) ℓ is doubled
(C) The diameter of the wire is doubled
(D) The temperature of the wire is doubled
- Q.4** The current in a conductor varies with time t is $I = 2t + 3t^2$ where I is in ampere and t in seconds. Electric charge flowing through a section of conductor during t = 2 sec to t = 3 sec. is -
(A) 10 C (B) 24 C (C) 33 C (D) 44 C
- Q.5** The current in a copper wire is increased by increasing the potential difference between its end. Which one of the following statements regarding n, the number of charge carriers per unit volume in the wire and v the drift velocity of the charge carriers is correct -
(A) n is unaltered but v is decreased
(B) n is unaltered but v is increased
(C) n is increased but v is decreased
(D) n is increased but v is unaltered
- Q.6** Consider two conducting wires of same length and material, one wire is solid with radius r. The other is a hollow tube of outer radius 2r while inner r. The ratio of resistance of the two wires will be -
(A) 1 : 1 (B) 1 : 2 (C) 3 : 1 (D) 1 : 4

Questions based on

Series & parallel combination of Resistance

- Q.7** Equivalent resistance between point C and D in the combination of resistance shown is -

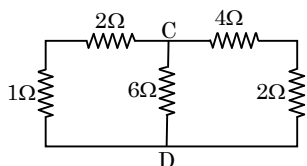

- (A) 3 Ω (B) 1 Ω (C) 1.5 Ω (D) 0.5 Ω

- Q.8** In the figure shown each resistor is of 20Ω and the cell has emf 10 volt with negligible internal resistance. Then rate of joule heating in the circuit is (in watts) -

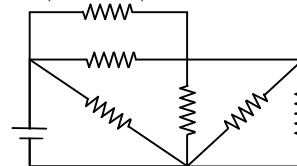

- (A) 100/11 (B) 10000/11
(C) 11 (D) None of these

- Q.9** Find the equivalent resistance between a & b

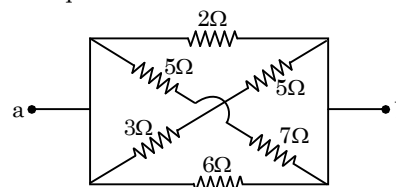

- (A) $\frac{7}{8} \Omega$ (B) $\frac{8}{7} \Omega$
(C) $\frac{6}{7} \Omega$ (D) $\frac{7}{6} \Omega$

- Q.10** The equivalent resistance between point A and B is -

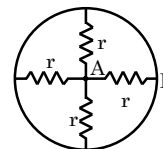

- (A) 4 r (B) 2r (C) r (D) $\frac{r}{4}$

- Q.11** A network of nine conductors connects six points A, B, C, D, E and F as shown below. The digits denote resistances in Ω . Find the equivalent resistance between B and C-

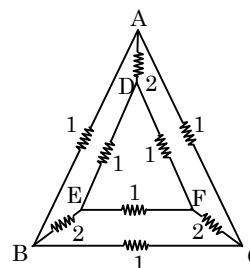

- (A) $\frac{2}{15} \Omega$ (B) $\frac{7}{12} \Omega$
(C) $\frac{5}{12} \Omega$ (D) $\frac{11}{12} \Omega$

- Q.12** Calculate the potential difference between points A and B and current flowing through the $10\ \Omega$ resistor in the part of the network below -

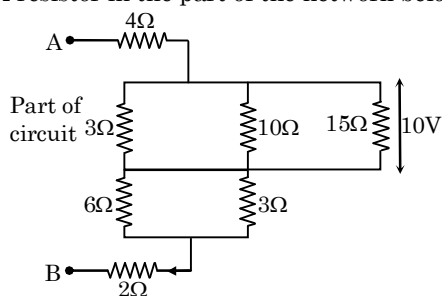

- (A) 20 V, 2A (B) 50 V, 1A
(C) 40 V, 1A (D) 30 V, 1A

- Q.13** In the given circuit, it is observed that the current I is independent of the value of the resistance R_6 . Then the resistance values must satisfy -

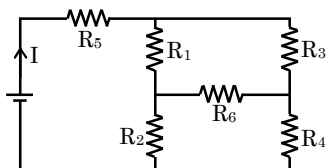

- (A) $R_1 R_2 R_5 = R_3 R_4 R_6$
(B) $\frac{1}{R_5} + \frac{1}{R_6} = \frac{1}{R_1 + R_2} + \frac{1}{R_3 + R_4}$
(C) $R_1 R_4 = R_2 R_3$
(D) $R_1 R_3 = R_2 R_4 = R_5 R_6$

- Q.14** Two wires of equal diameters of resistivities ρ_1 and ρ_2 and lengths x_1 and x_2 are joined in series. The equivalent resistivity of the combination is -

- (A) $\frac{\rho_1 x_1 + \rho_2 x_2}{x_1 + x_2}$ (B) $\frac{\rho_1 x_2 - \rho_2 x_1}{x_1 - x_2}$
(C) $\frac{\rho_1 x_2 + \rho_2 x_1}{x_1 + x_2}$ (D) $\frac{\rho_1 x_1 + \rho_2 x_2}{\rho_1 + \rho_2}$

- Q.15** In the circuit shown in the figure, equivalent resistance is maximum -

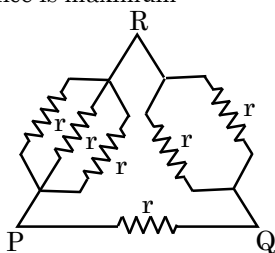

- (A) Between P & Q
(B) Between P & R
(C) Between R & P
(D) Same between all the points

- Q.16** The length of a given cylindrical wire is increased by 100%. Due to the consequent decrease in diameter the change in the resistance of the wire will be -
(A) 100% (B) 50% (C) 300% (D) 200%

Questions based on

Kirchoff Law : Power, Energy, Battery, EMF, Terminal voltage

- Q.17** For driving a current of 3 ampere for 5 minutes in an electrical circuit, 900 joule of work is to be done. Find the emf of the source in the circuit.
(A) 2 Volt (B) 3 Volt (C) 1 Volt (D) 5 Volt

- Q.18** The current I in the circuit shown in the figure is -

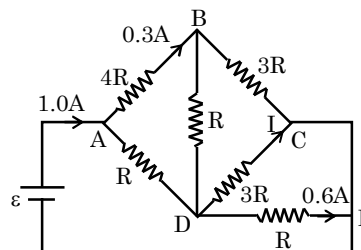

- (A) 0 (B) 0.1 A (C) 0.4 A (D) 0.2 A

- Q.19** In the circuit shown in figure the value of R is -

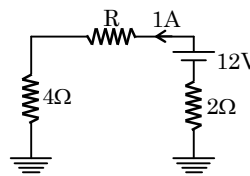

- (A) 8 Ω (B) 6 Ω (C) 10 Ω (D) 12 Ω

- Q.20** In the circuit, the value of R is so chosen that thermal power generated in it is maximum, then value of R is -

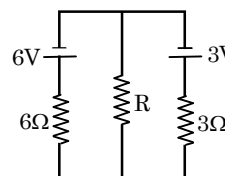

- (A) 2 Ω (B) 3 Ω (C) 6 Ω (D) 9 Ω

- Q.21** Find out current in $2\ \Omega$ resistance ?

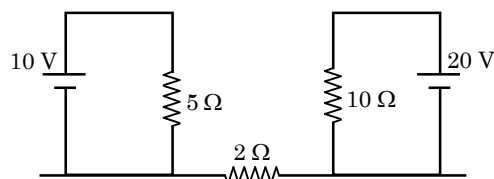

- (A) 0 (B) 2 A (C) 3 A (D) 5 A

- Q.22** An electric kettle has two coils. When one coil is switched on it takes 15 minutes to boil water and when the second coil is switched on, it takes 30 minutes. How long will it take to boil water when both the coils are used in (i) series and (ii) parallel ?
(A) 10 min, 45 min (B) 45 min, 10 min
(C) 30 min, 10 min (D) 20 min, 45 min

- Q.23** If energy consumption of this circuit is 150 watt then find the value of resistance –

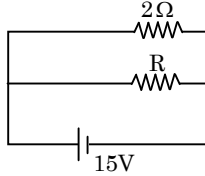

- (A) $2\ \Omega$ (B) $4\ \Omega$ (C) $6\ \Omega$ (D) $8\ \Omega$

Questions based on Instruments

- Q.24** A, B and C are voltmeters of resistances R , $1.5R$ and $3R$ respectively. When some potential difference is applied between X and Y, the voltmeter readings are V_A , V_B and V_C respectively -

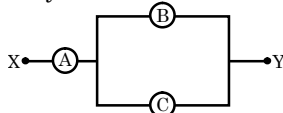

- (A) $V_A = V_B = V_C$ (B) $V_A \neq V_B = V_C$
 (C) $V_A = V_B \neq V_C$ (D) $V_B \neq V_A = V_C$

- Q.25** In the circuit, each resistance is $20\ \Omega$. The readings of A_1 , A_2 and A_3 are respectively - (all ammeters are ideal)

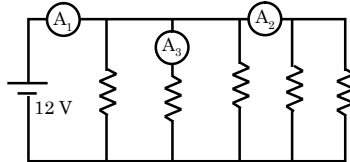

- (A) 3A, 1.8A, 1.2 A (B) 3A, 1.2 A, 0.6A
 (C) 3A, 0.6 A, 1.2 A (D) 3A, 0.6 A, 0.6 A

- Q.26** In the electric circuit shown in figure, the reading of voltmeter V_1 is 26 volt, and the reading of ammeter A_1 is 2 ampere. The value of resistance x is - (all instruments are ideal)

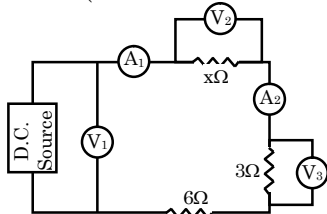

- (A) $2\ \Omega$ (B) $4\ \Omega$ (C) $6\ \Omega$ (D) $8\ \Omega$

- Q.27** In the figure, the potentiometer wire AB of length L and resistance $9r$ is joined to the cell D of emf ϵ and internal resistance r . The cell C's emf is $\epsilon/2$ and its internal resistance is $2r$. The galvanometer G will show no deflection when the length AJ is-

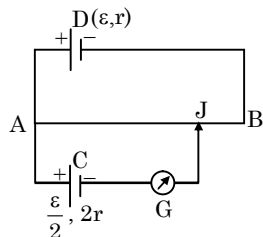

- (A) $\frac{4L}{9}$ (B) $\frac{5L}{9}$ (C) $\frac{7L}{18}$ (D) $\frac{11L}{18}$

- Q.28** In the circuit shown the variable resistance R_h is so adjusted that ammeter reads the same in both positions of the key. The reading of ammeter is I . The emf of the cell in series with x is E , the value of x is -

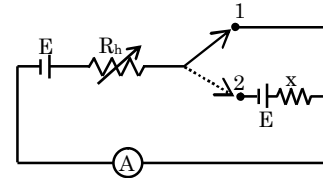

- (A) $\frac{2E}{I}$ (B) $\frac{E}{I}$ (C) EI (D) $2EI$

- Q.29** A potentiometer wire AB is 100 cm long and has a total resistance of 10 ohm. If the galvanometer shows zero deflection at the position C, then find the value of unknown resistance R .

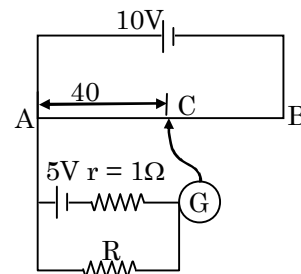

- (A) $2\ \Omega$ (B) $4\ \Omega$ (C) $6\ \Omega$ (D) $8\ \Omega$

- Q.30** If the reading of ammeter A_1 in figure is 2.4 A, what will the ammeter A_2 and A_3 read? (Neglecting the resistances of ammeters) -

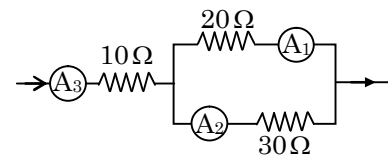

- (A) 1.6 A, 2.3 A (B) 1.6 A, 4.0 A
 (C) 4.0 A, 1.6 A (D) 2.3 A, 1.6 A

- Q.31** A potentiometer experiment is setup as shown in figure. If both the galvanometer shows null deflections for the sliding contacts at x and y as shown then -

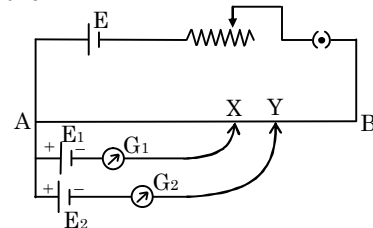

- (A) $E_1 = E_2$ (B) $E_1 > E_2$
 (C) $E_1 < E_2$ (D) none of the above

- Q.32** In this given circuit, no current is passing through the galvanometer. If the cross-sectional diameter of the wire AB is doubled then for null point of galvanometer the value of AC would be -

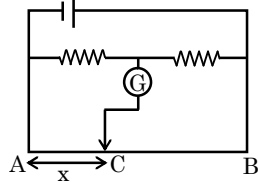

- (A) $x/4$ (B) $4x$ (C) $2x$ (D) x

- Q.33** Which of the following circuit is correct for verification of ohms law -

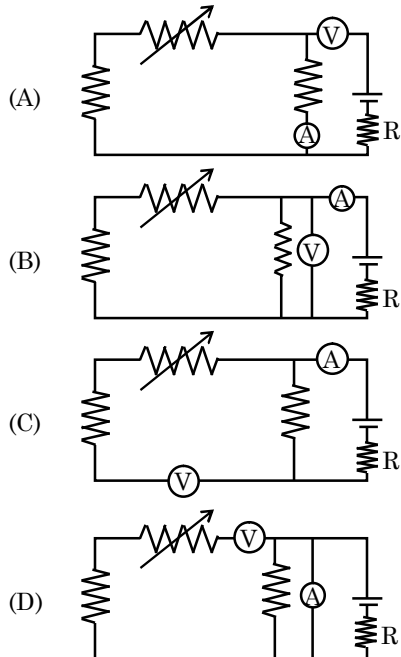

- Q.34** In the figure shown for gives of R_1 and R_2 the balance point for Jockey is at 40 cm from A. When R_2 is shunted by a resistance of 10Ω , balance shifts to 50 cm. R_1 and R_2 are ($AB = 1 \text{ m}$)-

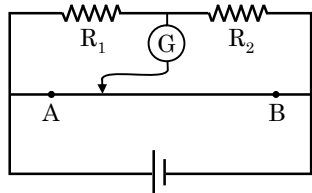

- (A) $\frac{10}{3} \Omega, 5 \Omega$ (B) $20 \Omega, 30 \Omega$
 (C) $10 \Omega, 15 \Omega$ (D) $5 \Omega, \frac{15}{2} \Omega$

Questions based on

Standard rating / Heat generation definition

- Q.35** A bulb is made using two filaments. A switch selects whether the filaments are used individually or in parallel. When this bulb is used with a 15 volt battery, the bulb can

developed 5W, 10W, or 15W power. Then resistances of filaments should be -

- (A) $10 \Omega, 20 \Omega$ (B) $22.5 \Omega, 22.5 \Omega$
 (C) $22.5 \Omega, 45 \Omega$ (D) $45 \Omega, 90 \Omega$

- Q.36** A cell of constant emf produces the same amount of heat during the same time in two independent resistors R_1 and R_2 when they are separately connected across the terminals of the cell, one after another. The internal resistance of the cell is -

- (A) $\frac{R_1 + R_2}{2}$ (B) $\sqrt{R_1 R_2}$
 (C) $\frac{|R_1 - R_2|}{2}$ (D) $\frac{R_1 R_2}{R_1 + R_2}$

- Q.37** If X, Y, and Z in figure are identical lamps, which of the following changes to the brightnesses of the lamps occur when switch S is closed ?

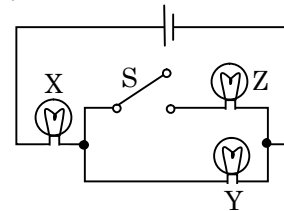

- (A) X stays the same, Y decreases
 (B) X increases, Y decreases
 (C) X increases, Y stays the same
 (D) X decreases, Y increases

Questions based on

Capacitor in circuit

- Q.38** A battery of emf V volt, resistance R_1 and R_2 , a capacitance C and switches S_1 and S_2 are connected in an electrical circuit as shown in figure. The capacitor C gets fully charged to V volt when -

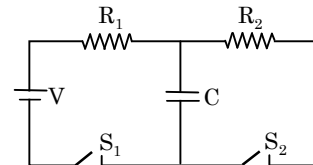

- (A) S_1 and S_2 are both closed
 (B) S_1 and S_2 are both open
 (C) S_1 closed and S_2 open
 (D) S_2 closed and S_1 open

- Q.39** In the circuit shown in figure, how does brightness of the bulb change with time after the switch S is closed ? Assume that the capacitance and it is initially uncharged -

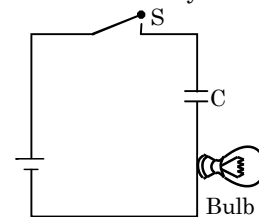

- (A) brightness increases with time and becomes constant after a certain time
- (B) brightness decreases with time and reduces to zero after some time
- (C) brightness increases, becomes constant and then again increases due to the discharging of capacitor
- (D) brightness is constant till the capacitor is fully charged and then it increases because the whole current is now available to the bulb

Q.40 When the key K is pressed at time $t = 0$ which of the following statements about the current I in the resistor AB of the given circuit is true -

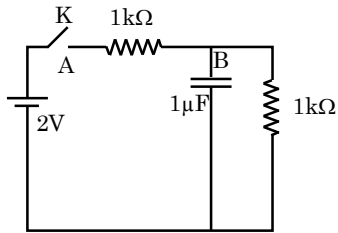

- (A) $I = 2 \text{ mA}$ at all t
- (B) I oscillates between 1 mA and 2 mA
- (C) $I = 1 \text{ mA}$ at all t
- (D) At $t = 0$, $I = 2 \text{ mA}$ and with time it goes to 1 mA

Q.41 In fig. shown, when switch S is closed, what will be the voltage across capacitor $2 \mu\text{F}$ and $1 \mu\text{F}$ capacitor. (consider steady state condition)

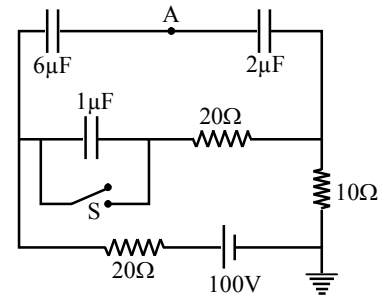

- (A) $20\text{V}, 0$
- (B) $40\text{V}, 0$
- (C) $30\text{V}, 0$
- (D) $10\text{V}, 0$

Q.42 In the given circuit, with steady current, the potential drop across the capacitor must be -

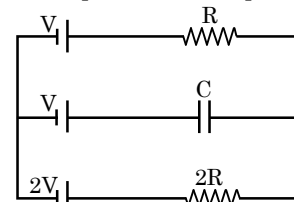

- (A) V
- (B) $V/2$
- (C) $V/3$
- (D) $2V/3$

EXERCISE (Level-2)

Single correct answer type questions

Q.1 A carbon and an aluminium wire connected in series. If the combination has resistance of 30 ohm at 0°C , what is the resistance of carbon and aluminium wire at 0°C so that the resistance of the combination does not change with temperature - [$\alpha_c = -0.5 \times 10^{-3} (\text{C}^\circ)^{-1}$ and $\alpha_{Al} = 4 \times 10^{-3} (\text{C}^\circ)^{-1}$]

- (A) $\frac{10}{3} \Omega, \frac{80}{3} \Omega$ (B) $\frac{80}{3} \Omega, \frac{10}{3} \Omega$
 (C) $10 \Omega, 80 \Omega$ (D) $80 \Omega, 10 \Omega$

Q.2 An infinite ladder network of resistance is constructed with 1Ω and 2Ω resistance. The 6V battery between A and B has negligible internal resistance. The current that passes through 2Ω resistance nearest to the battery is -

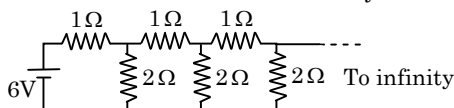

- (A) 1A (B) 1.5 A (C) 2 A (D) 2.5 A

Q.3 The emf of the battery shown in the figure is given by -

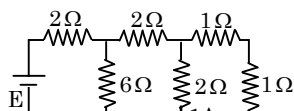

- (A) 6 V (B) 12 V (C) 18 V (D) 8 V

Q.4 In the given figure the ratio of current in 8Ω and 3Ω will be -

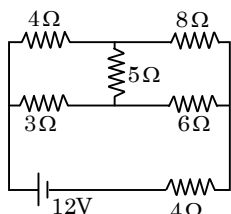

- (A) $\frac{8}{3}$ (B) $\frac{3}{8}$ (C) $\frac{4}{3}$ (D) $\frac{3}{4}$

Q.5 In figure the steady state voltage drop across capacitor (C) is -

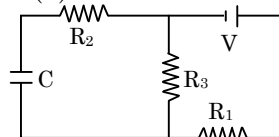

- (A) V (B) $\frac{VR_1}{R_3 \left(\frac{R_1 \cdot R_3}{R_1 + R_3} \right)}$
 (C) $\frac{VR_3}{R_1 + R_3}$ (D) $\frac{VR_1}{R_1 + R_3}$

Q.6 A 100 W bulb B_1 , and two 60 W bulbs B_2 and B_3 , are connected to a 250 V source, as shown in the figure. Now W_1 , W_2 and W_3 are the output powers of the bulbs B_1 , B_2 and B_3 , respectively. (Rated potential of each bulb is 250 V) select correct alternative -

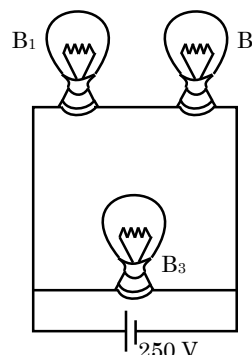

- (A) $W_1 > W_2 = W_3$ (B) $W_1 > W_2 > W_3$
 (C) $W_1 < W_2 = W_3$ (D) $W_1 < W_2 < W_3$

Q.7 In the fig below the bulbs are identical, which bulb(s), light(s) most brightly ?

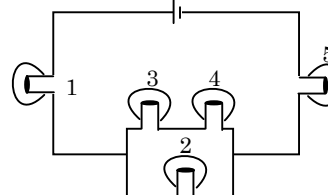

- (A) 1 only (B) 4 only (C) 2 and 3 (D) 1 and 5

Q.8 The effective resistance between points P and Q of the electrical circuit shown in the figure is -

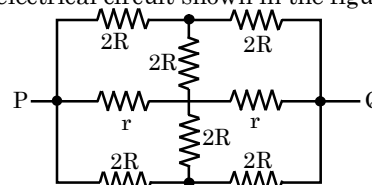

- (A) $\frac{2Rr}{R+r}$ (B) $\frac{8R(R+r)}{3R+r}$
 (C) $2r+4R$ (D) $\frac{5R}{2+2r}$

Q.9 A long resistance wire is divided into $2n$ parts. Then n parts are connected in series and the other n parts in parallel separately. Both combinations are connected to identical supplies. Then the ratio of heat produced in series to parallel combinations will be -

- (A) 1 : 1 (B) 1 : n^2 (C) 1 : n^4 (D) n^2 : 1

Q.10 In a potentiometer experiment it is found that no current pass through the galvanometer when the terminals of the cell are connected across 125 cm of potentiometer wire. On shunting the cell by a 2Ω resistance the balancing length reduces to half. The internal resistance of the cell is -

- (A) 4 Ω (B) 2 Ω (C) 1 Ω (D) 0.5 Ω

Q.11 Arrange the order of power dissipated in the given circuits, if the same current is passing through all the circuits. The resistance of each resistor is 'r' -

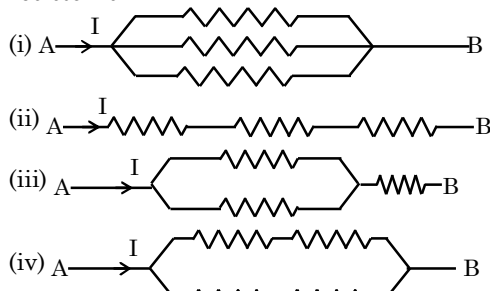

- (A) $P_2 > P_3 > P_4 > P_1$ (B) $P_1 > P_4 > P_2 > P_3$
 (C) $P_3 > P_1 > P_4 > P_2$ (D) $P_2 > P_4 > P_1 > P_3$

Q.12 A capacitor is charged using an external battery with a resistance x in series. The dashed line shows the variation of $\log_e I$ with respect to time. If the resistance is changed to $2x$, the new graph will be -

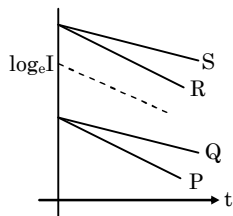

- (A) P (B) Q (C) R (D) S

Q.13 The length of a wire of a potentiometer is 100 cm, and the e.m.f. of its standard cell is E volt. It is employed to measure the e.m.f. of battery whose internal resistance is 0.5Ω . If the balance point is obtained at $\ell = 30$ cm from the positive end the e.m.f. of the battery is -

- (A) $\frac{30E}{(100 - 0.5)}$
 (B) $\frac{30(E - 0.5i)}{(100)}$, where i is the current in the potentiometer wire
 (C) $\frac{30E}{100}$
 (D) $\frac{30E}{100.5}$

Q.14 An ammeter reads upto 1 ampere. Its internal resistance is 0.81 ohm . To increase the range to 10A the value of the required shunt is -
 (A) 0.3Ω (B) 0.9Ω (C) 0.09Ω (D) 0.03Ω

Q.15 The total current supplied to the circuit by the battery is -

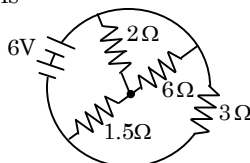

- (A) 1 A (B) 2 A (C) 4 A (D) 6 A

Q.16 The resistance of the series combination of two resistance is S . When they are joined in parallel the total resistance is P . If $S = nP$ then the minimum possible value of n is -
 (A) 4 (B) 3 (C) 2 (D) 1

Q.17 An electric current is passed through a circuit containing two wires of the same material, connected in parallel. If the lengths and radii of the wires are in the ratio of $4/3$ and $2/3$, then the ratio of the currents passing through the wires will be -
 (A) 3 (B) $1/3$ (C) $8/9$ (D) 2

Q.18 When a galvanometer is shunted with a 4Ω resistance, the deflection is reduced to one-fifth. If the galvanometer is further shunted with a 2Ω wire, the deflection will be (The main current remains the same) -
 (A) $(8/13)$ of the original deflection only
 (B) $(5/13)$ of the original deflection
 (C) $(3/4)$ of the deflection when shunted with 4Ω only
 (D) $(5/13)$ of the deflection when shunted with 4Ω only

Q.19 In the circuit shown in figure, the emf and internal resistance of the battery are E and r . R_1 and R_2 are two resistance of fixed resistance. As the side of variable resistor R moves towards A, the current I_1 through R_1 and current I_2 through R_2 change as follows-

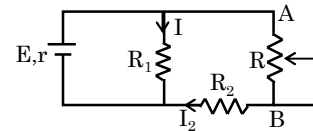

- (A) I_1 increases, I_2 decreases
 (B) I_1 increases, I_2 increases
 (C) I_1 decreases, I_2 increases
 (D) I_1 decreases, I_2 decreases

Q.20 For the circuit shown in figure the ratio of the amounts of heat liberated per unit time in conductors 1-2 and 3-4 is -

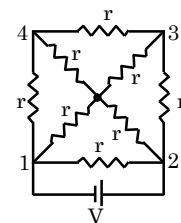

- (A) 1 : 16 (B) 16 : 1 (C) 8 : 1 (D) 1 : 8

Q.21 The charge supplied by source varies with time t as $Q = at - bt^2$. The total heat produced in resistor $2R$ is : (Assume direction of current is not changing)

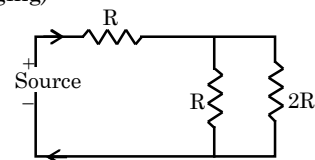

- (A) $\frac{a^3 R}{6b}$ (B) $\frac{a^3 R}{27b}$
 (C) $\frac{a^3 R}{3b}$ (D) None of these

- Q.22** ABCD is a square of side 1 metre where each side is a uniform wire of resistance 1Ω . A point E lies on CD such that if a uniform wire of resistance 1Ω is connected across AE and constant potential difference is applied across A and C then B and E are equipotential then select correct option B -

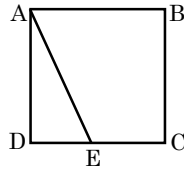

- (A) $\frac{CE}{ED} = 1$ (B) $\frac{CE}{ED} = 2$
 (C) $\frac{CE}{ED} = \frac{1}{\sqrt{2}}$ (D) $\frac{CE}{ED} = \sqrt{2}$

- Q.23** The magnitude of saturation charge on capacitor of capacitance C is -

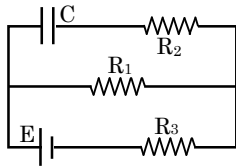

- (A) CE (B) $\frac{CER_1}{R_1 + R_3}$
 (C) $\frac{CER_2}{R_1 + R_3}$ (D) $\frac{CER_1}{R_2 + R_3}$

- Q.24** The value of resistance as measured across terminals A and B in figure would be : (Assume steady state)

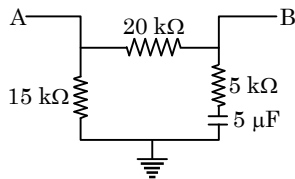

- (A) $20\text{ k}\Omega$ (B) $10\text{ k}\Omega$ (C) $15\text{ k}\Omega$ (D) $5\text{ k}\Omega$

- Q.25** In circuit, if no current flows through the galvanometer when the key K is closed, the bridge is balanced. The balancing condition for bridge is -

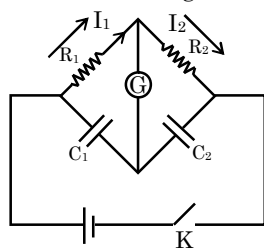

- (A) $\frac{C_1}{C_2} = \frac{R_1}{R_2}$ (B) $\frac{C_1}{C_2} = \frac{R_2}{R_1}$
 (C) $\frac{C_1^2}{C_2^2} = \frac{R_1^2}{R_2^2}$ (D) $\frac{C_1^2}{C_2^2} = \frac{R_2^2}{R_1^2}$

- Q.26** A capacitor is charged by connecting a battery of emf E and internal resistance r, at $t = 0$. If at an instant t, potential difference across the capacitor be V and heat generated upto that instant be H, then which of the following graphs is correct -

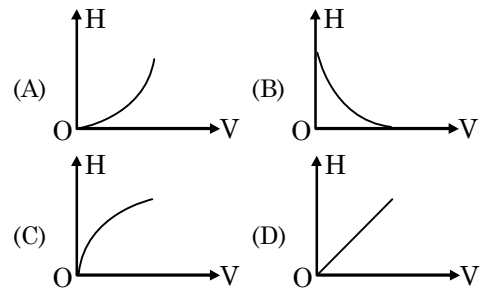

- Q.27** Two current elements P and Q have current voltage characteristics as shown below -

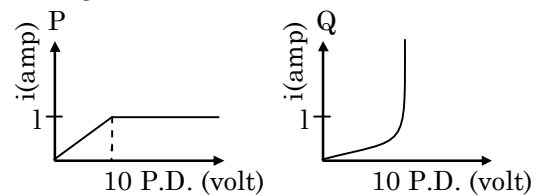

Which of the graphs given below represents current voltage characteristics when P and Q are in series-

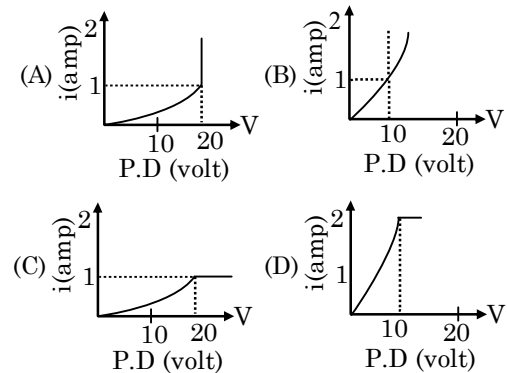

- Q.28** In the arrangement shown in figure when the switch S_2 is open, the galvanometer shows no deflection for $\ell = L/2$. When the switch S_2 is closed, the galvanometer shows no deflection for $\ell = 5L/12$. The internal resistance (r) of 6 V cell, and the emf E of the other battery are respectively-

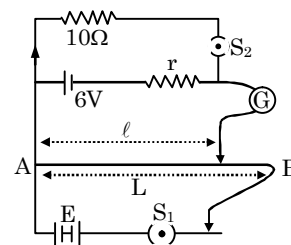

- (A) $3\Omega, 8\text{V}$ (B) $2\Omega, 12\text{V}$
 (C) $2\Omega, 24\text{V}$ (D) $3\Omega, 12\text{V}$

- Q.29** In the circuit shown in figure reading of ideal voltmeter is V_1 when only S_1 is closed, reading of ideal voltmeter is V_2 when only S_2 is closed and reading of this voltmeter is V_3 when both S_1 and S_2 are closed. Then -

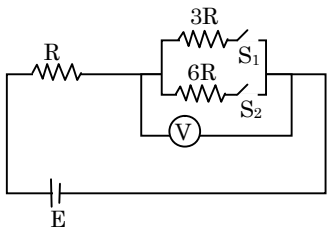

- (A) $V_3 > V_2 > V_1$ (B) $V_2 > V_1 > V_3$
 (C) $V_3 > V_1 > V_2$ (D) $V_1 > V_2 > V_3$

- Q.30** In the circuit shown in figure $C_1 = 2C_2$. Switch S is closed at time $t = 0$. Let i_1 and i_2 be the currents flowing through C_1 and C_2 at any time t , then the ratio i_1/i_2 -

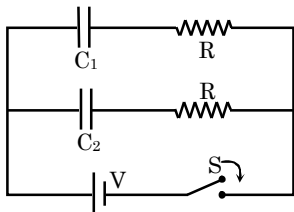

- (A) is constant
 (B) increases with increase in time t
 (C) decreases with increase in time t
 (D) first increases then decreases

- Q.31** In the circuit shown, the cell is ideal, with emf = 15 V. Each resistance is of 3Ω . The potential difference across the capacitor is -

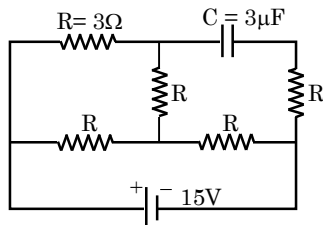

- (A) zero (B) 9 V (C) 12 V (D) 15 V

- Q.32** A charged capacitor is allowed to discharge through a resistor by closing the key at the instant $t = 0$. At the instant $t = (\ln 4) \mu\text{s}$, the reading of the ammeter falls half the initial value. The resistance of the ammeter is equal to -

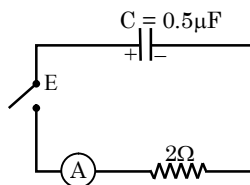

- (A) 1 MΩ (B) 1 Ω (C) 2 Ω (D) 2 MΩ

- Q.33** An ammeter A of finite resistance, and a resistor R are joined in series to an ideal cell C. A potentiometer P is joined in parallel to R. The ammeter reading is I_0 and the potentiometer reading is V_0 . P is now replaced by a voltmeter of finite resistance. The ammeter reading now is I and the voltmeter reading is V -

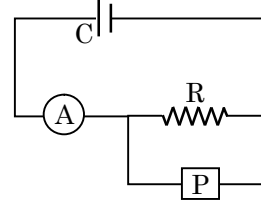

- (A) $I > I_0, V < V_0$ (B) $I > I_0, V = V_0$
 (C) $I = I_0, V < V_0$ (D) $I < I_0, V = V_0$

- Q.34** The diagram beside shows a circuit used in an experiment to determine the emf and internal resistance of the cell C. A graph was plotted of the potential difference V between the terminals of the cell against the current I, which was varied by adjusting the rheostat. The graph is shown on the right; x and y are the intercepts of the graph with the axes as shown. What is the internal resistance of the cell ?

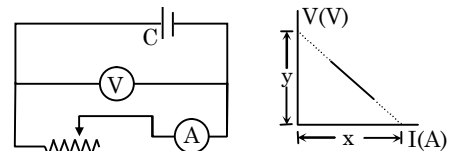

- (A) x (B) y (C) x/y (D) y/x

- Q.35** In the circuit shown, the resistance are given in ohms and the battery is assumed ideal with emf equal to 3.0 volts. The resistor that dissipates the most power is -

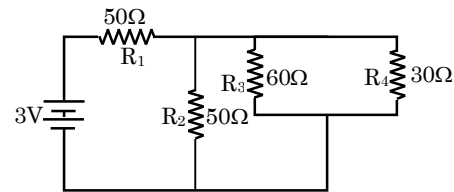

- (A) R_1 (B) R_2 (C) R_3 (D) R_4

- Q.36** The length of a potentiometer wire is l . A cell of emf E is balanced at a length $l/3$ from the positive end of the wire. If the length of the wire is increased by $l/2$. At what distance will the same cell give a balance point -

- (A) $\frac{2l}{3}$ (B) $\frac{l}{2}$ (C) $\frac{l}{6}$ (D) $\frac{4l}{3}$

- Q.37** A heater A gives out 300 W of heat when connected to a 200 V d.c. supply. A second heater B gives out 600 W when connected to a 200 V d.c. supply. If a series combination of the two heaters is connected to a 200 V d.c. supply the heat output will be -

- (A) 100 W (B) 450 W (C) 300 W (D) 200 W

Q.38 The current through the 8Ω resistor (shown in fig.) is -

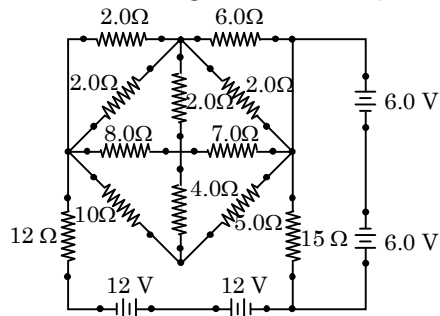

- (A) 4A (B) 2A
(C) zero (D) 2.5 A

Q.39 The current enters at A and comes out at D. Some of the resistances are shown. What should be resistance of wire CB so that it draws double of the current that enters the wire BF.

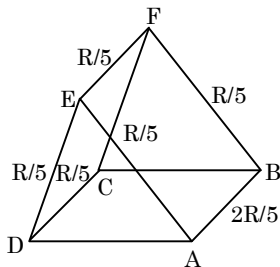

- (A) $\left(\frac{9}{10}\right)R$ (B) $\left(\frac{8}{9}\right)R$
(C) $\left(\frac{7}{9}\right)R$ (D) $\left(\frac{3}{20}\right)R$

Q.40 Sixteen resistor, each of resistance 16Ω , are connected in the circuit as shown in figure. The net resistance between A and B is -

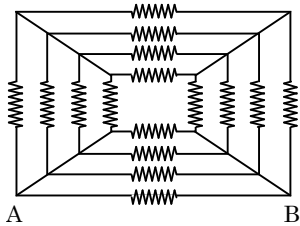

- (A) 1Ω (B) 2Ω (C) 3Ω (D) 4Ω

Q.41 For the circuit shown in figure, the equivalent resistance between A and C is -

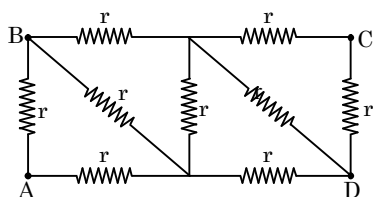

- (A) $\frac{12}{11}r$ (B) $\frac{13}{11}r$ (C) $\frac{14}{11}r$ (D) $\frac{15}{11}r$

Q.42 The potential difference across the 100Ω resistance in the following circuit is measured by a voltmeter of 900Ω resistance. The percentage error made in reading the potential difference is -

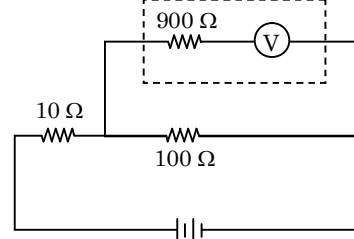

- (A) $\frac{10}{9}$ (B) 0.1 (C) 1.0 (D) 10.0

Q.43 Two resistances of 400Ω and 800Ω are connected in series with $6V$ battery of negligible internal resistance. A voltmeter of resistance 10000Ω is used to measure the potential difference across 400Ω . The error in the measurement of potential difference in volts approximately is -

- (A) 0.01 (B) 0.02 (C) 0.03 (D) 0.05

Q.44 The ammeter has range I ampere without shunt. The range can be varied by using different shunt resistance. The graph between shunt resistance and range will have the nature -

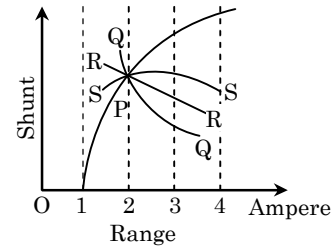

- (A) P (B) Q (C) R (D) S

EXERCISE (Level-3)

Old Examination Questions [JEE Main]

Q.1 A moving coil galvanometer has 150 equal divisions. Its current sensitivity is 10 divisions per milliampere and voltage sensitivity is 2 divisions per millivolt. In order that each division reads 1 volt, the resistance in ohms needed to be connected in series with the coil will be -

[AIEEE-2005]

- (A) 10^3 (B) 10^5 (C) 99995 (D) 9995

Q.2 In the circuit, the galvanometer G shows zero deflection. If the batteries A and B have negligible internal resistance, the value of the resistor R will be -

[AIEEE-2005]

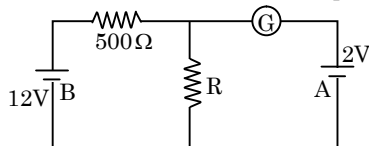

- (A) 200 Ω (B) 100 Ω (C) 500 Ω (D) 1000 Ω

Q.3 Two sources of equal emf are connected to an external resistance R. The internal resistances of the two sources are R_1 and R_2 ($R_2 > R_1$). If the potential difference across the source having internal resistance R_2 is zero, then -

[AIEEE-2005]

- (A) $R = R_2 \times (R_1 + R_2) / (R_2 - R_1)$
 (B) $R = R_2 - R_1$
 (C) $R = R_1 R_2 / (R_1 + R_2)$
 (D) $R = R_1 R_2 / (R_2 - R_1)$

Q.4 An energy source will supply a constant current into the load if its internal resistance is -

[AIEEE-2005]

- (A) equal to the resistance of the load
 (B) very large as compared to the load resistance
 (C) zero
 (D) non-zero but less than the resistance of the load

Q.5 In a potentiometer experiment the balancing with a cell is at length 240 cm. On shunting the cell with a resistance of 2 Ω, the balancing length becomes 120 cm. The internal resistance of the cell is -

[AIEEE-2005]

- (A) 1 Ω (B) 0.5 Ω (C) 4 Ω (D) 2 Ω

Q.6 A material 'B' has twice the specific resistance of 'A'. A circular wire made of 'B' has twice the diameter of a wire made of 'A'. Then for the two wires to have the same resistance, the ratio ℓ_B / ℓ_A of their respective lengths must be -

[AIEEE-2006]

- (A) $\frac{1}{4}$ (B) 2 (C) 1 (D) $\frac{1}{2}$

Q.7 The Kirchhoff's first law ($\sum i = 0$) and second law ($\sum iR = \sum E$), where the symbols have usual meanings, are respectively based on -

[AIEEE-2006]

- (A) conservation of momentum, conservation of charge
 (B) conservation of charge, conservation of energy
 (C) conservation of charge, conservation of momentum
 (D) conservation of energy, conservation of charge

Q.8 The current I drawn from the 5 volt source will be -

[AIEEE-2006]

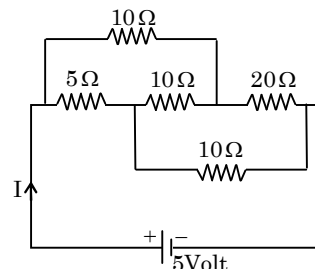

- (A) 0.67 A (B) 0.17 A (C) 0.33 A (D) 0.5 A

Q.9 In a Wheatstone's bridge, three resistances P, Q and R are connected in the three arms and the fourth arm is formed by two resistances S_1 and S_2 connected in parallel. The condition for the bridge to be balance will be -

[AIEEE-2006]

- (A) $\frac{P}{Q} = \frac{R(S_1 + S_2)}{2S_1 S_2}$ (B) $\frac{P}{Q} = \frac{R}{S_1 + S_2}$
 (C) $\frac{P}{Q} = \frac{2R}{S_1 + S_2}$ (D) $\frac{P}{Q} = \frac{R(S_1 + S_2)}{S_1 S_2}$

Q.10 An electric bulb is rated 220 volt – 100 watt. The power consumed by it when operated on 110 volt will be -

[AIEEE-2006]

- (A) 25 watt (B) 50 watt
 (C) 75 watt (D) 40 watt

Q.11 The resistance of wire is 5 ohm at 50°C and 6 ohm at 100°C. The resistance of the wire at 0°C will be -

[AIEEE-2007]

- (A) 2 ohm (B) 1 ohm (C) 4 ohm (D) 3 ohm

Q.12 A 5 V battery with internal resistance 2 Ω and a 2V battery with internal resistance 1Ω are connected to a 10Ω resistor as shown in the figure.

[AIEEE-2008]

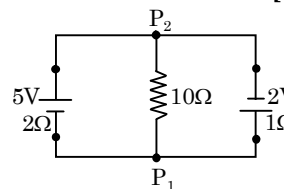

The current in the 10 Ω resistor is -

- (A) 0.03 A P_1 to P_2 (B) 0.03 A P_2 to P_1
 (C) 0.27 A P_1 to P_2 (D) 0.27 A P_2 to P_1

Passage : (Q.13 & 14)

Consider a block of conducting material of resistivity ' ρ ' shown in the figure. Current ' I ' enters at 'A' and leaves from 'D'. We apply superposition principle to find voltage ' ΔV ' developed between 'B' and 'C'. The calculation is done in the following steps : [AIEEE-2008]

- Take current ' I ' entering from 'A' and assume it to spread over a hemispherical surface in the block.
- Calculate field $E(r)$ at distance ' r ' from A by using Ohm's law $E = \rho j$, where j is the current per unit area at ' r '.
- From the ' r ' dependence of $E(r)$, obtain the potential $V(r)$ at r .

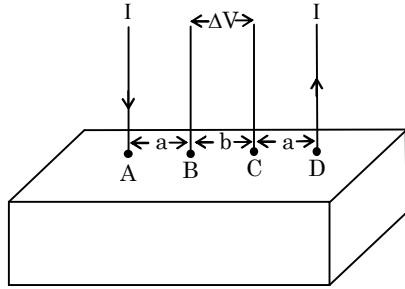

Q.13 For current entering at A, the electric field at a distance ' r ' from A is -

- (A) $\frac{\rho I}{r^2}$ (B) $\frac{\rho I}{2\pi r^2}$ (C) $\frac{\rho I}{4\pi r^2}$ (D) $\frac{\rho I}{8\pi r^2}$

Q.14 ΔV measured between B and C is -

- (A) $\frac{\rho I}{a} - \frac{\rho I}{(a+b)}$ (B) $\frac{\rho I}{2\pi a} - \frac{\rho I}{2\pi(a+b)}$
 (C) $\frac{\rho I}{2\pi(a-b)}$ (D) $\frac{\rho I}{\pi a} - \frac{\rho I}{\pi(a+b)}$

Q.15 Shown in the figure below is a meter-bridge set up with null deflection in the galvanometer.

[AIEEE-2008]

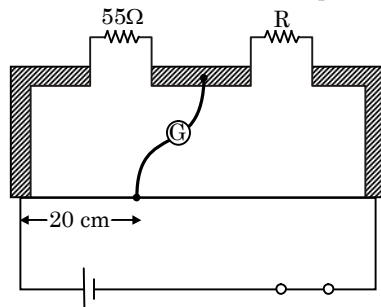

The value of the unknown resistor R is -

- (A) 220Ω (B) 110Ω
 (C) 55Ω (D) 13.75Ω

Q.16 **Statement-1:** The temperature dependence of resistance is usually given as $R = R_0(1 + \alpha \Delta t)$. The resistance of a wire changes from 100Ω to 150Ω when its temperature is increased from 27°C to 227°C . This implies that $\alpha = 2.5 \times 10^{-3}/^\circ\text{C}$.

Statement-2 : $R = R_0(1 + \alpha \Delta t)$ is valid only when the change in the temperature ΔT is small and $\Delta R = (R - R_0) \ll R_0$. [AIEEE-2009]

- (A) Statement-1 is true, Statement-2 is true; Statement-2 is a correct explanation for Statement-1
 (B) Statement-1 is true. Statement-2 is true; Statement-2 is not a correct explanation for Statement-1
 (C) Statement-1 is true, Statement-2 is false.
 (D) Statement-1 is false, Statement-2 is true.

Q.17 A resistance R and a capacitance C are connected in series to a battery of negligible internal resistance through a key. The key is closed at $t = 0$. If after t sec the voltage across the capacitance was seven times the voltage across R , the value of t is :

[JEE Main Online -2012]

- (A) $3 RC \ln 7$ (B) $3 RC \ln 2$
 (C) $2 RC \ln 2$ (D) $2 RC \ln 7$

Q.18 Three resistance of 4Ω , 6Ω and 12Ω are connected in parallel and the combination is connected in series with a 1.5 V battery of 1Ω internal resistance. The rate of Joule heating in the 4Ω resistor is :

[JEE Main Online -2012]

- (A) 0.86 W (B) 0.25 W (C) 0.33 W (D) 0.55 W

Q.19 Two electric bulbs marked $25 \text{ W} - 220 \text{ V}$ and $100 \text{ W} - 220 \text{ V}$ are connected in series to a 440 V supply. Which of the bulbs will fuse ?

[AIEEE-2012]

- (A) 100 W (B) 25 W
 (C) neither (D) both

Q.20 The supply voltage to a room is 120 V . The resistance of the lead wires is 6Ω . A 60 W bulb is already switched on. What is the decrease of voltage across the bulb, when a 240 W heater is switched on in parallel to the bulb ?

[JEE-Main 2013]

- (A) 13.3 V (B) 10.04 V
 (C) zero V (D) 2.9 V

Q.21 **Statement-I :** Higher the range, greater is the resistance of ammeter.

Statement-II : To increase the range of ammeter, additional shunt needs to be used across it. [JEE-Main 2013]

- (A) If statement-I is true but statement-II is false.
 (B) If statement-I is false but statement-II is true.
 (C) If both statement-I and statement-II are true, and statement-II is the **correct** explanation of statement-I.
 (D) If both statement-I and statement-II are true but statement-II is **not** the correct explanation of statement-I

Q.22 In a metre bridge experiment null point is obtained at 40 cm from one end of the wire when resistance X is balanced against another resistance Y . If $X < Y$, then the new position of the null point from the same end, if one decide to balance a resistance of $3X$ against Y , will be close to :

[JEE Main Online -2013]

- (A) 80 cm (B) 75 cm (C) 67 cm (D) 50 cm

- Q.23** To find the resistance of a galvanometer by the half deflection method the following circuit is used with resistances $R_1 = 9970 \Omega$, $R_2 = 30 \Omega$ and $R_3 = 0$. The deflection in the galvanometer is d . With $R_3 = 107 \Omega$ the deflection change to $d/2$. The galvanometer resistance is approximately-

[JEE Main Online-2013]

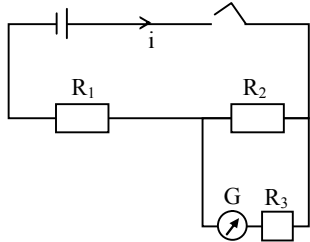

- (A) 107Ω (B) 137Ω
(C) $107/2 \Omega$ (D) 77Ω

- Q.24** A dc source of emf $E_1 = 100 \text{ V}$ and internal resistance $r = 0.5 \Omega$, a storage battery of emf $E_2 = 90 \text{ V}$ and an external resistance R are connected as shown in figure. For what value of R no current will pass through battery -

[JEE Main Online -2013]

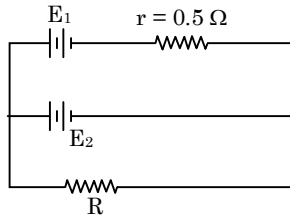

- (A) 5.5Ω (B) 3.5Ω (C) 4.5Ω (D) 2.5Ω

- Q.25** Which of the four resistances P , Q , R and S generate the greatest amount of heat when a current flows from A to B ?

[JEE Main Online -2013]

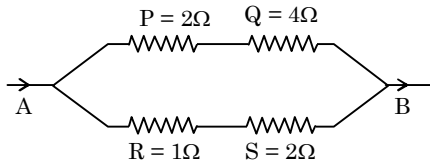

- (A) Q (B) S (C) P (D) R

- Q.26** Six equal resistance are connected between points P , Q and R as shown in figure. Then net resistance will be maximum between -

[JEE Main Online-2013]

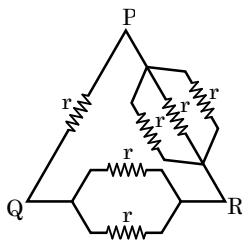

- (A) P and R (B) P and Q
(C) Q and R (D) Any two points

- Q.27** A d.c. main supply of e.m.f 220 V is connected across a storage battery of e.m.f. 200 V through a resistance of 1Ω . The battery terminals are connected to an external resistance ' R '. The minimum value of ' R ', so that a current passes through the battery to charge it is :

[JEE Main Online-2014]

- (A) 7Ω (B) 9Ω (C) 11Ω (D) Zero

- Q.28** The circuit shown here has two batteries of 8.0 V and 16.0 V and three resistors 3Ω , 9Ω and 9Ω and a capacitor $5.0 \mu\text{F}$.

[JEE Main Online-2014]

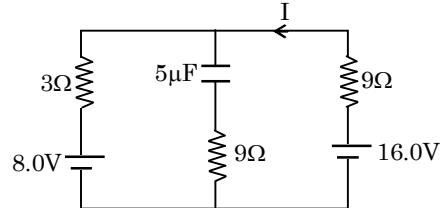

How much is the current I in the circuit in steady state?

- (A) 1.6 A (B) 0.67 A (C) 2.5 A (D) 0.25 A

- Q.29** Four bulbs B_1 , B_2 , B_3 and B_4 of 100 W each are connected to 220V main as shown in the figure. The reading in an ideal ammeter will be :

[JEE Main Online-2014]

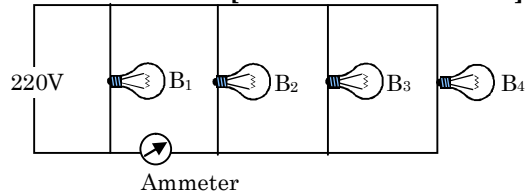

- (A) 0.45 A (B) 0.90 A (C) 1.35 A (D) 1.80 A

- Q.30** In a large building, there are 15 bulbs of 40 W , 5 bulbs of 100 W , 5 fans of 80 W and 1 heater of 1 kW . The voltage of the electric mains is 220 V . The minimum capacity of the main fuse of the building will be - [JEE-Main 2014]

- (A) 10 A (B) 12 A (C) 14 A (D) 8 A

- Q.31** When 5 V potential difference is applied across a wire of length 0.1 m , the drift speed of electrons is $2.5 \times 10^{-4} \text{ ms}^{-1}$. If the electron density in the wire is $8 \times 10^{28} \text{ m}^{-3}$, the resistivity of the material is close to -

[JEE Main -2015]

- (A) $1.6 \times 10^{-8} \Omega\text{m}$ (B) $1.6 \times 10^{-7} \Omega\text{m}$
(C) $1.6 \times 10^{-6} \Omega\text{m}$ (D) $1.6 \times 10^{-5} \Omega\text{m}$

- Q.32** In the circuit shown, the current in the 1Ω resistor is - [JEE Main -2015]

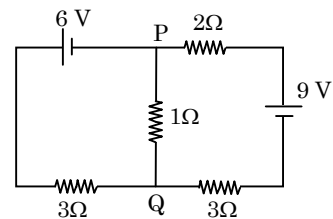

- (A) 1.3 A , from P to Q (B) 0 A
(C) 0.13 A , from Q to P (D) 0.13 A , from P to Q

- Q.33** In the electric network shown, when no current flows through the 4Ω resistor in the arm EB, the potential difference between the points A and D will be : **[JEE Main Online-2015]**

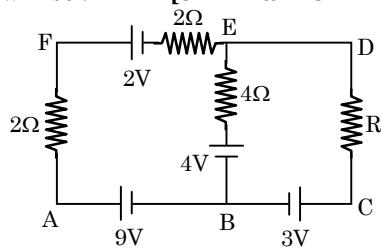

- (A) 3 V (B) 5 V (C) 4 V (D) 6 V

- Q.34** A combination of capacitors is set up as shown in the figure. The magnitude of the electric field, due to a point charge Q (having a charge equal to the sum of the charges on the $4\mu\text{F}$ and $9\mu\text{F}$ capacitors), at a point distant 30 m from it, would equal **[JEE Main-2016]**

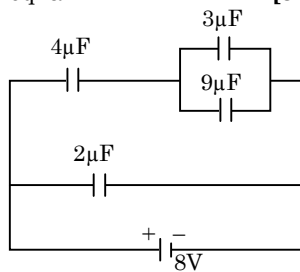

- (A) 240 N/C (B) 360 N/C
(C) 420 N/C (D) 480 N/C

- Q.35** In the circuit shown, the resistance r is a variable resistance. If for $r = f R$, the heat generation in r is maximum then the value of f is : **[JEE Main Online-2016]**

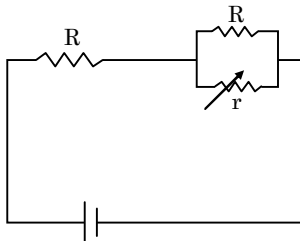

- (A) $\frac{1}{4}$ (B) $\frac{1}{2}$ (C) $\frac{3}{4}$ (D) 1

- Q.36** In the given circuit diagram when the current reaches steady state in the circuit, the charge on the capacitor of capacitance C will be : **[JEE Main -2017]**

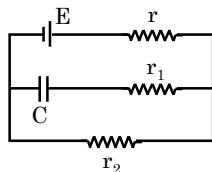

- (A) CE (B) $CE \frac{r_1}{(r_2 + r)}$
(C) $CE \frac{r_2}{(r + r_2)}$ (D) $CE \frac{r_1}{(r_1 + r)}$

- Q.37** In the given circuit the current in each resistance is : **[JEE Main -2017]**

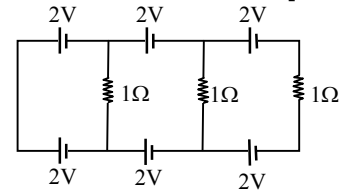

- (A) 1 A (B) 0.25 A (C) 0.5 A (D) 0 A

- Q.38** A potentiometer PQ is set up to compare two resistances as shown in the figure. The ammeter A in the circuit reads 1.0 A when two way key K_3 is open. The balance point is at a length ℓ_1 cm from P when two way key K_3 is plugged in between 2 and 1, while the balance point is at a length ℓ_2 cm from P when key K_3 is plugged in between 3 and 1. The

ratio of the two resistance $\frac{R_1}{R_2}$, is found to be -

[JEE Main Online-2017]

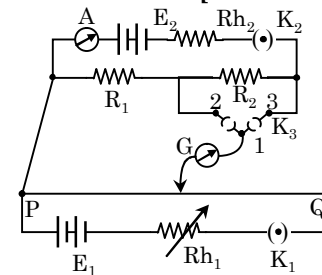

- (A) $\frac{\ell_1}{\ell_1 - \ell_2}$ (B) $\frac{\ell_2}{\ell_2 - \ell_1}$
(C) $\frac{\ell_1}{\ell_1 + \ell_2}$ (D) $\frac{\ell_1}{\ell_2 - \ell_1}$

- Q.39** In a meter bridge experiment resistances are connected as shown in the figure. Initially resistance $P = 4\Omega$ and the neutral point N is at 60 cm from A. Now an unknown resistance R is connected in series to P and the new position of the neutral point is at 80 cm from A. The value of unknown resistance R is -

[JEE Main Online-2017]

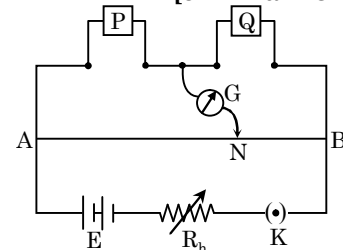

- (A) $\frac{33}{5}\Omega$ (B) 6Ω (C) $\frac{20}{3}\Omega$ (D) 7Ω

- Q.40** The figure shows three circuits I, II and III which are connected to a 3V battery. If the powers dissipated by the configuration I, II and III are P_1 , P_2 and P_3 respectively, then -

[JEE Main Online-2017]

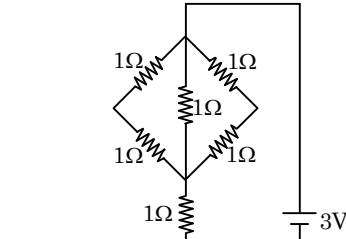
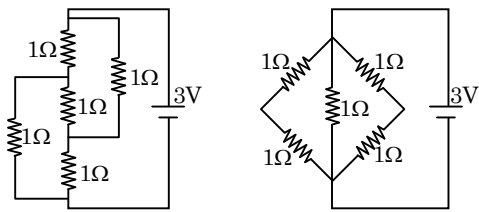

- (A) $P_2 > P_1 > P_3$ (B) $P_1 > P_2 > P_3$
 (C) $P_3 > P_2 > P_1$ (D) $P_1 > P_3 > P_2$

- Q.41** Two batteries with e.m.f. 12 V and 13 V are connected in parallel across a load resistor of 10 Ω. The internal resistances of the two batteries are 1 Ω and 2 Ω respectively. The voltage across the load lies between : **[JEE Main - 2018]**
 (A) 11.6 V and 11.7 V (B) 11.5 V and 11.6 V
 (C) 11.4 V and 11.5 V (D) 11.7 V and 11.8 V

- Q.42** In a potentiometer experiment, it is found that no current passes through the galvanometer when the terminals of the cell are connected across 52 cm of the potentiometer wire. If the cell is shunted by a resistance of 5 Ω, a balance is found when the cell is connected across 40 cm of the wire. Find the internal resistance of the cell. **[JEE Main - 2018]**
 (A) 1 Ω (B) 1.5 Ω (C) 2 Ω (D) 2.5 Ω

- Q.43** On interchanging the resistances, the balance point of a meter bridge shifts to the left by 10 cm. The resistance of their series combination is 1 kΩ. How much was the resistance on the left slot before inter-changing the resistances ? **[JEE Main - 2018]**
 (A) 990 Ω (B) 505 Ω (C) 550 Ω (D) 910 Ω

- Q.44** In the given circuit all resistances are of value R ohm each. The equivalent resistance between A and B is: **[JEE-Main Online-2018]**

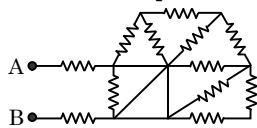

- (A) 2 R (B) $\frac{5R}{2}$ (C) $\frac{5R}{3}$ (D) 3 R

- Q.45** In a meter bridge, as shown in the figure, it is given that resistance $Y = 12.5 \Omega$ and that the balance is obtained at a distance 39.5 cm from end A (by jockey J). After interchanging the resistances X and Y, a new balance point is found at a distance ℓ_2 from end A. What are the values of X and ℓ_2 ? **[JEE-Main Online-2018]**

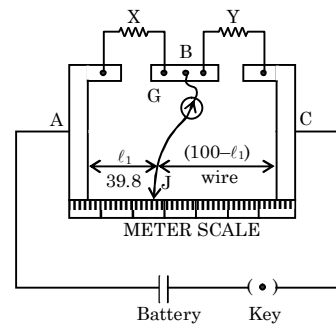

- (A) 19.15 Ω and 39.5 cm (B) 8.16 Ω and 60.5 cm
 (C) 19.15 Ω and 60.5 cm (D) 5.16 Ω and 39.5 cm

- Q.46** A constant voltage is applied between two ends of metallic wire. If the length is halved and the radius of the wire is doubled, the rate of heat developed in the wire will be – **[JEE-Main Online-2018]**
 (A) Increased 8 times (B) Doubled
 (C) Halved (D) Unchanged

- Q.47** A copper rod of cross-sectional area A carries a uniform current I through it. At temperature T, if the volume charge density of the rod is ρ , how long will the charges take to travel a distance d ? **[JEE-Main Online-2018]**

- (A) $\frac{2\rho dA}{IT}$ (B) $\frac{2\rho dA}{I}$ (C) $\frac{\rho dA}{I}$ (D) $\frac{\rho dA}{IT}$

- Q.48** A heating element has a resistance of 100 Ω at room temperature. When it is connected to a supply of 220 V, a steady current of 2 A passes in it and temperature is 500°C more than room temperature. What is the temperature coefficient of resistance of the heating element ? **[JEE-Main Online-2018]**
 (A) $1 \times 10^{-4} \text{ }^\circ\text{C}^{-1}$ (B) $5 \times 10^{-4} \text{ }^\circ\text{C}^{-1}$
 (C) $2 \times 10^{-4} \text{ }^\circ\text{C}^{-1}$ (D) $0.5 \times 10^{-4} \text{ }^\circ\text{C}^{-1}$

- Q.49** In a circuit for finding the resistance of a galvanometer by half deflection method, a 6 V battery and high resistance of 11 kΩ are used. The figure of merit of the galvanometer 60 μA/division. In the absence of shunt resistance, the galvanometer produces a deflection of $\theta = 9$ divisions when current flows in the circuit. The value of the shunt resistance that can cause the deflection of $\theta/2$, is closed to - **[JEE-Main Online-2018]**
 (A) 55 Ω (B) 110 Ω (C) 220 Ω (D) 550 Ω

- Q.50** In the following circuit, the switch S is closed at $t = 0$. The charge on the capacitor C_1 as a function of time will be given by **[JEE-Main Online-2018]**

$$\left(C_{eq} = \frac{C_1 C_2}{C_1 + C_2} \right)$$

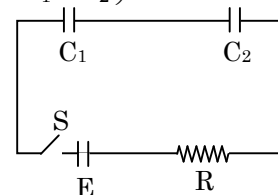

- (A) $C_{eq}E[1 - \exp(-t/RC_{eq})]$ (B) $C_1E[1 - \exp(-t/RC_1)]$
 (C) $C_2E[1 - \exp(-t/RC_2)]$ (D) $C_{eq}E \exp(-t/RC_{eq})$

- Q.51** A galvanometer with its coil resistance 25Ω requires at current of 1mA for its full deflection. In order to construct an ammeter to read up to a current of 2A , the approximate value of the shunt resistance should be- **[JEE-Main Online-2018]**
 (A) $2.5 \times 10^{-2}\Omega$ (B) $1.25 \times 10^{-3}\Omega$
 (C) $2.5 \times 10^{-3}\Omega$ (D) $1.25 \times 10^{-2}\Omega$

- Q.52** Drift speed of electrons, when 1.5A of current flows in a copper wire of cross section 5mm^2 , is v . If electron density in copper is $9 \times 10^{28}/\text{m}^3$ the value of v in mm/s is close to - (Take charge of electron to be $= 1.6 \times 10^{-19}\text{C}$) **[Main-2019]**
 (A) 0.02 (B) 0.2 (C) 3 (D) 2

- Q.53** When the switch S , in circuit shown, is closed, then the value of current i will be : **[Main-2019]**

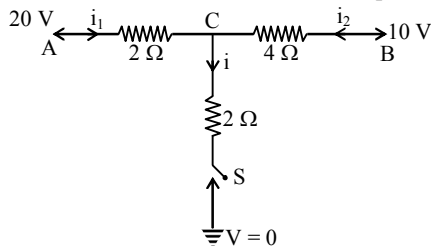

- (A) 4 A (B) 5 A (C) 3 A (D) 2 A

- Q.54** A copper wire is stretched to make it 0.5% longer. The percentage change in its electrical resistance if its volume remains unchanged is : **[Main-2019]**
 (A) 0.5 % (B) 2.5 % (C) 2.0 % (D) 1.0 %

- Q.55** A moving coil galvanometer, having a resistance G , produces full scale deflection when a current I_g flows through it. This galvanometer can be converted into (i) an ammeter of range 0 to $I_0(I_0 > I_g)$ by connecting a shunt resistance R_A to it and (ii) into a voltmeter of range 0 to V ($V = GI_0$) by connecting a series resistance R_V to it. Then, **[Main-2019]**

- (A) $R_A R_V = G^2$ & $\frac{R_A}{R_V} = \frac{I_g}{(I_0 - I_g)}$
 (B) $R_A R_V = G^2 \left(\frac{I_g}{I_0 - I_g} \right)$ & $\frac{R_A}{R_V} = \left(\frac{I_0 - I_g}{I_g} \right)^2$
 (C) $R_A R_V = G^2 \left(\frac{I_0 - I_g}{I_g} \right)$ & $\frac{R_A}{R_V} = \left(\frac{I_g}{(I_0 - I_g)} \right)^2$
 (D) $R_A R_V = G^2$ & $\frac{R_A}{R_V} = \left(\frac{I_g}{I_0 - I_g} \right)^2$

- Q.56** A carbon resistance has a following colour code. What is the value of the resistance? **[Main-2019]**

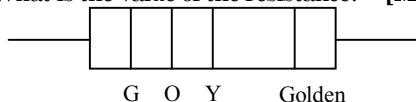

- (A) $5.3\text{M}\Omega \pm 5\%$ (B) $530\text{k}\Omega \pm 5\%$
 (C) $64\text{k}\Omega \pm 10\%$ (D) $6.4\text{M}\Omega \pm 5\%$

- Q.57** In the given circuit the internal resistance of the 18V cell is negligible. If $R_1 = 400\Omega$, $R_3 = 100\Omega$ and $R_4 = 500\Omega$ and the reading of an ideal voltmeter across R_4 is 5V , then the value of R_2 will be : **[Main-2019]**

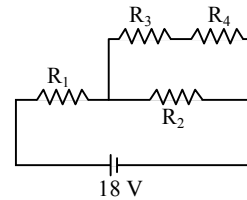

- (A) 550Ω (B) 450Ω (C) 230Ω (D) 300Ω

- Q.58** A uniform metallic wire has a resistance of 18Ω and is bent into an equilateral triangle. Then, the resistance between any two vertices of the triangle is - **[Main-2019]**
 (A) 12Ω (B) 2Ω (C) 4Ω (D) 8Ω

- Q.59** A 2W carbon resistor is color coded with green, black, red and brown respectively. The maximum current which can be passed through this resistor is - **[Main-2019]**
 (A) 0.4mA (B) 20mA (C) 63mA (D) 100mA

- Q.60** In the given circuit the cells have zero internal resistance. The currents (in Amperes) passing through resistance R_1 and R_2 respectively, are - **[Main-2019]**

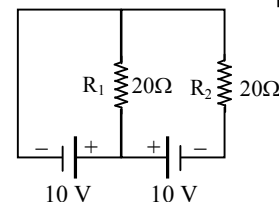

- (A) 0.5, 0 (B) 0, 1 (C) 1, 2 (D) 2, 2

- Q.61** A potentiometer wire AB having length L and resistance $12r$ is joined to a cell D of emf ϵ and internal resistance r . A cell C having emf $\epsilon/2$ and internal resistance $3r$ is connected. The length AJ at which the galvanometer as shown in figure shows no deflection is - **[Main-2019]**

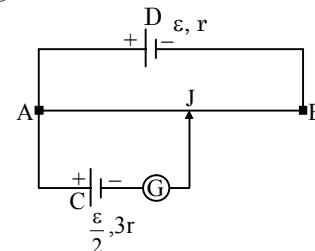

- (A) $\frac{11}{12}L$ (B) $\frac{13}{24}L$
 (C) $\frac{5}{12}L$ (D) $\frac{11}{24}L$

- Q.62** A current of 2 mA was passed through an unknown resistor which dissipated a power of 4.4 W. Dissipated power when an ideal power supply of 11 V is connected across it is - **[Main-2019]**
 (A) 11×10^{-5} W (B) 11×10^{-3} W
 (C) 11×10^5 W (D) 11×10^{-4} W

- Q.63** The Wheatstone bridge shown in figure, here, gets balanced when the carbon resistor used as R_1 has the colour code (Orange, Red, Brown). The resistors R_2 and R_4 are 80Ω and 40Ω , respectively. Assuming that the colour code for the carbon resistors gives their accurate values, the colour code for the carbon resistor, used as R_3 , would be - **[Main-2019]**

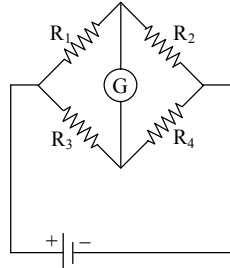

- (A) Brown, Blue, Brown (B) Grey, Black, Brown
 (C) Red, Green, Brown (D) Brown, Blue, Black

- Q.64** The actual value of resistance R , shown in the figure is 30Ω . This is measured in an experiment as shown using the standard formula $R = \frac{V}{I}$, where V and I are the readings of the voltmeter and ammeter, respectively. If the measured value of R is 5% less, then the internal resistance of the voltmeter is - **[Main-2019]**

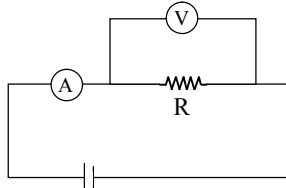

- (A) 570Ω (B) 600Ω (C) 350Ω (D) 35Ω

- Q.65** Two equal resistances when connected in series to a battery, consume electric power of 60 W. If these resistances are now connected in parallel combination to the same battery, the electric power consumed will be : **[Main-2019]**
 (A) 240 W (B) 60 W (C) 30 W (D) 120 W

- Q.66** The resistance of the meter bridge AB in given figure is 4Ω . With a cell of emf $\varepsilon = 0.5$ V and rheostat resistance $R_h = 2\Omega$ the null point is obtained at some point J. When the cell is replaced by another one of emf $\varepsilon = \varepsilon_2$ the same null point J is found for $R_h = 6\Omega$. The emf ε_2 is : **[Main-2019]**

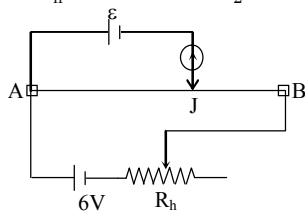

- (A) 0.3 V (B) 0.6 V (C) 0.5 V (D) 0.4 V

- Q.67** In a Wheatstone bridge(see fig.), Resistances P and Q are approximately equal. When $R = 400\Omega$, the bridge is balanced. On interchanging P and Q, the value of R, for balance, is 405Ω . The value of X is close to: **[Main-2019]**

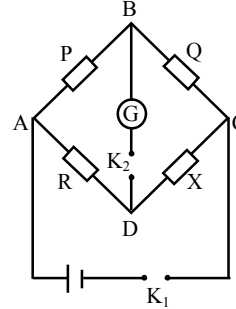

- (A) 402.5 ohm (B) 401.5 ohm
 (C) 403.5 ohm (D) 404.5 ohm

- Q.68** In the circuit shown, the potential difference between A and B is : **[Main-2019]**

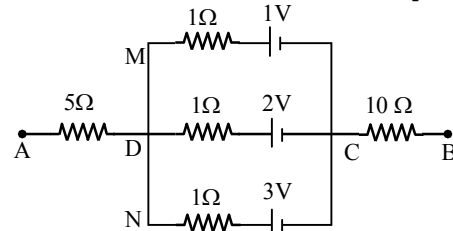

- (A) 6 V (B) 3 V (C) 2 V (D) 1 V

- Q.69** In the experimental set up of metre bridge shown in the figure, the null point is obtained at a distance of 40 cm from A. If a 10Ω resistor is connected in series with R_1 , the null point shifts by 10 cm. The resistance that should be connected in parallel with $(R_1 + 10)\Omega$ such that the null point shifts back to its initial position is : **[Main-2019]**

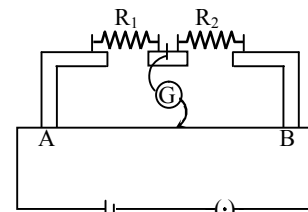

- (A) 40Ω (B) 30Ω (C) 20Ω (D) 60Ω

- Q.70** A galvanometer having a resistance of 20Ω and 30 divisions on both sides has figure of merit 0.005 ampere/division. The resistance that should be connected in series such that it can be used as a voltmeter upto 15 volt, is : **[Main-2019]**
 (A) 120Ω (B) 125Ω (C) 80Ω (D) 100Ω

- Q.71** The galvanometer deflection, when key K_1 is closed but K_2 is open, equals θ_0 (see figure). On closing K_2 also and adjusting R_2 to 5Ω , the deflection in galvanometer becomes $\frac{\theta_0}{5}$. The resistance of the galvanometer is, then, given by [Neglect the internal resistance of battery] : **[Main-2019]**

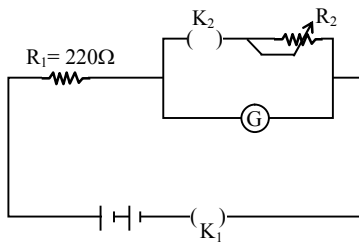

- (A) $5\ \Omega$ (B) $25\ \Omega$ (C) $12\ \Omega$ (D) $22\ \Omega$

Q.72 An ideal battery of 4 V and resistance R are connected in series in the primary circuit of a potentiometer of length 1 m and resistance $5\ \Omega$. The value of R , to give a potential difference of 5 mV across 10 cm of potentiometer wire, is :

[Main-2019]

- (A) $480\ \Omega$ (B) $495\ \Omega$ (C) $490\ \Omega$ (D) $395\ \Omega$

Q.73 In a meter bridge, the wire of length 1 m has a non-uniform cross-section such that, the variation $\frac{dR}{d\ell}$ of its resistance R with length ℓ is

$\frac{dR}{d\ell} \propto \frac{1}{\sqrt{\ell}}$. Two equal resistances are connected

as shown in the figure. The galvanometer has zero deflection when the jockey is at point P . What is the length AP ? [Main-2019]

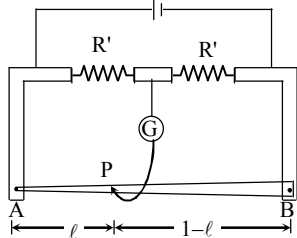

- (A) 0.3 m (B) 0.25 m (C) 0.35 m (D) 0.2 m

Q.74 Two electric bulbs, rated at $(25\text{ W}, 220\text{ V})$ and $(100\text{ W}, 220\text{ V})$, are connected in series across a 220 V voltage source. If the 25 W and 100 W bulbs draw powers P_1 and P_2 respectively, then :

[Main-2019]

- (A) $P_1 = 4\text{ W}, P_2 = 16\text{ W}$ (B) $P_1 = 16\text{ W}, P_2 = 4\text{ W}$
(C) $P_1 = 9\text{ W}, P_2 = 16\text{ W}$ (D) $P_1 = 16\text{ W}, P_2 = 9\text{ W}$

Q.75 A galvanometer, whose resistance is 50 ohm , has 25 divisions in it. When a current of $4 \times 10^{-4}\text{ A}$ passes through it, its needle (pointer) deflects by one division. To use this galvanometer as a voltmeter of range 2.5 V , it should be connected to a resistance of :

[Main-2019]

- (A) 200 ohm (B) 250 ohm (C) 6200 ohm (D) 6250 ohm

Q.76 In the given circuit diagram, the currents, $I_1 = -0.3\text{ A}$, $I_4 = 0.8\text{ A}$ and $I_5 = 0.4\text{ A}$, are flowing as shown. The currents I_2, I_3 and I_6 , respectively, are :

[Main-2019]

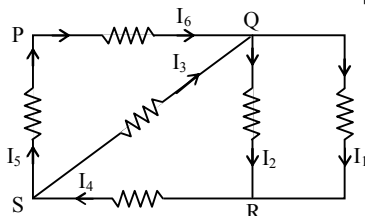

- (A) $1.1\text{ A}, -0.4\text{ A}, 0.4\text{ A}$ (B) $-0.4\text{ A}, 0.4\text{ A}, 1.1\text{ A}$
(C) $0.4\text{ A}, 1.1\text{ A}, 0.4\text{ A}$ (D) $1.1\text{ A}, 0.4\text{ A}, 0.4\text{ A}$

Q.77 For the circuit shown, with $R_1 = 1.0\ \Omega$, $R_2 = 2.0\ \Omega$, $E_1 = 2\text{ V}$ and $E_2 = E_3 = 4\text{ V}$, the potential difference between the points 'a' and 'b' is approximately (in V) - [Main-2019]

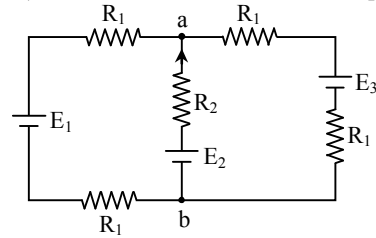

- (A) 3.7 (B) 2.7 (C) 2.3 (D) 3.3

Q.78 A $200\ \Omega$ resistor has a certain color code. If one replaces the red color by green in the code, the new resistance will be - [Main-2019]

- (A) $100\ \Omega$ (B) $500\ \Omega$ (C) $400\ \Omega$ (D) $300\ \Omega$

Q.79 A cell of internal resistance r drives current through an external resistance R . The power delivered by the cell to the external resistance will be maximum when- [Main-2019]

- (A) $R = 1000r$ (B) $R = 0.001r$
(C) $R = 2r$ (D) $R = r$

Q.80 In the circuit shown, a four-wire potentiometer is made of a 400 cm long wire, which extends between A and B. The resistance per unit length of the potentiometer wire is $r = 0.01\ \Omega/\text{cm}$. If an ideal voltmeter is connected as shown with jockey J at 50 cm from end A, the expected reading of the voltmeter will be -

[Main-2019]

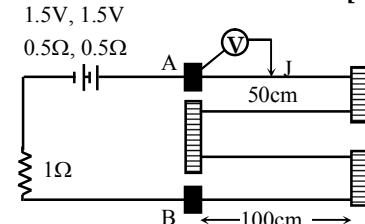

- (A) 0.75 V (B) 0.25 V (C) 0.50 V (D) 0.20 V

Q.81 In the figure shown, what is the current (in Ampere) drawn from the battery? You are given - $R_1 = 15\ \Omega$, $R_2 = 10\ \Omega$, $R_3 = 20\ \Omega$, $R_4 = 5\ \Omega$, $R_5 = 25\ \Omega$, $R_6 = 30\ \Omega$, $E = 15\text{ V}$ [Main-2019]

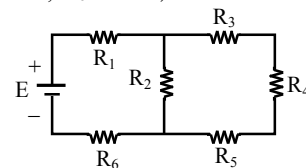

- (A) $7/18$ (B) $20/3$ (C) $9/32$ (D) $13/24$

Q.82 A moving coil galvanometer has resistance $50\ \Omega$ and it indicates full deflection at 4 mA current. A voltmeter is made using this galvanometer and a $5\text{ k}\Omega$ resistance. The maximum voltage, that can be measured using this voltmeter, will be close to : [Main-2019]

- (A) 40 V (B) 10 V (C) 15 V (D) 20 V

- Q.83** Determine the charge on the capacitor in the following circuit : **[Main-2019]**

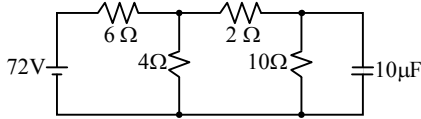

- (A) $200 \mu\text{C}$ (B) $10 \mu\text{C}$ (C) $60 \mu\text{C}$ (D) $2 \mu\text{C}$

- Q.84** A wire of resistance R is bent to form a square ABCD as shown in the figure. The effective resistance between E and C is : (E is mid-point of arm CD) **[Main-2019]**

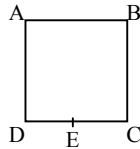

- (A) $\frac{3}{4}R$ (B) $\frac{1}{16}R$ (C) $\frac{7}{64}R$ (D) R

- Q.85** One kg of water, at 20°C , heated in an electric kettle whose heating element has a mean (temperature averaged) resistance of 20Ω . The rms voltage in the mains is 200 V . Ignoring heat loss from the kettle, time taken for water to evaporate fully, is close to :
[Specific heat of water = $4200 \text{ J}/(\text{kg } ^\circ\text{C})$, Latent heat of water = $2260 \text{ kJ}/\text{kg}$] **[Main-2019]**
- (A) 10 minutes (B) 22 minutes
(C) 3 minutes (D) 16 minutes

- Q.86** The resistance of a galvanometer is 50 ohm and the maximum current which can be passed though it is 0.002 A . What resistance must be connected to it in order to convert it into an ammeter of range $0-0.5 \text{ A}$? **[Main-2019]**
- (A) 0.2 ohm (B) 0.002 ohm
(C) 0.02 ohm (D) 0.5 ohm

- Q.87** In a conductor, if the number of conduction electrons per unit volume is $8.5 \times 10^{28} \text{ m}^{-3}$ and mean free time is 25 fs (femto second), its approximate resistivity is :
($m_e = 9.1 \times 10^{-31} \text{ kg}$) **[Main-2019]**
- (A) $10^{-5} \Omega\text{m}$ (B) $10^{-7} \Omega\text{m}$
(C) $10^{-8} \Omega\text{m}$ (D) $10^{-6} \Omega\text{m}$

- Q.88** A metal wire of resistance 3Ω is elongated to make a uniform wire of double its previous length. This new wire is now bent and the ends joined to make a circle. If two points on this circle make an angle 60° at the centre, the equivalent resistance between these two points will be : **[Main-2019]**
- (A) $\frac{5}{2} \Omega$ (B) $\frac{5}{3} \Omega$ (C) $\frac{7}{2} \Omega$ (D) $\frac{12}{5} \Omega$

- Q.89** A moving coil galvanometer allows a full scale current of 10^{-4} A . A series resistance of $2 \text{ M}\Omega$ is required to convert the above galvanometer into a voltmeter of range $0-5 \text{ V}$. Therefore the value of

shunt resistance required to convert the above galvanometer into an ammeter of range $0-10 \text{ mA}$ is : **[Main-2019]**

- (A) 10Ω (B) 500Ω (C) 100Ω (D) 200Ω

- Q.90** A current of 5 A passes through a copper conductor (resistivity = $1.7 \times 10^{-8} \Omega\text{m}$) of radius of cross-section 5 mm . Find the mobility of the charges if their drift velocity is $1.1 \times 10^{-3} \text{ m/s}$. **[Main-2019]**

- (A) $1.0 \text{ m}^2/\text{Vs}$ (B) $1.8 \text{ m}^2/\text{Vs}$
(C) $1.5 \text{ m}^2/\text{Vs}$ (D) $1.3 \text{ m}^2/\text{Vs}$

- Q.91** In the given circuit, an ideal voltmeter connected across the 10Ω resistance reads 2V . The internal resistance r , of each cell is: **[Main-2019]**

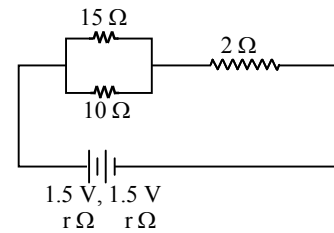

- (A) 1Ω (B) 0.5Ω (C) 1.5Ω (D) 0Ω

- Q.92** In a meter bridge experiment, the circuit diagram and the corresponding observation table are shown in figure. **[Main-2019]**

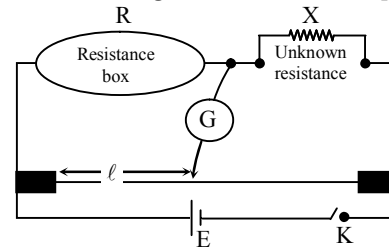

Sl. No.	$R (\Omega)$	$l (\text{cm})$
1.	1000	60
2.	100	13
3.	10	1.5
4.	1	1.0

Which of the reading is inconsistent ?

- (A) 3 (B) 4 (C) 2 (D) 1

- Q.93** In an experiment, the resistance of a material is plotted as a function of temperature (in some range). As shown in the figure, it is a straight line. **[Main-2019]**

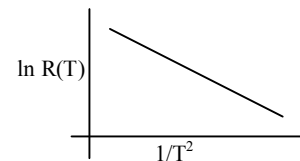

One may conclude that :

- (A) $R(T) = R_0 e^{T^2/T_0^2}$ (B) $R(T) = \frac{R_0}{T^2}$
(C) $R(T) = R_0 e^{-T^2/T_0^2}$ (D) $R(T) = R_0 e^{-T_0^2/T^2}$

Q.94 Space between two concentric conducting spheres of radii a and b ($b > a$) is filled with a medium of resistivity ρ . The resistance between the two spheres will be - **[Main-2019]**

- (A) $\frac{\rho}{2\pi} \left(\frac{1}{a} + \frac{1}{b} \right)$ (B) $\frac{\rho}{4\pi} \left(\frac{1}{a} + \frac{1}{b} \right)$
 (C) $\frac{\rho}{2\pi} \left(\frac{1}{a} - \frac{1}{b} \right)$ (D) $\frac{\rho}{4\pi} \left(\frac{1}{a} - \frac{1}{b} \right)$

Q.95 The resistive network shown below is connected to a D.C. source of 16 V. The power consumed by the network is 4 Watt. The value of R is : **[Main-2019]**

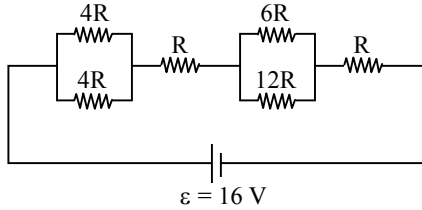

- (A) 16Ω (B) 1Ω (C) 8Ω (D) 6Ω

Q.96 Consider four conducting materials copper, tungsten, mercury and aluminium with resistivity $\rho_C > \rho_T > \rho_M$ and ρ_A respectively. Then: **[JEE Main 2020]**

- (A) $\rho_A > \rho_T > \rho_C$ (B) $\rho_C > \rho_A > \rho_T$
 (C) $\rho_A > \rho_M > \rho_C$ (D) $\rho_M > \rho_A > \rho_C$

Q.97 Model a torch battery of length ℓ to be made up of a thin cylindrical bar of radius 'a' and a concentric thin cylindrical shell of radius 'b' filled in between with an electrolyte of resistivity ρ (see figure). If the battery is connected to a resistance of value R , the maximum Joule heating in R will take place for **[JEE Main 2020]**

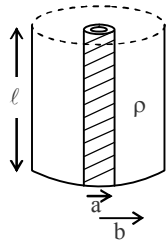

- (A) $R = \frac{2\rho}{\pi\ell} \ln\left(\frac{b}{a}\right)$ (B) $R = \frac{\rho}{\pi\ell} \ln\left(\frac{b}{a}\right)$
 (C) $R = \frac{\rho}{2\pi\ell} \left(\frac{b}{a}\right)$ (D) $R = \frac{\rho}{2\pi\ell} \ln\left(\frac{b}{a}\right)$

Q.98 A potentiometer wire PQ of 1 m length is connected to a standard cell E_1 . Another cell E_2 of emf 1.02 V is connected with a resistance 'r' and switch S (as shown in figure). With switch S open, the null position is obtained at a distance of 49 cm from Q. The potential gradient in the potentiometer wire is : **[JEE Main 2020]**

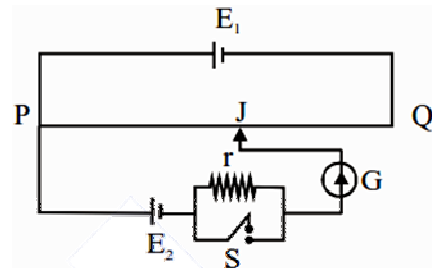

- (A) 0.02 V/cm (B) 0.04 V/cm
 (C) 0.01 V/cm (D) 0.03 V/cm

Q.99 Two resistors 400Ω and 800Ω are connected in series across a 6 V battery. The potential difference measured by a voltmeter of $10 \text{ k}\Omega$ across 400Ω resistor is close to : **[JEE Main 2020]**

- (A) 2.05 V (B) 1.95 V (C) 2 V (D) 1.8 V

Q.100 A current through a wire depends on time $= \alpha_0 t + \beta t^2$ where $\alpha = 20 \text{ A/s}$ and $\beta = 8 \text{ As}^{-2}$. Find the charge crossed through a section of the wire in 15 s. **[JEE MAIN 2021]**

- (A) 2250 C (B) 11250 C
 (C) 2100 C (D) 260 C

Q.101 A wire of 1Ω has a length of 1m. It is stretched till its length increases by 25%. The percentage change in resistance to the nearest integer is : **[JEE MAIN 2021]**

- (A) 56% (B) 25% (C) 12.5% (D) 76%

Q.102 A conducting wire of length ' l ', area of cross-section A and electric resistivity ρ is connected between the terminals of a battery. A potential difference V is developed between its ends, causing an electric current. If the length of the wire of the same material is doubled and the area of cross-section is halved, the resultant current would be : **[JEE MAIN 2021]**

- (A) $\frac{1}{4} \frac{VA}{\rho l}$ (B) $\frac{3}{4} \frac{VA}{\rho l}$
 (C) $\frac{1}{4} \frac{\rho l}{VA}$ (D) $4 \frac{VA}{\rho l}$

Q.103 The four arms of a Wheatstone bridge have resistance as shown in the figure. A galvanometer of 15Ω resistance is connected across BD. Calculate the current through the galvanometer when a potential difference of 10 V is maintained across AC. **[JEE MAIN 2021]**

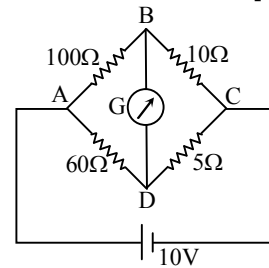

- (A) 2.44 μA (B) 2.44 mA
 (C) 4.87 mA (D) 4.87 μA

- Q.104** In the given circuit of potentiometer, the potential difference E across AB (10 m length) is larger than E_1 and E_2 as well. For key K_1 (closed), the jockey is adjusted to touch the wire at point J_1 so that there is no deflection in the galvanometer. Now the first battery (E_1) is replaced by second battery (E_2) for working by making K_1 open and K_2 closed. The galvanometer gives then null deflection at J_2 . The value of $\frac{E_1}{E_2}$ is $\frac{a}{b}$, where $a =$ _____

[JEE MAIN 2021]

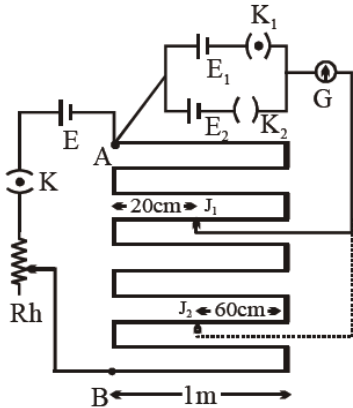

- Q.105** A current of 15 mA flows in the circuit as shown in figure. The value of potential difference between the points A and B will be

[JEE Main 2022]

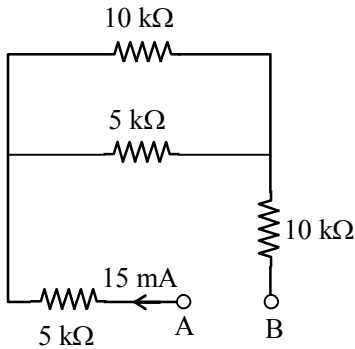

- (A) 50 V (B) 75 V (C) 150 V (D) 275 V

- Q.106** The current density in a cylindrical wire of radius $r = 4.0$ mm is 1.0×10^6 A/m². The current through the outer portion of the wire between radial distances $\frac{r}{2}$ and r is $x\pi$ A; where x is _____

[JEE Main 2022]

- Q.107** In the given circuit 'a' is an arbitrary constant. The value of m for which the equivalent resistance is minimum, will be $\sqrt{\frac{x}{2}}$. The value of x is _____.

[JEE Main 2022]

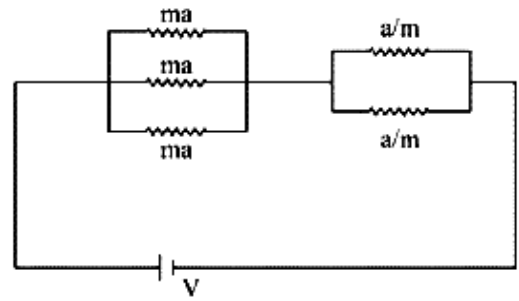

- Q.108** All resistances in figure are 1Ω each. The value of current 'I' is $\frac{a}{5}$ A. The value of a is _____

[JEE Main 2022]

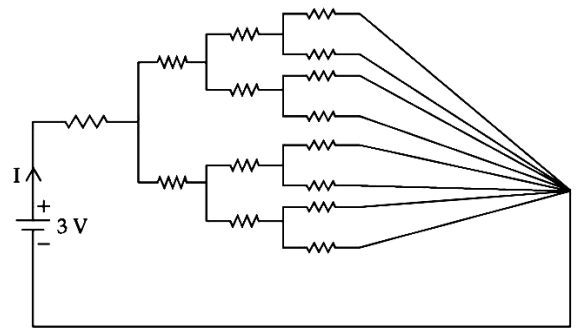

- Q.109** In the given figure, the value of V_0 will be _____ V.

[JEE Main 2022]

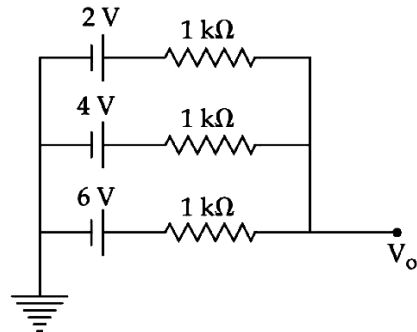

- Q.110** As shown in the figure, a potentiometer wire of resistance 20Ω and length 300 cm is connected with resistance box (R.B.) and a standard cell of emf 4 V. For a resistance 'R' of resistance box introduced into the circuit, the null point for a cell of 20 mV is found to be 60 cm. The value of 'R' is Ω .

[JEE Main 2022]

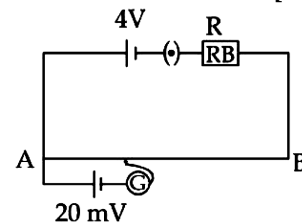

Q.111 An electrical bulb rated 220 V, 100 W, is connected in series with another bulb rated 220 V, 60 W. If the voltage across combination is 220 V, the power consumed by the 100 W bulb will be about ____ W. **[JEE Main 2022]**

Q.112 Equivalent resistance between the adjacent corners of a regular n-sided polygon of uniform wire of resistance R would be **[JEE Main 2023]**

- (A) $\frac{(n-1)R}{(2n-1)}$ (B) $\frac{(n-1)R}{(n^2)}$
 (C) $\frac{(n-1)R}{n}$ (D) $\frac{n^2R}{n-1}$

Q.113 As shown in the figure, a network of resistors is connected to a battery of 24V with an internal resistance of 3Ω . The currents through the resistors R_4 and R_5 are I_4 and I_5 respectively. The values of I_4 and I_5 are: **[JEE Main 2023]**

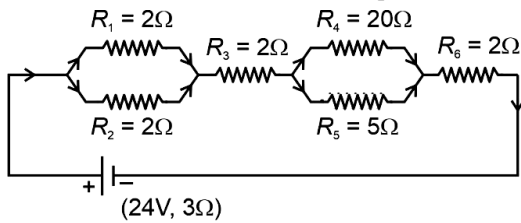

- (A) $I_4 = \frac{8}{5} \text{ A}$ and $I_5 = \frac{2}{5} \text{ A}$
 (B) $I_4 = \frac{24}{5} \text{ A}$ and $I_5 = \frac{6}{5} \text{ A}$
 (C) $I_4 = \frac{2}{5} \text{ A}$ and $I_5 = \frac{8}{5} \text{ A}$
 (D) $I_4 = \frac{6}{5} \text{ A}$ and $I_5 = \frac{24}{5} \text{ A}$

Q.114 A uniform metallic wire carries a current 2 A. When 3.4 V battery is connected across it. The mass of uniform metallic wire is $8.92 \times 10^{-3} \text{ kg}$, density is $8.92 \times 10^3 \text{ kg/m}^3$ and resistivity is $1.7 \times 10^{-8} \Omega\text{-m}$. The length of wire is: **[JEE Main 2023]**

- (A) $\ell = 100 \text{ m}$ (B) $\ell = 6.8 \text{ m}$
 (C) $\ell = 10 \text{ m}$ (D) $\ell = 5 \text{ m}$

Q.115 In the following circuit, the magnitude of current I_1 , is ____ A. **[JEE Main 2023]**

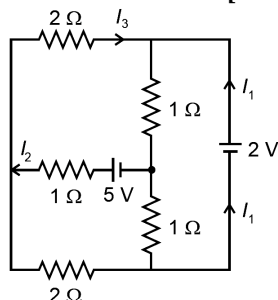

Q.116 A student is provided with a variable voltage source V, a test resistor $R_T = 10\Omega$, two identical galvanometers G_1 and G_2 and two additional resistors, $R_1 = 10M\Omega$ and $R_2 = 0.001 \Omega$. For conducting an experiment to verify ohm's law, the most suitable circuit is: **[JEE Main 2023]**

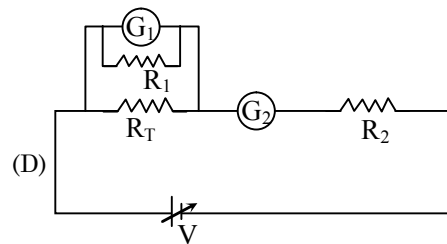
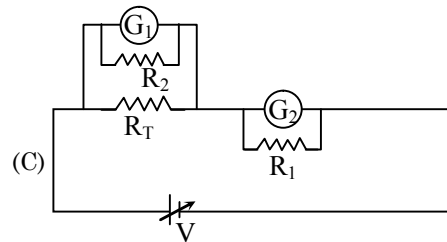
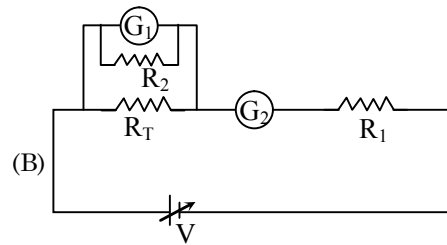
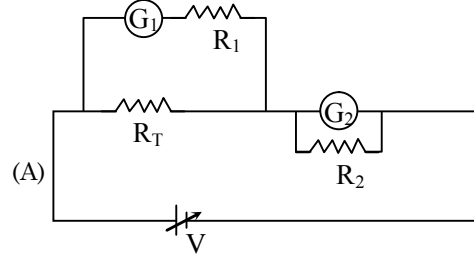

Q.117 In the given figure, the charge stored in $6 \mu\text{F}$ capacitor, when point A and B are joined by a connecting wire is ____ μC . **[JEE Main 2024]**

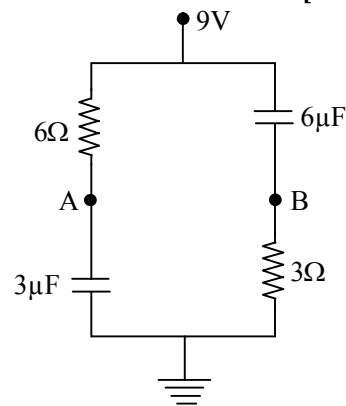

- Q.118** In a metre-bridge when a resistance in the left gap is 2Ω and unknown resistance in the right gap, the balance length is found to be 40 cm. On shunting the unknown resistance with 2Ω , the balance length changes by : **[JEE Main 2024]**
 (A) 22.5 cm (B) 20 cm
 (C) 65 cm (D) 62.5 cm

- Q.119** To measure the temperature coefficient of resistivity α of a semiconductor, an electrical arrangement shown in the figure is prepared. The arm BC is made up of the semiconductor. The experiment is being conducted at 25°C and resistance of the semiconductor arm is $3\text{m}\Omega$. Arm BC is cooled at a constant rate of $2^\circ\text{C}/\text{s}$. If the galvanometer G shows no deflection after 10 s, then α is : **[JEE Main 2024]**

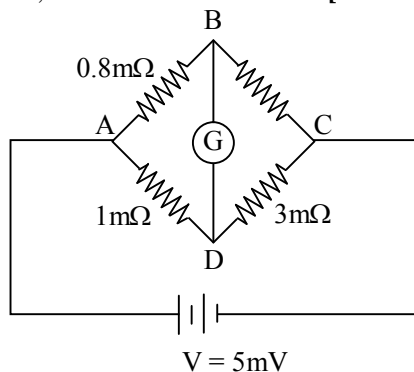

- (A) $-1 \times 10^{-2} \text{ }^\circ\text{C}^{-1}$ (B) $-2.5 \times 10^{-2} \text{ }^\circ\text{C}^{-1}$
 (C) $-1.5 \times 10^{-2} \text{ }^\circ\text{C}^{-1}$ (D) $-2 \times 10^{-2} \text{ }^\circ\text{C}^{-1}$

- Q.120** The reading in the ideal voltmeter (V) shown in the given circuit diagram is : **[JEE Main 2024]**

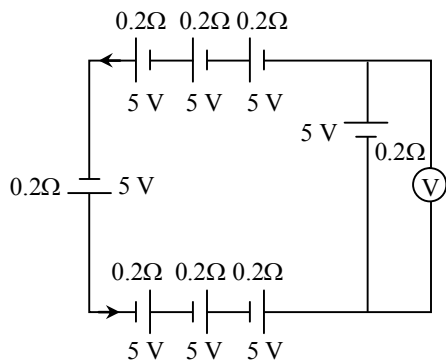

- (A) 0 V (B) 5 V
 (C) 10 V (D) 3 V

- Q.121** A 16Ω wire is bent to form a square loop. A 9V battery with internal resistance 1Ω is connected across one of its sides. If a $4\mu\text{F}$ capacitor is connected across one of its diagonals, the energy stored by the capacitor will be $\frac{x}{2}\mu\text{J}$. Where $x =$ _____.

[JEE Main 2024]

- Q.122** To measure the internal resistance of a battery, potentiometer is used. For $R = 10\Omega$, the balance point is observed at $\ell = 500\text{cm}$ and for $R = 1\Omega$ the balance point is observed at $\ell = 400\text{cm}$. The internal resistance of the battery is approximately : **[JEE Main 2024]**

- (A) 0.2Ω (B) 0.4Ω
 (C) 0.1Ω (D) 0.3Ω

EXERCISE (Level-4)

Part-A : Multiple correct answer type questions

- Q.1** Two circuits (as shown in figure) are called circuit A and circuit B. The equivalent resistance of circuit A is x and that of circuit B is y between 1 and 2.

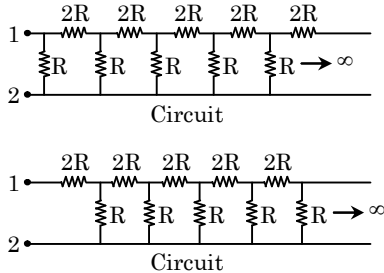

- (A) $y > x$ (B) $y = (\sqrt{3} + 1) R$
 (C) $xy = 2R^2$ (D) $y - x = 2R$

- Q.2** Study the following circuit diagram in figure and mark the correct options.

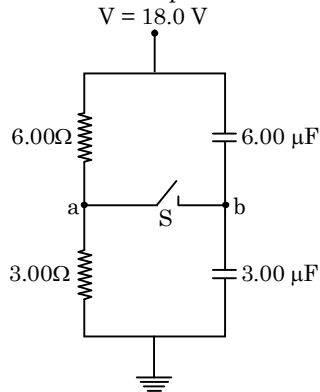

- (A) The potential of point a with respect to point b in the figure when switch S is open is $-6V$.
 (B) The points a and b are at the same potential, when S is opened.
 (C) The charge flowing through switch S when it is closed is $54 \mu C$.
 (D) The final potential of b with respect to ground when switch S is closed is $8 V$.

- Q.3** In the given circuit (as shown in figure)

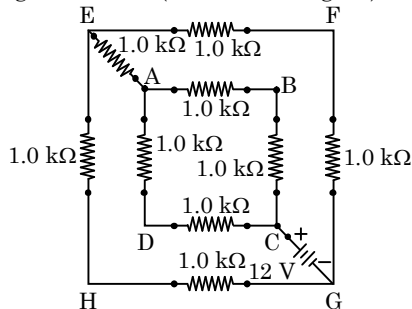

- (A) the equivalent resistance between C and G is $3 k\Omega$.

- (B) the current provided by the source is 4 mA
 (C) the current provided by the source is 8 mA
 (D) voltage across points G and E is $4 V$

- Q.4** In the circuit shown in figure, mark the correct option.

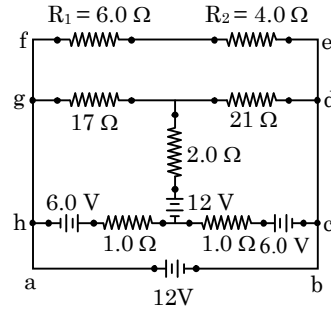

- (A) potential drop across R_1 is $3.2 V$
 (B) Potential drop across R_2 is $5.4 V$
 (C) Potential drop across R_1 is $7.2 V$
 (D) Potential drop across R_2 is $4.8 V$

- Q.5** Consider a simple circuit shown in figure stands for a variable resistance R' . R' can vary from R_0 to infinity, r is internal resistance of the battery ($r \ll R \ll R'$).

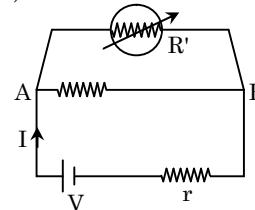

- (A) Potential drop across, AB is nearly constant as R' is varied
 (B) Current through R' is nearly a constant as R' is varied
 (C) Current I depends sensitively on R'
 (D) $I \geq \frac{V}{r + R}$ always

- Q.6** When no current is passed through a conductor—

- (A) the free electrons do not move
 (B) the average speed of free electrons over a large period of time is zero
 (C) the average velocity of free electrons over a large period of time is zero
 (D) the average of the velocities of all the free electrons at an instant is zero

- Q.7** A current passes through a wire of non-uniform cross-section. Which of the following quantities are independent of the cross-section —

- (A) the charge crossing in a given time interval
 (B) drift velocity
 (C) current density
 (D) free-electron density

- Q.8** Two resistors having equal resistances are joined in series and a current is passed through the combination. Neglect any variation of resistance as a temperature change. In a given time interval—
 (A) equal amounts of thermal energy must be produced in the resistors
 (B) unequal amounts of thermal energy may be produced
 (C) the temperature must rise equally in the resistors
 (D) the temperature may rise equally in the resistors

- Q.9** Two fuse wire of rating 10 A and 20 A are connected in different type. Then —
 (A) In parallel combination works as a fuse of 30 A
 (B) In parallel combination works as a fuse of 10 A
 (C) In series combination works as a fuse of 10 A
 (D) In series combination works as a fuse of 20 A

- Q.10** In a potentiometer wire experiment the emf of a battery in the primary circuit is 20 Volt and its internal resistance is $5\ \Omega$. There is a resistance box (in series with the battery and the potentiometer wire) whose resistance can be varied from $120\ \Omega$ to $170\ \Omega$. Resistance of the potentiometer wire is $75\ \Omega$. The following potential difference can be measured using this potentiometer—
 (A) 5V (B) 6V (C) 7V (D) 8V

- Q.11** In the given potentiometer circuit, the resistance of the potentiometer wire AB is R_0 . C is a cell of internal resistance r . The galvanometer G does not give zero deflection for any position of the jockey J. Which of the following cannot be a reason for this ?

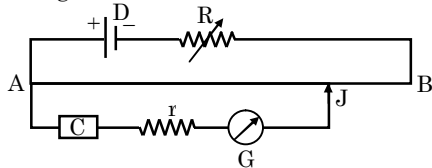

- (A) $r > R_0$
 (B) $R \gg R_0$
 (C) emf of C > emf of D
 (D) The negative terminal of C is connected to A

- Q.12** In the circuit shown the readings of ammeter and voltmeter are 4 A and 20 V respectively. The meters are non ideal, then R is -

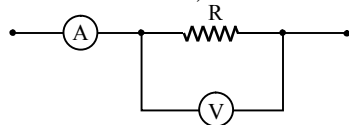

- (A) $5\ \Omega$ (B) less than $5\ \Omega$
 (C) greater than $5\ \Omega$ (D) between $4\ \Omega$ & $5\ \Omega$

- Q.13** The value of the resistance R in figure is adjusted such that power dissipated in the $2\ \Omega$ resistor is maximum. Under this condition -

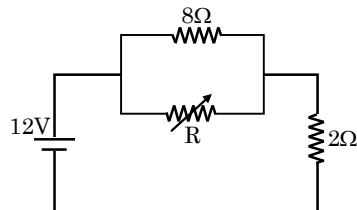

- (A) $R = 0$
 (B) $R = 8\ \Omega$
 (C) Power dissipated in the $2\ \Omega$ resistor is 72 W
 (D) Power dissipated in the $2\ \Omega$ resistor is 8 W

- Q.14** In the circuit shown, current in different branches are marked. Select the correct alternatives -

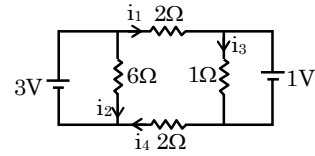

- (A) $i_1 = \frac{1}{2}\ \text{A}$ (B) $i_4 = \frac{1}{2}\ \text{A}$
 (C) $i_2 = \frac{1}{2}\ \text{A}$ (D) $i_3 = 1\ \text{A}$

- Q.15** In a potentiometer circuit, a uniform wire of 10 m having resistance $20\ \Omega$ is fixed between A and B as shown in fig. Neglecting resistance of connecting wires, select the correct options

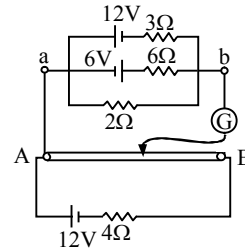

- (A) distance of null point from A is 5m.
 (B) distance of null point from A is 3m
 (C) at null point, current through $4\ \Omega$ is 0.5 A
 (D) at null point, current through $3\ \Omega$ resistor is 3A

- Q.16** In the given networks, the batteries getting charged are

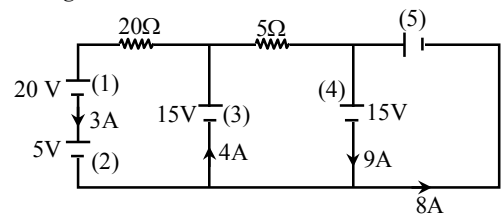

- (A) 1 & 3 (B) 1, 3 & 5
 (C) 1 & 4 (D) 1, 2 & 5

- Q.17** The emf of a cell is :

- (A) the potential difference across its terminals
 (B) the potential difference across its terminals when no current is passing through it
 (C) the heat produced when the cell is connected across a one ohm resistance
 (D) the total work done per coulomb of electricity taken in a circuit in which the cell is connected

Q.18 In the given circuit :

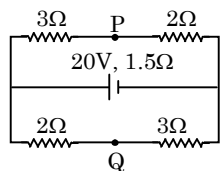

- (A) the current through the battery is 5.0 amp
 (B) P and Q are at the same potential
 (C) P is 2.5 V higher than Q
 (D) Q is 2.5 V higher than P

Part-B : Assertion Reason type Questions

The following questions consists of two statements each, printed as Assertion and Reason. While answering these questions you are to choose any one of the following four responses.

- (A) If both Assertion and Reason are true and the Reason is correct explanation of the Assertion.
 (B) If both Assertion and Reason are true but Reason is not correct explanation of the Assertion.
 (C) If Assertion is true but the Reason is false.
 (D) If Assertion is false but Reason is true.

Q.19 **Assertion :** If the length of the conductor is doubled, the drift velocity will become half of the original value (keeping potential difference unchanged).

Reason : At constant potential difference, drift velocity is inversely proportional to the length of the conductor.

Q.20 **Assertion :** In a chain of bulbs, 50 bulbs are joined in series. One bulb is fused now. If the remains 49 bulbs are again connected in series across the same supply then light gets increased in the room.

Reason : The resistance of 49 bulbs will be less than 50 bulbs.

Q.21 **Assertion :** Current is passed through a metallic wire, heating it red. When cold water in poured on half of its portion, then rest of the half portion becomes more hot.

Reason : Resistance decreases due to decrease in temperature and then current through wire increases.

Q.22 **Assertion:** A domestic electrical appliance, working on a three pin, will continue working even if the top pin is removed.

Reason : The third pin is used only as a safety device.

Q.23 **Assertion :** In parallel combination of electrical appliances, in home circuit total power consumption is equal to the sum of the rated powers of the individual appliances.

Reason : In parallel combination, in home circuit the voltage across each appliance is the same, as required for the proper working of electrical appliance.

Q.24 **Assertion :** When the cell is in the open circuit there is no force on a test charge inside the electrolyte of the cell.

Reason : There is no electric field inside the cell, when the cell is in open circuit.

Q.25 **Assertion :** The emf of the driver cell in the potentiometer experiment should be greater than the e.m.f. of the cell to be determined.

Reason : The fall of potential across the potentiometer wire should not be less than the e.m.f. of the cell to be determined.

Q.26 **Assertion :** A potentiometer of longer length is used for accurate measurement.

Reason : The potential gradient for a potentiometer of longer length with a given source of e.m.f. becomes small.

Part-C : Column Matching type Questions

Q.27 A circuit is shown in figure R is a nonzero variable but finite resistance. e is some unknown emf with polarities as shown. Match the columns.

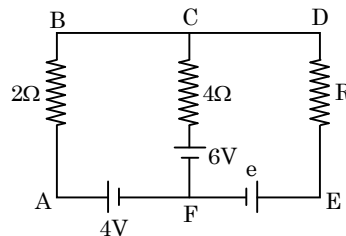

Column-I

- (A) Current passing through 4Ω resistance can be zero.
 (B) Current passing through 4Ω resistance can be from F to C.
 (C) Current passing through 4Ω resistance can be from C to F.
 (D) Current passing through 2Ω resistance will be from B to A.

Column-II

- (P) possible if $e = 6V$
 (Q) possible if $e > 6V$
 (R) possible if $e < 6V$
 (S) possible for any value of e from zero to infinity

Q.28 Two cells of the same emf ' e ' but different internal resistances, r_1 & r_2 are connected in series with an external resistance R .

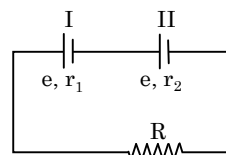

- | Column I | Column II |
|---|---|
| (A) value of current through R | (P) potential drop across second cell is zero |
| (B) when external resistance R is $r_1 - r_2$ | (Q) $\frac{2e}{R + r_1 + r_2}$ |
| (C) when external resistance R is $r_1 + r_2$ | (R) potential drop across first cell is zero |
| (D) when external resistance R is $r_2 - r_1$ | (S) maximum power output across resistance R |

Q.29 Referring to the circuit shown in figure for different values of R effect on various things are given in column-I. Then match Column-I with Column-II.

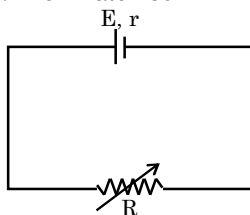

- | Column I | Column II |
|---|------------------|
| (A) Terminal potential difference across the cell will be maximum | (P) $r > R$ |
| (B) Power transferred to resistance R is less than the maximum possible | (Q) $r < R$ |
| (C) Power dissipated in the cell is maximum | (R) $R = \infty$ |
| (D) Fastest drift of ions in the electrolyte in the cell will be for | (S) $R = 0$ |

Part-D : Passage based objective questions

Passage # 1 (Q.30 to 32)

Consider the circuit shown in figure

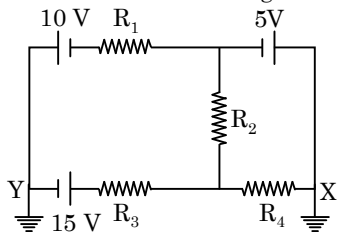

- Q.30** Current through R_2 is zero if $R_4 = 2\Omega$ and $R_3 = 4\Omega$. In this case -
 (A) current through $R_3 = 2.5$ A
 (B) current through $R_4 = 3$ A
 (C) both (a) and (b) are correct
 (D) both (a) and (b) are wrong
- Q.31** Assuming $R_1 = 2\Omega$, current passing through resistance R_1 is -
 (A) 2A (B) 2.5 A (C) 3.5 A (D) zero

- Q.32** Assuming $R_1 = 2\Omega = R_4$, $R_3 = 4\Omega$, current passing through the circuit if resistance R_2 is removed is (remove ground connection at point X)
 (A) 2A (B) 3A (C) 1A (D) 2.5A

Passage # 2 (Q. 33 to 37)

In the laboratory, the voltage across a particular circuit element can be measured by a voltmeter. A voltmeter has a very high resistance and should be connected in parallel to the circuit element whose voltage is being measured. Connected improperly, the voltmeter will affect the circuit, interrupting it and preventing current from flowing through the circuit element that it is meant to measure. An experiment is conducted in which a voltmeter is used to investigate voltages in a circuit containing a capacitor and a light bulb. The bulb and the capacitor are connected in series with a battery and the voltmeter is placed in different positions : in the first case across the capacitor, in the second case across the light bulb, and in the third case across the battery (see figure 1). The voltmeter reading is recorded every 10 seconds. The voltage for Case 1 as a function of time is shown in figure 2.

Case 1

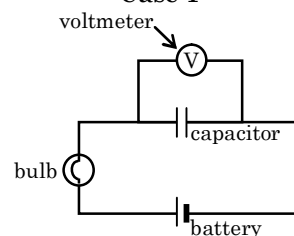

Case 2

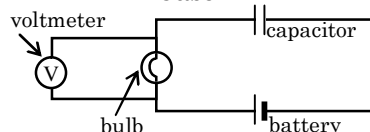

Case 3

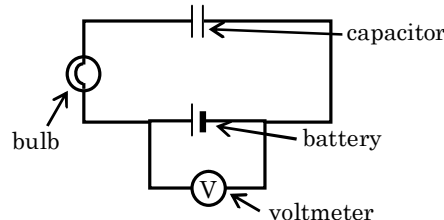

Figure - 1

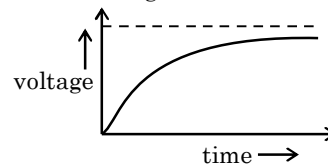
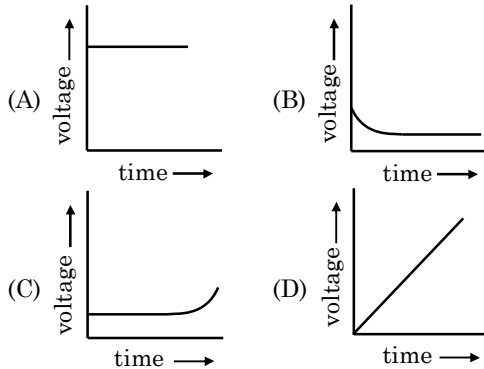

Figure - 2

(Note : Assume that the battery has no internal resistance and that the resistance of the light bulb is constant)

- Q.33** In the circuit shown in figure 1, which of the following conditions would indicate that the capacitor was fully charged –
- A voltmeter connected across the capacitor reads a constant voltage.
 - The light bulb in the circuit stops shining.
 - The voltage across the bulb equals the voltage across the battery
- (A) I only (B) III only
(C) I and II only (D) I, II, and III

- Q.34** Which one of the following graphs could correctly represent the voltage across the battery as a function of time during the experiment described in the passage ?



- Q.35** How will the voltage across the light bulb vary with time as the capacitor is charging–
- It will decrease, because as the capacitor plates fill with charge, they will impede further charge, which will decrease the current and the voltage across the bulb
 - It will remain the same, because as the capacitor plates fill with charge and impede the current, the voltage output of the battery will increase to keep the current constant
 - It will increase, because as the capacitor plates fill with charge, they will induce further charge, which will create a greater voltage across the bulb
 - It will increase, because as the capacitor plates fill with charge, the voltage across the capacitor will decrease, and therefore the voltage across the light bulb will increase

- Q.36** The light bulb shown in figure 1 is replaced first with two identical resistors in series, and then with the same two resistors in parallel. The total time taken for the capacitor to charge is measured in both cases, and found to be longer for the first case. It can be deduced that –
- When the resistance of the circuit is increased, the capacitance of the capacitor increases
 - the presence of resistors affects the final voltage across the capacitor plates
 - more charge is absorbed by the resistors as the resistance of the circuit increases
 - the presence of resistors hinders the flow of charge, thus reducing the current in the circuit

- Q.37** In the diagram below, a voltmeter is connected in series to a circuit that includes a battery and two bulbs in series. The bulbs, which had been shining in the absence of the voltmeter immediately stop shining. How might the circuit be modified in order to make the bulbs shine steadily again with their former brilliance without removing the voltmeter ?

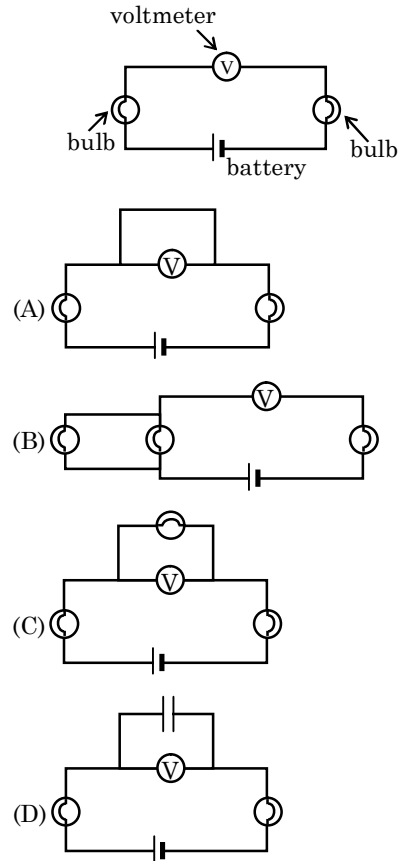

Passage # 3 (Q.38 to 40)

Figure shows a network of resistors and a battery. If 1A current flows through the branch CF, then answer the following question.

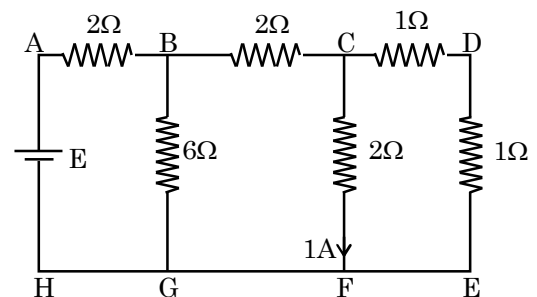

- Q.38** The current through –
- Branch DE is 1A
 - Branch BC is 2A
 - Branch BG is 4A
 - A & B both

- Q.39** In the above circuit if a zero resistance wire is connected in parallel to branch CF. Then the current through -

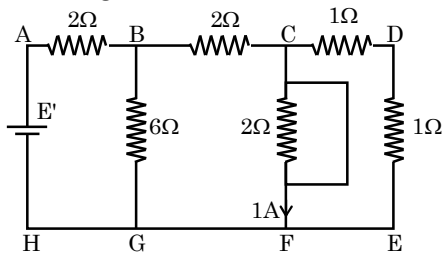

- (A) Branch DE is 0.5A (B) Branch BC is 1A
(C) Branch BG is 0.5A (D) Branch AB is 1.5A

- Q.40** The emf E' of the battery in the **question 39**.

- (A) 9 V (B) 12 V (C) $\frac{14}{3}$ V (D) 16 V

Passage # 4 (Q.41 to 43)

A 12-volt battery is connected to two light bulbs as drawn in fig. 1 light bulb 1 has resistance 3 ohms, while light bulb 2 has resistance 6 ohms. The battery has essentially no internal resistance, and all the wires are essentially resistanceless, too.

When a light bulb is unscrewed, no current flows through that branch of the circuit. For instance, if light bulb 2 is unscrewed, current flows only around the lower loop of the circuit, which consists of the battery and light bulb 1. The more current flows through a light bulb, their equivalent resistance is $R_{eq} = R_1 + R_2$. By contrast, when two resistors are wired in parallel, their net resistance is given by.

$$\frac{1}{R_{eq}} = \frac{1}{R_1} + \frac{1}{R_2}$$

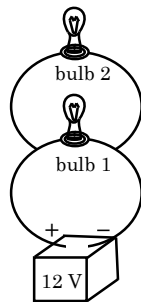

- Q.41** With only light bulb 1 screwed in, a 12-volt battery goes dead in 24 days. With both light bulbs screwed in, a 12-volt battery goes dead in
(A) 12 days (B) 14 days
(C) 16 days (D) 18 days
- Q.42** Bulb 2 is now screwed in As a result, bulb 1
(A) turns off
(B) becomes dimmed
(C) stays about the same brightness
(D) becomes brighter

- Q.43** With both light bulbs screwed in, the current through the battery is
(A) 1.2 amperes (B) 2 amperes
(C) 4 amperes (D) 6 amperes

Part-E: Numerical Response/Subjective Type Qs.

- Q.44** A long resistor between A and B as shown in fig. has resistance of 300 Ω and is tapped at one-third points.

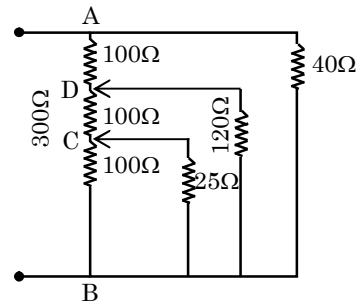

- (a) What is the equivalent resistance between points A and B?
(b) If the p.d. between A and B is 320 V, what will be the p.d. between B and C?
(c) Will the answer of part (b) change if the 40 Ω resistor is disconnected?

- Q.45** Find the value of n if current flowing through the resistance R_1 of the circuit shown in fig is $n \times 10^{-1}$ if the resistance are equal to $R_1 = 10 \Omega$, $R_2 = 20 \Omega$ and $R_3 = 30 \Omega$ and potentials of points 1, 2 and 3 are equal to $V_1 = 10$ V, $V_2 = 6$ V and $V_3 = 5$ V.

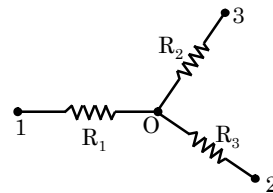

- Q.46(a)** N sources of current with different emfs are connected as shown in fig. The emfs of the sources are proportional to their internal resistances, i.e. $E = \alpha R$, where α is an assigned constant. The lead wire resistance is negligible, find:

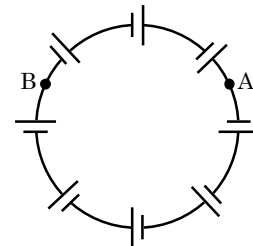

- (i) the current in the circuit;
(ii) the potential difference between points A and B dividing the circuit in n and $N - n$ links.

- (b) The internal resistance of an accumulator battery of emf 6 V is $10\ \Omega$ when it is fully discharged. As the battery gets charged up, its internal resistance decreases to $1\ \Omega$. The battery in its completely discharged state is connected to a charger which maintains a constant potential difference of 9 V. Find the current through the battery (a) just after the connections are made and (b) after a long time when it is completely charged.

Q.47(a) In the given figure, calculate the potential of the points M and N if $E = 12\text{V}$, $R_1 = 3\Omega$, $R_2 = 2\Omega$ and $r = 1\Omega$.

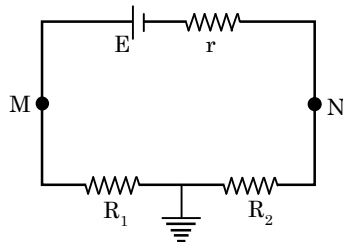

- (b) The efficiency of a cell whose internal resistance is 1Ω when connected to a external resistance R is 60%. What will be its efficiency if the external resistance is increased six times ?

Q.48 An electric kettle used to prepare tea, takes 2 minutes to boil 4 cups of water (1 cup contains 200 cc of water) if the room temperature is 25°C . (a) If the cost of power consumption is Rs. 1.00 per unit (1 unit = 1000 watt-hour), calculate the cost of boiling 4 cups of water. (b) What will be the corresponding cost if the room temperature drops to 5°C ?

Q.49 A resistance coil, connected to an external battery, is placed inside an adiabatic cylinder fitted with a frictionless piston and containing an ideal gas. A current $i = 2\text{A}$ flows through the coil, which has a resistance $R = 10\Omega$. At what speed v (in m/s) must the piston move upward in order that the temperature of the gas may remain unchanged. (Assume atmosphere pressure is to be zero). $g = 10\text{ m/s}^2$

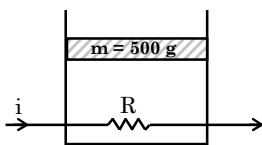

Q.50 There are several cells each of e.m.f. 2V and internal resistance $0.5\ \Omega$. It is desired to obtain a maximum current of 8 A from their combination in an external resistance of $5\ \Omega$.

- (a) Calculate the minimum no. of cells required for this purpose, and
(b) How they should be grouped.

Q.51(a) A conductor has a temperature-independent resistance R and a total heat capacity C . At the moment $t = 0$ it is connected to a dc voltage V . Find the time dependence of the conductor's temperature T , assuming the thermal power

dissipated into surrounding space to vary as $q = K(T - T_0)$, where K is a constant, T_0 is the environmental temperature (equal to the conductors temperature at the initial moment).

- (b) A resistance R carries a current I . At steady state the rate of heat loss to the surroundings is $\lambda(T - T_0)$ where λ is a constant. T is the temperature of the resistance and T_0 is the temperature of the atmosphere. If the coefficient of linear expansion is α , then find strain in the resistance at steady state.

$$\left(\text{strain} = \frac{\text{change in length}}{\text{original length}}\right)$$

Q.52 A battery consists of twelve cells in series, each cell having an e.m.f. E and internal resistance. Some of the cells in the battery are connected with wrong polarity. This battery is connected to another source of e.m.f. $2E$ and internal resistance $2r$. An ammeter in the circuit reads 3 amp when battery and the source aid each other and 2 amp in the same direction when they oppose each other. Find how many cells in the battery are connected with wrong polarity.

Q.53 Consider an infinite ladder network.

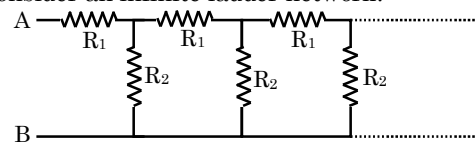

A voltage is applied between points A & B. If the voltage is halved after each section. Find the ratio R_2/R_1 .

Q.54 Two batteries of emf E_1 and E_2 a capacitor of capacitance C , and a resistor of resistance R are connected in a circuit as shown in Fig. Determine the amount of heat Q (in μJ) liberated in the resistor after shifting the key K from A to B.

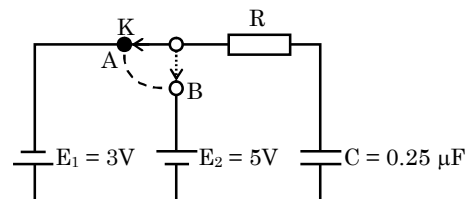

Q.55 The capacitor shown in fig. has been charged to a p.d. of V volt so that it carries a charge CV with both the switches S_1 and S_2 remaining open. Switch S_1 is closed at $t = 0$. At $t = R_1C$, switch S_1 is opened and S_2 is closed. Find the charge on the capacitor at $t = 2R_1C + R_2C$.

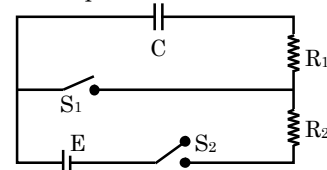

- Q.56** If key K is shifted from a to b then after how many time constants will the energy stored in the capacitor in Fig. reach $\frac{1}{e^4}$ times of its equilibrium value ?

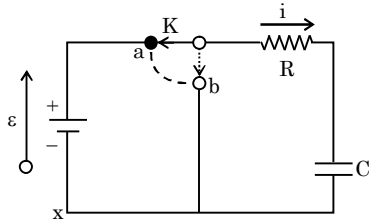

- Q.57** A voltmeter coil has resistance 50.0Ω and a resistor of $1.15 \text{ k}\Omega$ is connected in series. It can read potential differences upto 12 volts. If this same coil is used to construct an ammeter which can measure currents upto 260 mA, what should be the resistance of the shunt used ? If it is $0.5 \times n$. Find n.
- Q.58** A voltmeter of resistance R_V and an ammeter of resistance R_A are connected in series across a battery of emf E and of negligible internal resistance. When a resistance R is connected in parallel to voltmeter, reading of ammeter increases to three times while that of voltmeter reduces to one-third. If $R_V = \lambda R_A$. Find value of λ .
- Q.59** A hemisphere network of radius $a = 2 \text{ cm}$ is made by using a conducting wire of resistance per unit length $r = 0.8 \Omega/\text{cm}$. Find the equivalent resistance across OP.

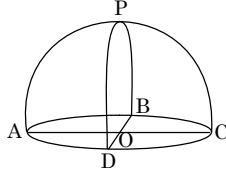

- Q.60** Potential difference $V_B - V_A$ for the circuit shown in the figure, is given by $\frac{22}{3\lambda} \text{ V}$. Find λ .

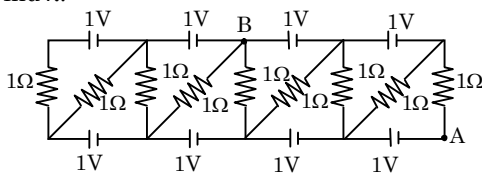

- Q.61** In the primary circuit of potentiometer the rheostat can be varied from 0 to 10Ω . Initially it is at minimum resistance (zero).

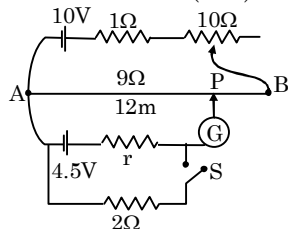

- (a) Find the length AP of the wire such that the galvanometer shows zero deflection.
 (b) Now the rheostat is put at maximum resistance (10Ω) and the switch S is closed. New balancing length is found to be 8 m. Find the internal resistance r of the 4.5V cell.

- Q.62** Figure shows a potentiometer with a cell of emf 2.0 V and internal resistance 0.04Ω maintaining a potential drop across the resistor wire AB. A standard cell which maintains a constant emf of 1.02 V (for very moderate currents up to a few ampere) gives a balance point of 67.3 cm length of the wire. To ensure very low currents drawn from the standard cell, a very high resistance of $600 \text{ k}\Omega$ is put in series with it which is shorted close to the balance point. The standard cell is then replaced by a cell of unknown emf E and the balance point found similarly turns out to be at 82.3 cm length of the wire.

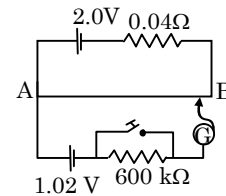

- (a) What is the value of E
 (b) What purpose does the high resistance of $600 \text{ k}\Omega$ have?
 (c) Is the balance point affected by this high resistance?
 (d) Is the balance point affected by internal resistance of the driver cell?
 (e) Would the method work in the above situation if the driver cell of the potentiometer had an emf of 1.0V instead of 2.0 V ?

- Q.63** A resistor R placed in a circuit in series with the other resistor totaling 50Ω alters the current in the circuit by 0.5 Ampere. When it is placed in parallel with the other resistors, the current alters by 1 amp, find the value of R.

- Q.64** A total charge Q flows across a resistor R during a time interval = T in such a way that the current versus time graph for $0 \rightarrow T$ is like the loop of a sin curve in the range $0 \rightarrow \pi$. Find the total heat generated in the resistor.

EXERCISE (Level-5)

Old Examination Questions [JEE Advanced]

- Q.1** In the given circuit the switch S is closed at time $t = 0$. The charge Q on the capacitor at any instant t is given by $Q(t) = Q_0(1 - e^{-\alpha t})$. Find the value of Q_0 and α in terms of given parameters as shown in the circuit. **[IIT-JEE 2005]**

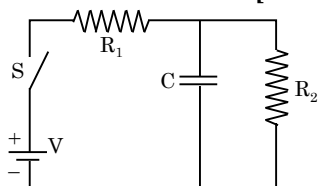

- Q.2** An unknown resistance is to be determined using resistance R_1 , R_2 , and R_3 . If their corresponding null points are A, B and C. Which of the following will give most accurate reading? **[IIT-JEE 2005]**

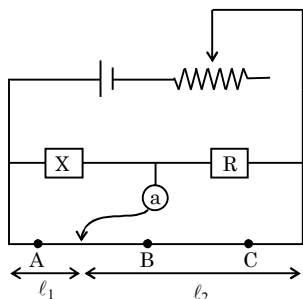

- Q.3** A galvanometer having Resistance 100Ω is used to form an ammeter with the help of resistance 0.1Ω . The maximum deflection of galvanometer is at $100 \mu\text{A}$. Find the smallest current when Galvanometer shows maximum deflection- **[IIT-JEE 2005]**
- (A) 100.1 mA (B) 1000.1 mA
 (C) 10.01 mA (D) 1.001 mA

- Q.4** A $4 \mu\text{F}$ capacitor, a resistance of $2.5 \text{ M}\Omega$ is in series with 12 V battery. Find the time after which the potential difference across the capacitor is 3 times the potential difference across the resistor **[IIT-JEE 2005]**
- [Given $\ln(2) = 0.693$]
 (A) 13.86 s (B) 6.93 s (C) 7 s (D) 14 s

- Q.5** An ideal gas is filled in a closed rigid and thermally insulated container. A coil of 100Ω resistor carrying current 1A for 5 minutes supplies heat to the gas. The change in internal energy of the gas is - **[IIT-JEE 2005]**
- (A) 10 kJ (B) 30 kJ (C) 20 kJ (D) 0 kJ

- Q.6** Consider a cylindrical element as shown in the figure. Current flowing through element is I and resistivity of material of the cylinder is ρ . Choose the correct option out of the following - **[IIT-JEE 2006]**

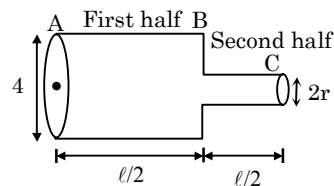

- (A) Power loss in second half is four times the power loss in first half
 (B) Voltage drop in first half is twice of voltage drop in second half
 (C) Current density in both halves are equal
 (D) Electric field in both halves is equal
- Q.7** Time constant for the given circuits are - **[IIT-JEE 2006]**

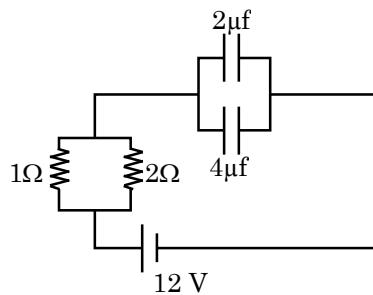
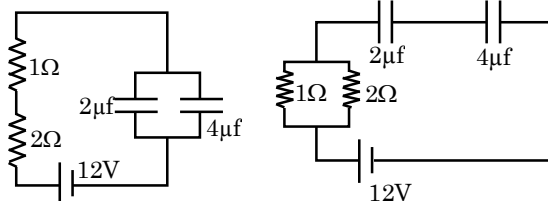

- (A) $18 \mu\text{s}$, $\frac{8}{9} \mu\text{s}$, $4 \mu\text{s}$ (B) $18 \mu\text{s}$, $4 \mu\text{s}$, $\frac{8}{9} \mu\text{s}$
 (C) $4 \mu\text{s}$, $\frac{8}{9} \mu\text{s}$, $18 \mu\text{s}$ (D) $\frac{8}{9} \mu\text{s}$, $18 \mu\text{s}$, $4 \mu\text{s}$

- Q.8** A parallel plate capacitor C with plates of unit area and separation d is filled with a liquid of dielectric constant $K = 2$. The level of liquid is $d/3$ initially. Suppose the liquid level decreases at a constant speed V , the time constant as a function of time t is - **[IIT-JEE 2008]**

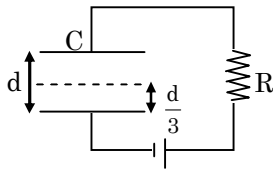

- (A) $\frac{6\epsilon_0 R}{5d + 3Vt}$ (B) $\frac{(15d + 9Vt)\epsilon_0 R}{2d^2 - 3dVt - 9V^2 t^2}$
 (C) $\frac{6\epsilon_0 R}{5d - 3Vt}$ (D) $\frac{(15d - 9Vt)\epsilon_0 R}{2d^2 + 3dVt - 9V^2 t^2}$

- Q.9** Figure shows three resistor configurations R_1 , R_2 and R_3 connected to 3V battery. If the power dissipated by the configuration R_1 , R_2 and R_3 is P_1 , P_2 and P_3 , respectively, then **[IIT-JEE 2008]**

Figure :

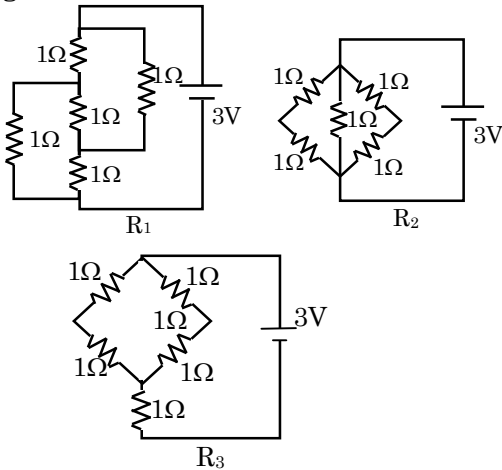

- (A) $P_1 > P_2 > P_3$ (B) $P_1 > P_3 > P_2$
 (C) $P_2 > P_1 > P_3$ (D) $P_3 > P_2 > P_1$

Statement type Question : (Q.10 to 11)

- (A) Statement-1 is True, Statement-2 is True; Statement-2 is a correct explanation for Statement-1
 (B) Statement-1 is True, Statement-2 is True; Statement-2 is NOT a correct explanation for Statement-1
 (C) Statement-1 is True, Statement-2 is False
 (D) Statement-1 is False, Statement-2 is True

- Q.10** **Statement-1** : In a Meter Bridge experiment, null point for an unknown resistance is measured. Now, the unknown resistance is put inside an enclosure maintained at a higher temperature.

The null point can be obtained at the same point as before by decreasing the value of the standard resistance.

Statement-2 : Resistance of a metal increases with increase in temperature. **[IIT-JEE 2008]**

- Q.11** **Statement-1** : For practical purposes the earth is used as a reference at zero potential in electrical circuits.

Statement-2 : The electrical potential of a sphere of radius R with charge Q uniformly distributed on the surface is given by $\frac{Q}{4\pi\epsilon_0 R}$. **[IIT-JEE 2008]**

- Q.12** **Column II** gives certain systems undergoing a process. **Column I** suggests changes in some of the parameters related to the system. Match the statements in **Column I** to the appropriate process(es) from **Column II**. **[IIT-JEE 2009]**

	Column I	Column II
(A)	The energy of the system is increased	(P) System : A capacitor, initially uncharged Process : it is connected to a battery
(B)	Mechanical energy is provided to the system, which is converted into energy of random motion of its parts	(Q) System : A gas in an adiabatic container fitted with an adiabatic piston. Process : The gas is compressed by pushing the piston
(C)	Internal energy of the system is converted into its mechanical energy	(R) System : A gas in a rigid container Process : The gas gets cooled due to colder atmosphere surrounding it
(D)	Mass of the system is decreased	(S) System : A heavy nucleus, initially at rest Process : The nucleus fissions into two fragments of nearly equal masses and some neutrons are emitted
		(T) System : A resistive wire loop Process : The loop is placed in a time varying magnetic field perpendicular to its plane

- Q.13** For the circuit shown in the figure **MCQ [IIT-JEE 2009]**

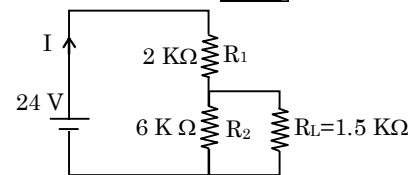

- (A) the current I through the battery is 7.5 mA
 (B) the potential difference across R_L is 18 V
 (C) ratio of powers dissipated in R_1 and R_2 is 3
 (D) if R_1 and R_2 are interchanged, magnitude of the power dissipated in R_1 , will decrease by a factor of 9.

- Q.14** Consider a thin square sheet of side L and thickness t , made of a material of resistivity ρ . The resistance between two opposite faces, shown by the shaded areas in the figure is – **[IIT-JEE 2010]**

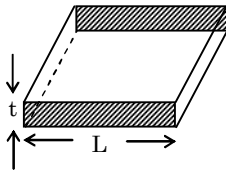

- (A) directly proportional to L
 (B) directly proportional to t
 (C) independent of L
 (D) independent of t
- Q.15** Incandescent bulbs are designed by keeping in mind that the resistance of their filament increases with the increase in temperature. If at room temperature, 100 W, 60 W and 40 W bulbs have filament resistances R_{100} , R_{60} and R_{40} , respectively, the relation between these resistances is- **[IIT-JEE 2010]**
- (A) $\frac{1}{R_{100}} = \frac{1}{R_{40}} + \frac{1}{R_{60}}$ (B) $R_{100} = R_{40} + R_{60}$
 (C) $R_{100} > R_{60} > R_{40}$ (D) $\frac{1}{R_{100}} > \frac{1}{R_{60}} + \frac{1}{R_{40}}$
- Q.16** To verify Ohm's law, student is provided with a test resistor R_T , a high resistance R_1 , a small resistance R_2 , two identical galvanometers G_1 and G_2 , and a variable voltage source V . The correct to carry out the experiment is - **[IIT-JEE 2010]**

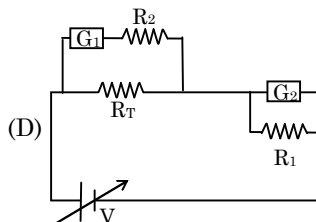
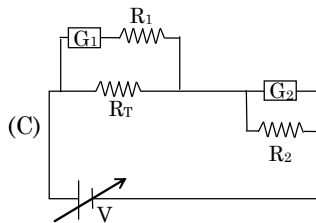
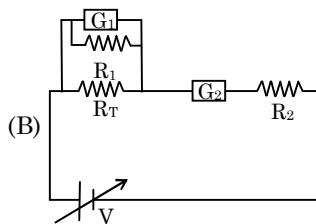
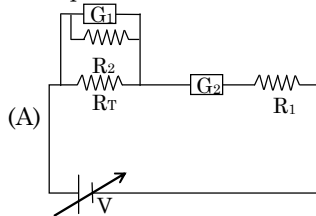

- Q.17** When two identical batteries of internal resistance 1Ω each are connected in series across a resistor R , the rate of heat produced in R is J_1 . When the same batteries are connected in parallel across R , the rate is J_2 . If $J_1 = 2.25 J_2$ then the value of R is Ω is? **[IIT-JEE 2010]**

- Q.18** At time $t = 0$, a battery of 10 V is connected across points A and B in the given circuit. If the capacitors have no charge initially, at what time (in seconds) does the voltage across them become 4 V? (Take: $\ln 5 = 1.6$, $\ln 3 = 1.1$) **[IIT-JEE 2010]**

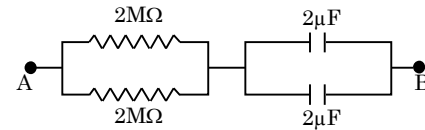

- Q.19** A meter bridge is set-up as shown, to determine an unknown resistance 'X' using a standard 10 ohm resistor. The galvanometer show null point when tapping-key is at 52 cm mark. The end-corrections are 1 cm and 2 cm respectively for the ends A and B. The determine value of 'X' is - **[IIT-JEE 2011]**

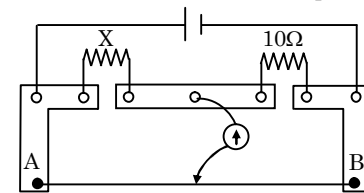

- (A) 10.2 ohm (B) 10.6 ohm (C) 10.8 ohm (D) 11.1 ohm
- Q.20** Two batteries of different emfs and different internal resistances are connected as shown. The voltage across AB in volts is - **[IIT-JEE 2011]**

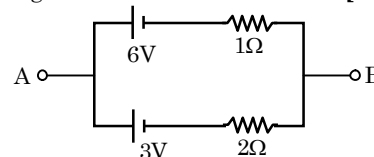

- Q.21** For the resistance network shown in the figure, choose the correct option (s). **MCQ [IIT-JEE 2012]**

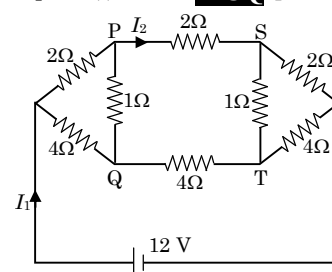

- (A) The current through PQ is zero
 (B) $I_1 = 3A$
 (C) The potential at S is less than that at Q
 (D) $I_2 = 2A$
- Q.22** Two ideal batteries of emf V_1 and V_2 and three resistance R_1 , R_2 and R_3 connected as shown in the figure. The current in resistance R_2 would be zero if **MCQ [JEE-Advance-2014]**

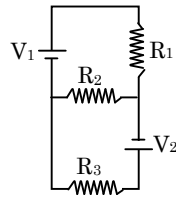

- (A) $V_1 = V_2$ and $R_1 = R_2 = R_3$
 (B) $V_1 = V_2$ and $R_1 = 2R_2 = R_3$
 (C) $V_1 = 2V_2$ and $2R_1 = 2R_2 = R_3$
 (D) $2V_1 = V_2$ and $2R_1 = R_2 = R_3$

- Q.23** At time $t = 0$, terminal A in the circuit shown in the figure is connected to B by a key and an alternating current $I(t) = I_0 \cos(\omega t)$, with $I_0 = 1\text{ A}$ and $\omega = 500\text{ rad s}^{-1}$ starts flowing in it with the initial direction shown in the figure. At $t = 7\pi/6\omega$ the key is switched from B to D. Now onwards only A and D are connected. A total charge Q flows from the battery to charge the capacitor fully. If $C = 20\ \mu\text{F}$, $R = 10\ \Omega$ and the battery is ideal with emf of 50 V , identify the correct statement (s). **MCQ [JEE-Advance-2014]**

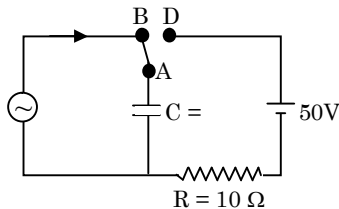

- (A) Magnitude of the maximum charge on the capacitor before $t = 7\pi/6\omega$ is $1 \times 10^{-3}\text{ C}$.
 (B) The current in the left part of the circuit just before $t = 7\pi/6\omega$ is clockwise.
 (C) Immediately after A is connected to D, the current in R is 10 A .
 (D) $Q = 2 \times 10^{-3}\text{ C}$.

- Q.24** A galvanometer gives full scale deflection with 0.006 A current. By connecting it to a $4990\ \Omega$ resistance, it can be converted into a voltmeter of range $0\text{-}30\text{ V}$. If connected to a $\frac{2n}{249}\ \Omega$ resistance, it becomes an ammeter of range $0\text{-}1.5\text{ A}$. The value of n is. **[JEE-Advance-2014]**

- Q.25** Heater of an electric kettle is made of a wire of length L and d . it takes 4 minutes to raise the temperature of 0.5 kg water by 40 K . This heater is replaced by a new heater having two wires of the same material each of length L and diameter $2d$. The way these wires are connected is given in the options. How much time in minutes will it take to raise the temperature of the same amount of water by 40 K ?

MCQ [JEE-Advance-2014]

- (A) 4 if wires are in parallel
 (B) 2 if wires are in series
 (C) 1 if wires are in the series
 (D) 0.5 if wires are in parallel

- Q.26** In an aluminum (Al) bar of square cross section, a square hole is drilled and is filled with iron (Fe) as shown in the figure. The electrical resistivities of Al and Fe are $2.7 \times 10^{-8}\ \Omega\text{m}$ and $1.0 \times 10^{-7}\ \Omega\text{m}$, respectively. The electrical resistance between the two faces P and Q of the composite bar is **[JEE-Advance-2015]**

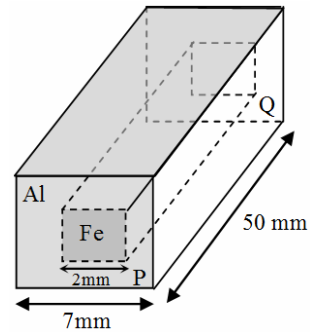

- (A) $\frac{2475}{64}\ \mu\Omega$ (B) $\frac{1875}{64}\ \mu\Omega$
 (C) $\frac{1875}{49}\ \mu\Omega$ (D) $\frac{2475}{132}\ \mu\Omega$

- Q.27** In the following circuit, the current through the resistor $R (= 2\ \Omega)$ is I Amperes. The value of I is **[JEE-Advance-2015]**

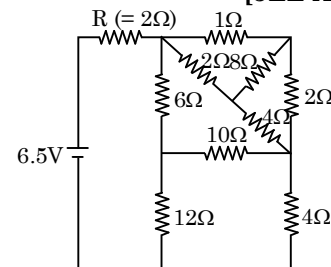

- Q.28** An infinite line charge of uniform electric charge density λ lies along the axis of an electrically conducting infinite cylindrical shell of radius R . At time $t = 0$, the space inside the cylinder is filled with a material of permittivity ϵ and electrical conductivity σ . The electrical conduction in the material follows Ohm's law. Which on the following graphs best describes the subsequent variation of the magnitude of current density $j(t)$ at any point in the material. **[JEE-Advance-2016]**

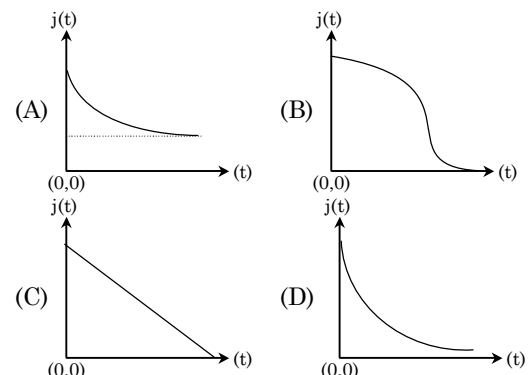

Q.29 An incandescent bulb has a thin filament of tungsten that is heated to high temperature by passing an electric current. The hot filament emits black-body radiation. The filament is observed to break up at random locations after a sufficiently long time of operation due to non-uniform evaporation of tungsten from the filament. If the bulb is powered at constant voltage, which of the following statement(s) is(are) true? **MCQ [JEE-Advance-2016]**

- (A) The temperature distribution over the filament is uniform
- (B) The resistance over small sections of the filament decreases with time
- (C) The filament emits more light at higher band of frequencies before it breaks up
- (D) The filament consumes less electrical power towards the end of the life of the bulb

Q.30 Consider two identical galvanometers and two identical resistors with resistance R . If the internal resistance of the galvanometers $R_C < R/2$, which of the following statement(s) about any one of the galvanometers is(are) true? **MCQ [JEE-Advance-2016]**

- (A) The maximum voltage range is obtained when all the components are connected in series
- (B) The maximum voltage range is obtained when the two resistors and one galvanometer are connected in series, and the second galvanometer is connected in parallel to the first galvanometer
- (C) The maximum current range is obtained when all the components are connected in parallel
- (D) The maximum current range is obtained when the two galvanometers are connected in series and the combination is connected in parallel with both the resistors

Q.31 In the circuit shown below, the key is pressed at time $t = 0$. Which of the following statement(s) is(are) true? **MCQ [JEE-Advance-2016]**

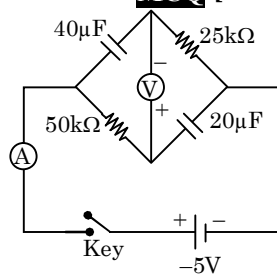

- (A) The voltmeter displays -5 V as soon as the key is pressed, and displays $+5$ V after a long time
- (B) The voltmeter will display 0 V at time $t = \ln 2$ seconds
- (C) The current in the ammeter becomes $1/e$ of the initial value after 1 second

(D) The current in the ammeter becomes zero after a long time

Passage Based Que. (Q.32 - 33)

Consider an evacuated cylindrical chamber of height h having rigid conducting plates at the ends and an insulating curved surface as shown in the figure.

A number of spherical balls made of a light weight and soft material and coated with a conducting material are placed on the bottom plate. The balls have a radius $r \ll h$. Now a high voltage source (HV) is connected across the conducting plates such that the bottom plate is at $+V_0$ and the top plate at $-V_0$. Due to their conducting surface, the balls will get charged, will become equipotential with the plate and are repelled by it. The balls will eventually collide with the top plate, where the coefficient of restitution can be taken to be zero due to the soft nature of the material of the balls. The electric field in the chamber can be considered to be that of a parallel plate capacitor. Assume that there are no collisions between the balls and the interaction between them is negligible. (Ignore gravity) **[JEE-Advance-2016]**

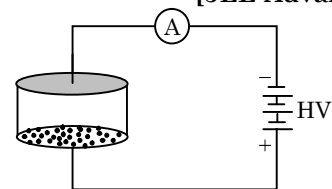

Q.32 Which one of the following statements is correct?

- (A) The balls will execute simple harmonic motion between the two plates
- (B) The balls will bounce back to the bottom plate carrying the same charge they went up with
- (C) The balls will stick to the top plate and remain there
- (D) The balls will bounce back to the bottom plate carrying the opposite charge they went up with

Q.33 The average current in the steady state registered by the ammeter in the circuit will be

- (A) proportional to V_0^2
- (B) proportional to the potential V_0
- (C) zero
- (D) proportional to $V_0^{1/2}$

Passage Based Que. (Q.34 - 35)

Consider a simple RC circuit as shown in Figure 1.

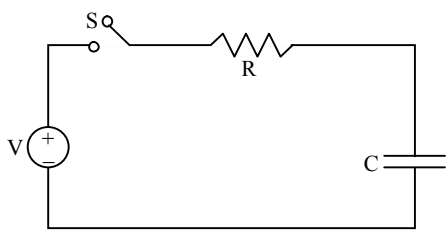

Figure 1

Process 1 : In the circuit the switch S is closed at $t = 0$ and the capacitor is fully charged to voltage V_0 (i.e., charging continues for time $T \gg RC$). In the process some dissipation (E_D) occurs across the resistance R. The amount of energy finally stored in the fully charged capacitor is E_C .

Process 2 : In a different process the voltage is first set to $\frac{V_0}{3}$ and maintained for a charging time $T \gg RC$. Then the voltage is raised to $\frac{2V_0}{3}$ without discharging the capacitor and again maintained for a time $T \gg RC$. The process is repeated one more time by raising the voltage to V_0 and the capacitor is charged to the same final voltage V_0 as in Process 1.

[JEE-Advance-2017]

These two processes are depicted in Figure 2.

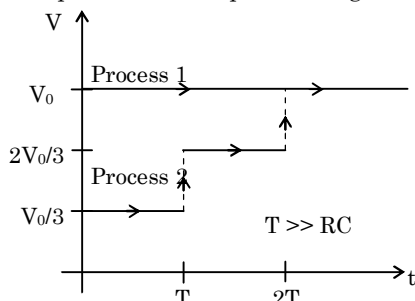

Figure 2

Q.34 In Process 1, the energy stored in the capacitor E_C and heat dissipated across resistance E_D are related by :

- (A) $E_C = E_D \ln 2$ (B) $E_C = \frac{1}{2} E_D$
 (C) $E_C = E_D$ (D) $E_C = 2E_D$

Q.35 In Process 2, total energy dissipated across the resistance E_D is :

- (A) $E_D = \frac{1}{3} \left(\frac{1}{2} CV_0^2 \right)$ (B) $E_D = 3 \left(\frac{1}{2} CV_0^2 \right)$
 (C) $E_D = \frac{1}{2} CV_0^2$ (D) $E_D = 3 CV_0^2$

Q.36 A moving coil galvanometer has 50 turns and each turn has an area $2 \times 10^{-4} m^2$. The magnetic field produced by the magnet inside the

galvanometer is $0.02 T$. The torsional constant of the suspension wire is $10^{-4} N m rad^{-1}$. When a current flows through the galvanometer, a full scale deflection occurs if the coil rotates by $0.2 rad$. The resistance of the coil of the galvanometer is 50Ω . This galvanometer is to be converted into an ammeter capable of measuring current in the range $0 - 1.0 A$. For this purpose, an shunt resistance is to be added in parallel to the galvanometer. The value of this shunt resistance, in ohms, is _____.

[JEE-Advanced-2018]

Q.37 In the circuit shown, initially there is no charge on capacitors and keys S_1 and S_2 are open. The values of the capacitors are $C_1 = 10 \mu F$, $C_2 = 30 \mu F$ and $C_3 = C_4 = 80 \mu F$.

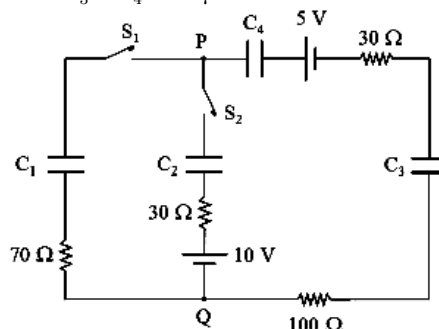

Which of the statement(s) is/are correct ?

[MCQ] [JEE-Advanced-2019]

- (A) At time $t = 0$, the key S_1 is closed, the instantaneous current in the closed circuit will be 25 mA
 (B) The key S_1 is kept closed for long time such that capacitors are fully charged. Now key S_2 is closed, at this time, the instantaneous current across 30Ω resistor (between points P and Q) will be 0.2 A (round off to 1st decimal place)
 (C) If key S_1 is kept closed for long time such that capacitors are fully charged, the voltage across the capacitor C_1 will be 4 V
 (D) If key S_1 is kept closed for long time such that capacitors are fully charged, the voltage difference between points P and Q will be 10 V

Q.38 Two identical moving coil galvanometers have 10Ω resistance and full scale deflection at $2 \mu A$ current. One of them is converted into a voltmeter of 100 mV full scale reading and the other into an Ammeter of 1 mA full scale current using appropriate resistors. These are then used to measure the voltage and current in the Ohm's law experiment with $R = 1000 \Omega$ resistor by using an ideal cell. Which of the following statement(s) is/are correct ?

[MCQ] [JEE-Advanced-2019]

- (A) The resistance of the Ammeter will be 0.02Ω (round off to 2nd decimal place)
- (B) The measured value of R will be $978 \Omega < R < 982 \Omega$
- (C) If the ideal cell is replaced by a cell having internal resistance of 5Ω then the measured value of R will be more than 1000Ω
- (D) The resistance of the Voltmeter will be $100 \text{ k}\Omega$

Q.39 Shown in figure is a semicircular metallic strip that has thickness t and resistivity ρ . Its inner radius is R_1 and outer radius is R_2 . If a voltage V_0 is applied between its two ends, a current I flows in it. In addition, it is observed that a transverse voltage ΔV develops between its inner and outer surface due to purely kinetic effects of moving electrons (ignore any role of the magnetic field due to the current). Then (figure is schematic and not drawn to scale)

[JEE Advanced 2020]

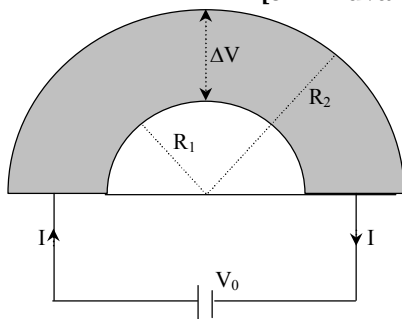

- (A) $I = \frac{V_0 t}{\pi \rho} \ln\left(\frac{R_2}{R_1}\right)$
- (B) the outer surface is at a higher voltage than the inner surface
- (C) the outer surface is at a lower voltage than the inner surface
- (D) $\Delta V \propto I^2$

Q.40 In the balanced condition, the values of the resistances of the four arms of a Wheatstone bridge are shown in the figure below. The resistance R_3 has temperature coefficient 0.0004 C^{-1} . If the temperature of R_3 is increased by 100°C , the voltage developed between S and T will be volt.

[JEE Advanced 2020]

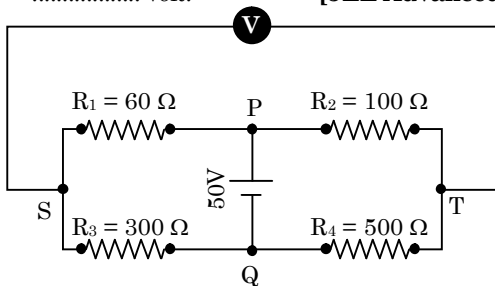

Question Stem for Question Nos.41 and 42

In the circuit shown below, the switch S is connected to position P for a long time so that the charge on the

capacitor becomes $q_1 \mu\text{C}$. Then S is switched to position Q . After a long time, the charge on the capacitor is $q_2 \mu\text{C}$.

[JEE Advanced 2021]

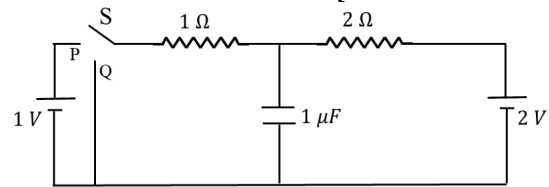

- Q.41** The magnitude of q_1 is ____.
- Q.42** The magnitude of q_2 is ____.
- Q.43** In order to measure the internal resistance r_1 of a cell of emf E , a meter bridge of wire resistance $R_0 = 50\Omega$, a resistance $R_0/2$, another cell of emf $E/2$ (internal resistance r) and a galvanometer G are used in a circuit, as shown in the figure. If the null point is found at $l = 72 \text{ cm}$, then the value of $r_1 = ______ \Omega$.

[JEE Advanced 2021]

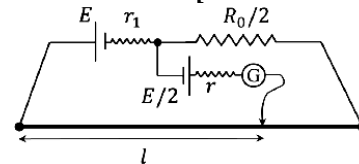

- Q.44** The figure shows a circuit having eight resistances of 1Ω each, labelled R_1 to R_8 , and two ideal batteries with voltages $\epsilon_1 = 12 \text{ V}$ and $\epsilon_2 = 6 \text{ V}$.

[MCQ] [JEE-Advanced-2022]

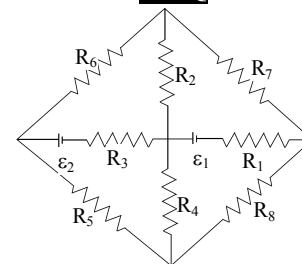

Which of the following statement(s) is(are) correct?

- (A) The magnitude of current flowing through R_1 is 7.2 A .
- (B) The magnitude of current flowing through R_2 is 1.2 A .
- (C) The magnitude of current flowing through R_3 is 4.8 A .
- (D) The magnitude of current flowing through R_5 is 2.4 A .
- Q.45** Two resistances $R_1 = X \Omega$ and $R_2 = 1 \Omega$ are connected to a wire AB of uniform resistivity, as shown in the figure. The radius of the wire varies linearly along its axis from 0.2 mm at A to 1 mm at B . A galvanometer (G) connected to the center of the wire, 50 cm from each end along its axis, shows zero deflection when A and B are connected to a battery. The value of x is ____.

[JEE Advanced 2022]

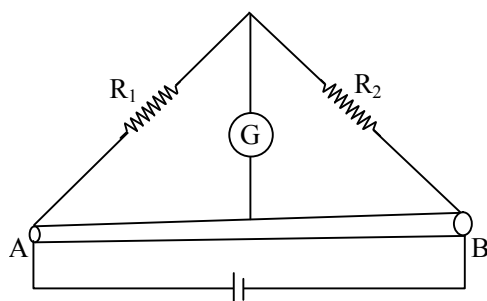

Q.46 In Circuit-1 and Circuit-2 shown in the figures, $R_1 = 1\Omega$, $R_2 = 2\Omega$ and $R_3 = 3\Omega$. P_1 and P_2 are the power dissipations in Circuit-1 and Circuit-2 when the switches S_1 and S_2 are in open conditions, respectively.

Q_1 and Q_2 are the power dissipations in Circuit-1 and Circuit-2 when the switches S_1 and S_2 are in closed conditions, respectively.

MCQ [JEE-Advanced-2022]

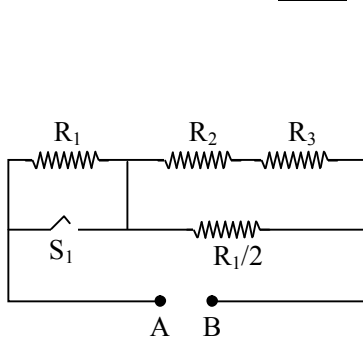

Circuit-1

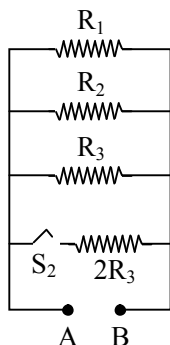

Circuit-2

Which of the following statements (s) is (are) correct ?

- (A) When a voltage source of 6V is connected across A and B in both circuits, $P_1 < P_2$
- (B) When a constant current source of 2 Amp is connected across A and B in both circuits, $P_1 > P_2$
- (C) When a voltage source of 6V is connected across A and B in Circuit-1, $Q_1 > P_1$.
- (D) When a constant current source of 2 Amp is connected across A and B in both circuits, $Q_2 < Q_1$.

Q.47 In a circuit shown in the figure, the capacitor C is initially uncharged and the key K is open. In this condition, a current of 1 A flows through the 1Ω resistor. The key is closed at time $t = t_0$. Which of the following statement(s) is(are) correct? [Given: $e^{-1} = 0.36$]

MCQ [JEE-Advanced-2023]

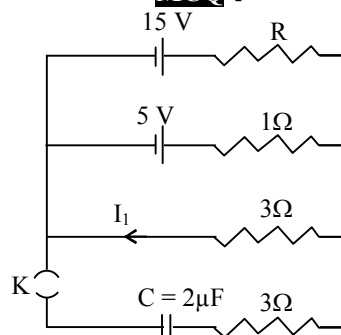

- (A) The value of the resistance R is 3Ω .
- (B) For $t < t_0$, the value of current I_1 is 2 A.
- (C) At $t = t_0 + 7.2\mu s$, the current in the capacitor is 0.6 A.
- (D) For $t \rightarrow \infty$, the charge on the capacitor is $12\mu C$.

EXERCISE (Level-6)

Review Exercise

- Q.1** Calculate the steady state current in the 2Ω resistor shown in the circuit (see figure). The internal resistance of the battery is negligible and the capacitance of the condenser C is $0.2\ \mu\text{F}$. [IIT-JEE 1982]

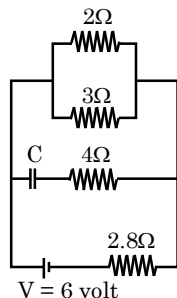

- Q.2** Two resistors, $400\ \Omega$, and $800\ \Omega$ are connected in series with a $6\ \text{V}$ battery. It is desired to measure the current in the circuit. An ammeter of $10\ \Omega$ resistance is used for this purpose. What will be the reading in the ammeter? Similarly, if a voltmeter of $1000\ \Omega$ resistance is used to measure the potential difference across the $400\ \Omega$ resistor, what will be the reading in the voltmeter? [IIT-JEE 1982]

- Q.3** A wire of length L and 3 identical cells of negligible internal resistances are connected in series. Due to the current the temperature of the wire is raised by ΔT in a time t . A number N of similar cells is now connected in series with a wire of the same material and cross-section but of length $2L$. The temperature of the wire is raised by the same amount ΔT in the same time t . The value of N is - [IIT-JEE 2001]
(A) 4 (B) 6 (C) 8 (D) 9

- Q.4** A piece of copper and another of germanium are cooled from room temperature to 80K . The resistance of - [IIT-JEE 1988]
(A) Each of them increases
(B) Each of them decreases
(C) Copper increases and germanium decreases
(D) Copper decreases and germanium increases

- Q.5** In the given circuit -
 $E_1 = 3$, $E_2 = 2$, $E_3 = 6$ volt,
 $R_1 = 2\Omega$, $R_4 = 6$ ohm, $R_3 = 2\Omega$,
 $R_2 = 4$ ohm, $C = 5\ \mu\text{F}$.
Find the current in R_3 and the energy stored in the capacitor. [IIT-JEE 1998]

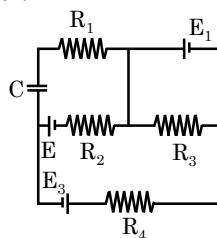

- Q.6** A micro ammeter has a resistance of $100\ \Omega$ and full scale range of $50\ \mu\text{A}$. It can be used as a voltmeter or as a higher range ammeter provided a resistance is added to it. Pick the correct range and resistance combinations - [MCQ] [IIT-JEE 1991]

- (A) $50\ \text{V}$ range with $10\ \text{K}\Omega$ resistance in series
(B) $10\ \text{V}$ range with $200\ \text{K}\Omega$ resistance in series
(C) $5\ \text{mA}$ range with $1\ \Omega$ resistance in parallel
(D) $10\ \text{mA}$ range with $1\ \Omega$ resistance in parallel

- Q.7** Read the following statements carefully -
Y : The resistivity of semiconductor decreases with increases of temperature.

Z : In a conducting solid, the rate of collisions between free electrons and ions increases with increase of temperature.

Select the correct statement (s) from the following [IIT-JEE 1993]

- (A) Y is true but Z is false
(B) Y is false but Z is true
(C) Both Y and Z are true
(D) Y is true and Z is the correct reason for Y

- Q.8** A battery of internal resistance $4\ \Omega$ is connected to the network of resistance as shown. In order that maximum power can be delivered to the network, the value of R in ohm should be - [IIT-JEE 1995]

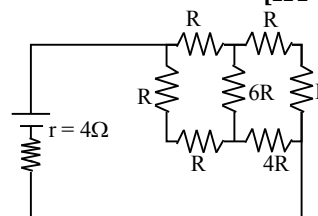

- (A) $\frac{4}{9}$ (B) 2 (C) $\frac{8}{3}$ (D) 18

- Q.9** A uniform copper wire of mass $2.23 \times 10^{-3}\ \text{kg}$ carries a current of $1\ \text{A}$ when $1.7\ \text{V}$ is applied across it. Calculate its length and area of cross-section. If the wire is uniformly stretched to double its length, calculate the new resistance. Density of copper is $8.92 \times 10^3\ \text{kg m}^{-3}$ and resistivity is $1.7 \times 10^{-8}\ \Omega\text{m}$. [Roorkee 95]

- Q.10** An electrical circuit is shown in figure. Calculate the potential difference across the resistor of $400\ \text{ohm}$, as will be measured by the voltmeter V of resistance $400\ \text{ohm}$, either by applying Kirchhoff's rules or otherwise. [IIT-JEE 1996]

- Q.11** In the circuit shown in Fig., the battery is an ideal one, with emf V . The capacitor is initially uncharged. The switch S is closed at time $t = 0$.
(a) Find the charge Q on the capacitor at time t .
(b) Find the current in AB at time t . What is its limiting value at $t \rightarrow \infty$?

[IIT-JEE 1997]

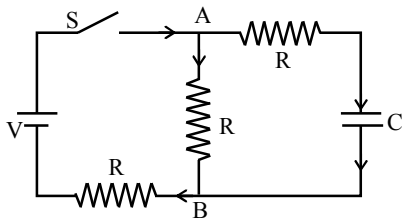

- Q.12** A steady current flows in a metallic conductor of non-uniform cross section. The quantity/quantities constant along the length of the conductor is –
[IIT-JEE 1997]
 (A) current, electric field and drift speed
 (B) drift speed only
 (C) current and drift speed
 (D) current only

- Q.13** A series combination of $0.1 \text{ M } \Omega$ resistor and a $10 \mu\text{F}$ capacitor is connected across a 1.5 V source of negligible resistance. The time required for the capacitor to get charged up to 0.75 V is approximately (in seconds)
[IIT-JEE 1997]
 (A) ∞ (B) $\log_e 2$ (C) $\log_{10} 2$ (D) Zero

- Q.14** A thin uniform wire AB of length 1 m , an unknown resistance X and a resistance of 12Ω are connected by thick conducting strips, as shown in the figure. A battery and a galvanometer (with a sliding jockey connected to it) are also available. Connections are to be made to measure the unknown resistance X using the principle of Wheatstone bridge. Answer the following questions.
 (a) Are there positive and negative terminals on the galvanometer?
 (b) Copy the figure in your answer book and show the battery and the galvanometer (with jockey) connected at appropriate points.
 (c) After appropriate connections are made, it is found that no deflection takes place in the galvanometer when the sliding jockey touches the wire at a distance of 60 cm from A. Obtain the value of the resistance X .
[IIT-JEE 2002]

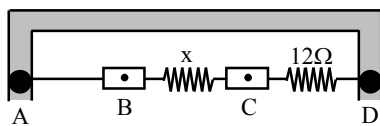

- Q.15** As shown in the figure a battery is to be connected so that the rheostat behaves like potential divider. Indicate how the battery should be connected. Also indicate the points about which output can be taken.
[IIT-JEE 2003]

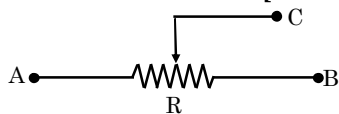

- Q.16** In the circuit shown in figure, the current through –
[IIT-JEE 1998]

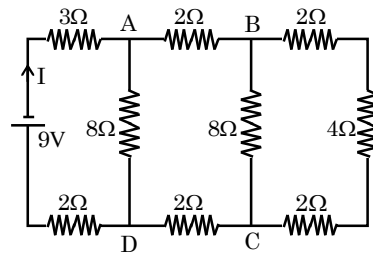

- (A) the 3Ω resistor is 0.50 A
 (B) the 3Ω resistor is 0.25 A
 (C) the 4Ω resistor is 0.50 A
 (D) the 4Ω resistor is 0.25 A
- Q.17** In the circuit $P \neq R$, the reading of the galvanometer is same with switch S open or closed. Then –
[IIT-JEE 1999]

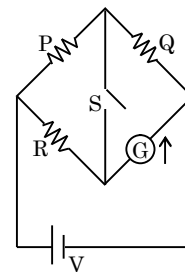

- (A) $I_R = I_G$ (B) $I_P = I_G$ (C) $I_Q = I_G$ (D) $I_Q = I_R$
- Q.18** Draw the circuit diagram to verify Ohm's Law with the help of a main resistance of 100Ω and two galvanometers of resistances $10^6 \Omega$ and $10^{-3} \Omega$ and a source of varying emf. Show the correct positions of voltmeter and ammeter.
[IIT-JEE 2004]

- Q.19** A parallel plate capacitor is charged to a potential difference of 50 V . It is discharged through a resistance. After 1 second , the potential difference between plates becomes 40 V . Then –
[MCQ] [REE-99]

- (A) fraction of stored energy after 1 second is $16/25$
 (B) potential difference between the plates after 2 second will be 32 V
 (C) potential difference between the plates after 2 seconds will be 20 V
 (D) fraction of stored energy after 1 second is $4/5$

- Q.20** A homogeneous proton beam accelerated by a potential difference $V = 600 \text{ kV}$ has a round cross-section of radius $r = 5.0 \text{ mm}$. Find the electric field strength on the surface of the beam and the potential difference between the surface and the axis of the beam, if the beam current is equal to $I = 50 \text{ mA}$.

Q.21 The air between two closely located plates is uniformly ionized by uv radiation. The air volume between the plates is equal to $V = 500 \text{ cm}^3$, the observed saturation current is equal to $I_{\text{sat}} = 0.48 \text{ }\mu\text{A}$. Find :

- the number of ion pairs produced in a unit volume per unit time,
- the equilibrium concentration of ion pairs if the recombination coefficient for air ions is equal to $r = 1.67 \times 10^{-6} \text{ cm}^3/\text{s}$.

Q.22 A semicircular ring of Cu has an inner radius of 8 cm, radial thickness 4 cm and axial thickness 6 cm. Calculate the resistance of the ring at 50°C between its two end faces. Resistivity of Cu at $20^\circ\text{C} = 1.724 \times 10^{-6} \text{ }\Omega\text{-cm}$. Resistance temperature coefficient of Cu at $0^\circ\text{C} = 0.0043/\text{C}$.

Q.23 (A) It is desired to make a long cylindrical conductor whose temperature coefficient of resistivity at 20°C will be close to zero.

- If such a conductor is made by assembling alternate disks of iron and carbon, what is the ratio of the thickness of a carbon disk to that of an iron disk ? Assume that the temp. remains essentially the same in each disk.

- What is the ratio of the rate of Joule heating in a carbon disk to that in an iron disk?

Calculate the expression in terms of α_c , α_{fe} , ρ_c & ρ_{fe} . Where α_c & α_{fe} are temperature coefficient of resistance of carbon & iron and ρ_c & ρ_{fe} are resistivity of carbon & iron at temp 20°C .

(B) A silver wire of length 10 m and cross-section 10^{-8} m^2 is suspended vertically and a weight of 10 N is attached to it. Calculate the percentage increase in its resistance (after attach the weight with it), given that Young's Modulus for silver is $7 \times 10^{10} \text{ Nm}^{-2}$, and the resistivity of silver of silver remains constant during the stretching process.

Q.24 A wire frame in the form of a tetrahedron ABCD is connected to a dc source (Fig.). The resistances of all the edges of the tetrahedron are equal. Indicate the edge of the frame that should be eliminated to obtain the maximum change in the current ΔI_{max} in the circuit, neglecting the resistance of the leads.

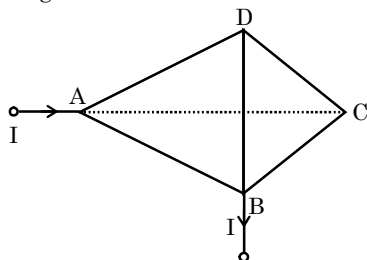

Q.25 Figure shows a conductor of length l having a circular cross-section. The radius of cross-section varies linearly from a to b . The resistivity of the material is ρ . Assuming that $b - a \ll l$, find the resistance of the conductor.

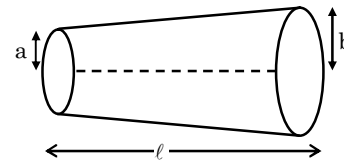

Q.26 The space between two conducting concentric spheres of radii a and b ($a < b$) is filled up with homogeneous poorly conducting medium. The capacitance of such a system equals C . Find the resistivity of the medium if the potential difference between the spheres when they are disconnected from an external voltage, decreases η -fold during the time interval Δt .

Q.27 A network of resistance is constructed with R_1 & R_2 as shown in the figure. The potential at the points 1, 2, 3, ... N are $V_1, V_2, V_3, \dots, V_N$ respectively each having a potential k time smaller than previous one. Find-

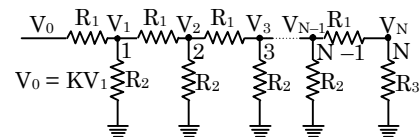

- $\frac{R_1}{R_2}$ and $\frac{R_2}{R_3}$ in terms of k
- Current that passes through the resistance R_2 nearest to the V_0 in terms V_0, k & R_3

Q.28 In the figure 1 metre length wire PQ is a wire of uniform cross-section and of resistance R_0 . A is an ideal ammeter and the cells are of negligible resistance. The jockey J can freely slide over the wire PQ making contact on it at S. If the length of the wire PS is $f = 1/n^{\text{th}}$ of PQ, find the reading on the ammeter. Find the value of 'f' for maximum and minimum reading on the ammeter.

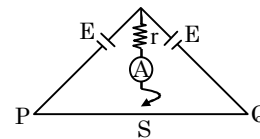

Q.29 Current density in a cylindrical wire of radius

$$R \text{ is given as } J = \begin{cases} J_0 \left(\frac{x}{R} - 1 \right) & \text{for } 0 \leq x < \frac{R}{2} \\ J_0 \frac{x}{R} & \text{for } \frac{R}{2} \leq x \leq R \end{cases}$$

Find the current flowing in the wire.

- Q.30** A frame made of thin homogeneous wire is shown in figure. Assume that the number of successively embedded equilateral triangle with sides decreasing by half tends to infinity. The side AB has a resistance R_0 . Find the equivalent resistance between A and B.

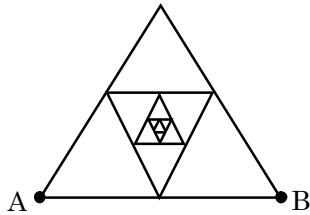

- Q.31** A conductor is made of an isotropic material (resistivity ρ) has rectangular cross-section. Horizontally dimension of the rectangle decreases linearly from $2x$ at one end to x at the other end and vertical dimension increases from y to $2y$ as shown in figure. Length of the conductor along the axis is equal to ℓ . A battery is connected across this conductor then - **MCQ**

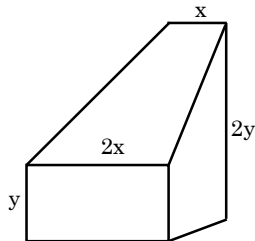

- (A) rate of generation of heat per unit length is maximum at the ends of conductor
 (B) rate of generation of heat per unit length is maximum at middle cross-section
 (C) drift velocity of conduction electrons is minimum at middle section
 (D) at the ends of the conductor, electric field intensity is same

- Q.32** In the given post office box. Unknown resistance should be connected - **[IIT-JEE 2004]**

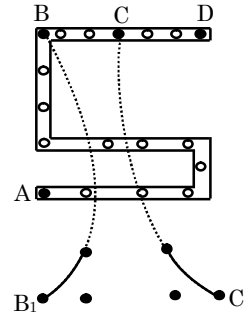

- (A) Between A & D (B) Between A & C
 (C) Between C & D (D) Between B₁ & C₁

ANSWER KEY

EXERCISE (Level-1)

- | | | | | | | | | | |
|---------|---------|---------|---------|---------|---------|---------|---------|---------|---------|
| 1. (B) | 2. (C) | 3. (A) | 4. (B) | 5. (B) | 6. (C) | 7. (C) | 8. (C) | 9. (B) | 10. (D) |
| 11. (B) | 12. (B) | 13. (C) | 14. (A) | 15. (A) | 16. (C) | 17. (C) | 18. (D) | 19. (B) | 20. (A) |
| 21. (A) | 22. (B) | 23. (C) | 24. (A) | 25. (B) | 26. (B) | 27. (B) | 28. (B) | 29. (B) | 30. (B) |
| 31. (C) | 32. (D) | 33. (B) | 34. (A) | 35. (C) | 36. (B) | 37. (B) | 38. (C) | 39. (B) | 40. (D) |
| 41. (C) | 42. (C) | | | | | | | | |

EXERCISE (Level-2)

- | | | | | | | | | | |
|---------|---------|---------|---------|---------|---------|---------|---------|---------|---------|
| 1. (B) | 2. (B) | 3. (B) | 4. (D) | 5. (C) | 6. (D) | 7. (D) | 8. (A) | 9. (B) | 10. (B) |
| 11. (A) | 12. (B) | 13. (C) | 14. (C) | 15. (C) | 16. (A) | 17. (B) | 18. (D) | 19. (C) | 20. (B) |
| 21. (B) | 22. (D) | 23. (B) | 24. (A) | 25. (B) | 26. (A) | 27. (C) | 28. (B) | 29. (B) | 30. (B) |
| 31. (C) | 32. (C) | 33. (A) | 34. (D) | 35. (A) | 36. (B) | 37. (D) | 38. (C) | 39. (D) | 40. (C) |
| 41. (D) | 42. (C) | 43. (D) | 44. (B) | | | | | | |

EXERCISE (Level-3)

- | | | | | | | | | | |
|------------|----------|----------|----------|------------|------------|-----------|-----------|-------------------|-------------|
| 1. (D) | 2. (B) | 3. (B) | 4. (B) | 5. (D) | 6. (B) | 7. (B) | 8. (D) | 9. (D) | 10. (A) |
| 11. (C) | 12. (B) | 13. (B) | 14. (B) | 15. (A) | 16. (D) | 17. (B) | 18. (B) | 19. (B) | 20. (B) |
| 21. (B) | 22. (C) | 23. (D) | 24. (C) | 25. (B) | 26. (B) | 27. (C) | 28. (B) | 29. (C) | 30. (B) |
| 31. (D) | 32. (C) | 33. (B) | 34. (C) | 35. (B) | 36. (C) | 37. (D) | 38. (A) | 39. (C) | 40. (A) |
| 41. (B) | 42. (B) | 43. (C) | 44. (A) | 45. (B) | 46. (A) | 47. (C) | 48. (C) | 49. (B) | 50. (A) |
| 51. (D) | 52. (A) | 53. (B) | 54. (D) | 55. (D) | 56. (B) | 57. (D) | 58. (C) | 59. (B) | 60. (A) |
| 61. (B) | 62. (A) | 63. (B) | 64. (A) | 65. (A) | 66. (A) | 67. (A) | 68. (C) | 69. (D) | 70. (C) |
| 71. (D) | 72. (D) | 73. (B) | 74. (B) | 75. (A) | 76. (D) | 77. (D) | 78. (B) | 79. (D) | 80. (B) |
| 81. (C) | 82. (D) | 83. (A) | 84. (C) | 85. (B) | 86. (A) | 87. (C) | 88. (B) | 89. (Drop by NTA) | 90. (A) |
| 91. (B) | 92. (B) | 93. (D) | 94. (D) | 95. (C) | 96. (D) | 97. (D) | 98. (A) | 99. (B) | 100. (B) |
| 101. (A) | 102. (A) | 103. (C) | 104. 1 | 105. (D) | 106. 12.00 | 107. 3.00 | 108. 8.00 | 109. 4.00 | 110. 780.00 |
| 111. 14.00 | 112. (B) | 113. (C) | 114. (C) | 115. 01.50 | 116. (A) | 117. 36 | 118. (A) | 119. (A) | 120. (A) |
| 121. 81 | 122. (D) | | | | | | | | |

EXERCISE (Level-4)

Part-A

- | | | | | | | |
|--------------|----------|-------------|-----------|----------|-----------|---------------|
| 1. (A,B,C,D) | 2. (A,C) | 3. (A,B,D) | 4. (C,D) | 5. (A,D) | 6. (C,D) | 7. (A,D) |
| 8. (A,D) | 9. (A,C) | 10. (A,B,C) | 11. (A) | 12. (C) | 13. (A,C) | 14. (A,B,C,D) |
| 15. (B,C,D) | 16. (C) | 17. (B,D) | 18. (A,D) | | | |

Part-B

- | | | | | | | | |
|---------|---------|---------|---------|---------|---------|---------|---------|
| 19. (A) | 20. (B) | 21. (A) | 22. (A) | 23. (A) | 24. (C) | 25. (A) | 26. (A) |
|---------|---------|---------|---------|---------|---------|---------|---------|

Part-C

27. $A \rightarrow Q$; $B \rightarrow P, Q, R$; $C \rightarrow Q$; $D \rightarrow P, Q, R, S$

28. $A \rightarrow Q$; $B \rightarrow R$; $C \rightarrow S$; $D \rightarrow P$

29. $A \rightarrow R$; $B \rightarrow P, Q, R, S$; $C \rightarrow S$; $D \rightarrow S$

Part-D

30. (D) 31. (B) 32. (D) 33. (C) 34. (A) 35. (A) 36. (D) 37. (A) 38. (D) 39. (B)
 40. (C) 41. (C) 42. (C) 43. (D)

Part-E

44. [(a) $32\ \Omega$ (b) $20\ \text{V}$ (c) $20\ \text{V}$] 45. 2 46. [(a) (i) $I = \alpha$, (ii) $\phi_A - \phi_B = 0$, (b) (i) $0.3\ \text{A}$ (ii) $3\ \text{A}$]
 47. [(a) $6\ \text{V}$ and $-4\ \text{V}$, (b) 90%] 48. [(A) $7\ \text{paise}$, (b) $9\ \text{paise}$] 49. 8
 50. [160 cells, mixed grouping \Rightarrow 4 rows and each row will contain 40 cells]
 51. (a) $\left[\frac{V^2}{KR} (1 - e^{-Kt/C}) \right]$ (b) $\frac{a}{\lambda} i^2 R$ 52. One 53. 2 54. 8
 55. $EC \left(1 - \frac{1}{e} \right) + \frac{VC}{e^2}$ 56. 2 57. 4 58. 3
 59. 1 60. 3 61. (a) $6\ \text{m}$ (b) $1\ \Omega$
 62. (a) $1.25\ \text{V}$
 (b) The high resistance is kept to keep the initial current low when the null point is being located. This saves the standard cell from damage.
 (c) This high resistance does not affect the balance point because then there is no flow of current through the standard cell branch.
 (d) The internal resistance of the driver cell affects the current through the potentiometer wire. Since the potential gradient is changed, therefore, the balance point must be affected.
 (e) No, it is necessary that the emf of the driver cell is more than the emf of the cells.
 63. $50\ \Omega$ or $25\ \Omega$ 64. $Q^2 \pi^2 R / 8T$

EXERCISE (Level-5)

1. $Q_0 = \frac{CVR_2}{R_1 + R_2}$ and $\alpha = \frac{R_1 + R_2}{R_1 R_2 C}$ 2. The null point at B will give the most accurate reading
 3. (A) 4. (A) 5. (B) 6. (A) 7. (A) 8. (A) 9. (C)
 10. (D) 11. (A) 12. $A \rightarrow P, Q, S, T; B \rightarrow Q; C \rightarrow S; D \rightarrow S$ 13. (A) 14. (C)
 15. (D) 16. (C) 17. 4 18. 2 19. (B) 20. $5\ \text{volt}$ 21. (A, B, C, D)
 22. (A, B, D) 23. (C, D) 24. 5 25. (B, D) 26. (B) 27. 1 28. (D)
 29. (D) 30. (A, C) 31. (A, B, C, D) 32. (D) 33. (A) 34. (C) 35. (A)
 36. 5.55 37. (A, C) 38. (A, B) 39. (A, C, D) 40. 0.26 41. $1.33\ \mu\text{C}$ 42. $0.67\ \mu\text{C}$
 43. 3 44. (A, B, C, D) 45. 5 46. (A, B, C) 47. (A, B, C, D)

EXERCISE (Level-6)

1. $0.9\ \text{A}$ 2. $4.96\ \text{mA}$, $1.58\ \text{volt}$ 3. (B) 4. (D)
 5. $1.5\ \text{A}$ from right to left and energy stored is $1.44 \times 10^{-5}\ \text{J}$ 6. (B, C) 7. (C) 8. (B)
 9. $\ell = 5\ \text{m}$, $A = 5 \times 10^{-8}$, $R_1 = 4\ \Omega$, $R = 6.8\ \Omega$ 10. p.d. = $\frac{20}{3}\ \text{V}$
 11. (a) $Q = \frac{VC}{2} \left(1 - e^{-2t/3RC} \right)$ (b) $I_1 = \frac{V}{2R} - \frac{Ve^{-2t/3RC}}{6R}$, $\lim_{t \rightarrow \infty} I_1 = \frac{V}{2R}$ 12. (D) 13. (B)

14. (a) Galvanometer has no positive or negative terminals ; (c) 8Ω
15. Output terminals are [A, C] or [B, C] 16. (D) 17. (A) 19. (A, B)
20. [$E = 32\text{V/m}$, $\Delta\phi = 0.8\text{ V}$]
21. [(a) $6 \times 10^9\text{ cm}^{-3}\text{ s}^{-1}$ (b) $6 \times 10^7\text{ cm}^3$]
22. [(a) 84.5°C (b) $2.5 \times 10^{-6}\Omega$]
23. [(a) $\frac{t_c}{t_{fe}} = \frac{-\rho_{fe}}{\rho_C} \times \frac{\alpha_{fe}}{\alpha_c}$, (b) $\frac{H_c}{H_{fe}} = \frac{\alpha_{fe}}{\alpha_C}$, (B) 20/7]
24. [Edge AB] 25. $\frac{\rho I}{\pi ab}$ 26. [$\rho = 4\pi ab\Delta t / (b - a)$ (C In η)]
27. (i) $\frac{(K-1)^2}{K}$; $\frac{K}{K-1}$ (ii) $\frac{((K-1)/K^2)v_0}{R_3}$ 28. $\frac{\varepsilon}{r + R_0(f - f^2)}$; for $I_{\max} f = 0, 1$; $I_{\min} f = 1/2$
29. $\frac{5}{12} \pi J_0 R^2$ 30. $X = \left(\frac{\sqrt{7} - 1}{3} \right) R_0$ 31. (A, C, D) 32. (A)